

- ▷ Quick Change Tapping Chucks ▷ 快換式絲攻刀桿
- ▷ With Length Compensation/Extra Length ▷ 伸縮緩衝加長型

Features:

- Quick Change of Tap Adapters.
- Length Compensation could prevent tap from breaking upon tapping.

特性:

- 快換式絲攻連接桿
- 緩衝可預防絲攻在攻牙時斷落

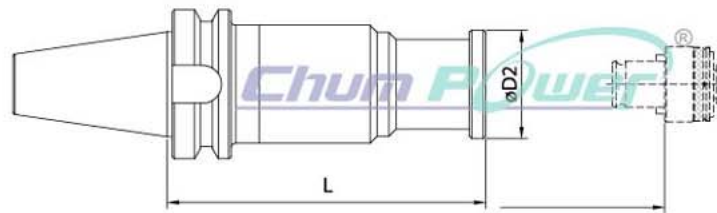

Code NO. 型號	SPEC. 規格	Capacity 攻牙能力	L	øD2	Collets 適用筒夾
36267	BT40-WFE12-135	M3~M12	135	38	TC312 TC312B
36268	BT40-WFE12-165	M3~M12	165	38	TC312 TC312B
36277	BT50-WFE12-135	M3~M12	135	38	TC312 TC312B
36279	BT50-WFE12-165	M3~M12	165	38	TC312 TC312B
36278	BT50-WFE12-195	M3~M12	195	38	TC312 TC312B

*Custom-Built products are available on request. *特製品可依客戶需求訂製

*Tap collets to be ordered separately. *絲攻夾頭需另購

- ▷ Quick Change Tapping Chucks
- ▷ With Length Compensation

Features:

- Quick Change of Tap Adapters.
- Length Compensation could prevent tap from breaking upon tapping.

- ▷ 快換式絲攻刀桿
- ▷ 伸縮緩衝型

特性:

- 快換式絲攻連接桿
- 緩衝可預防絲攻在攻牙時斷落

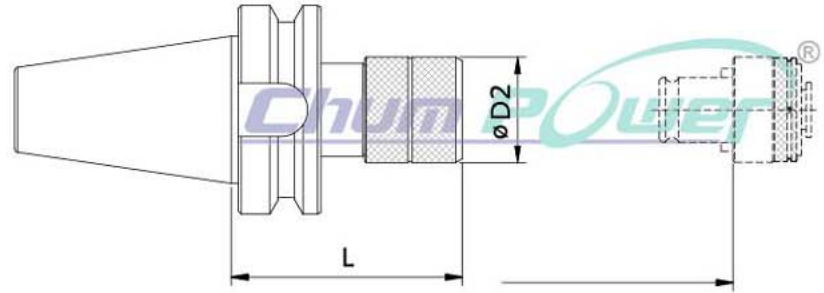

Code NO. 型號	SPEC. 規格	Capacity 攻牙能力	L	øD2	Collets 適用筒夾
36276	BT30-WF12	M3~M12	70	36	TC312 TC312B
36266	BT40-WF12	M3~M12	75	36	TC312 TC312B
36280	BT50-WF12	M3~M12	85	36	TC312 TC312B
36180	BT30-WF20	M8~M20	105	53	TC820 TC820B
36166	BT40-WF20	M8~M20	95	53	TC820 TC820B
36176	BT50-WF20	M8~M20	105	53	TC820 TC820B
36367	BT40-WF33	M14~M33	160	78	TC1433 TC1433B
36376	BT50-WF33	M14~M33	150	78	TC1433 TC1433B

*Custom-Built products are available on request. *特製品可依客戶需求訂製
 *Tap collets to be ordered separately. *絲攻夾頭需另購

- ▷ Quick Change Tapping Chucks
- ▷ With Length Compensation
- ▷ Straight Shank-Collets

- ▷ 快換式絲攻刀桿
- ▷ 伸縮緩衝型
- ▷ 直柄型-筒夾專用

Features:

- Quick Change of Tap Adapters.
- Length Compensation could prevent tap from breaking upon tapping.

特性:

- 快換式絲攻連接桿
- 緩衝可預防絲攻在攻牙時斷落

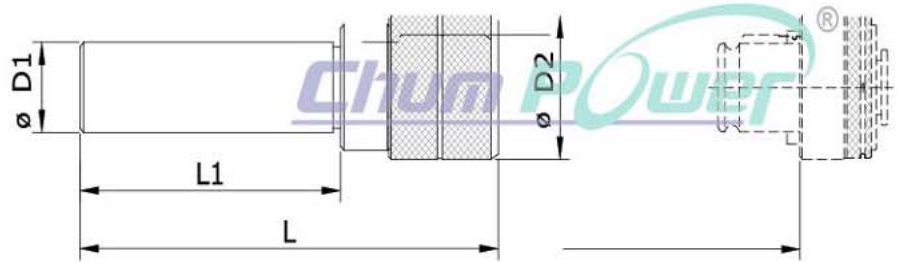

Code NO. 型號	SPEC. 規格	Capacity 攻牙能力	L	L1	øD1	øD2	Collets 適用筒夾
36261	D20-WF12	M3~M12	113	70	20	36	TC312
36271	D32-WF12	M3~M12	113	70	32	36	TC312B
36161	D20-WF20	M8~M20	135	70	20	53	TC820
36171	D32-WF20	M8~M20	135	70	32	53	TC820B
36371	D32-WF33	M14~M33	183	80	32	78	TC1433B

*Custom-Built products are available on request. *特製品可依客戶需求訂製
*Tap collets to be ordered separately. *絲攻夾頭需另購



- ⊕ Quick Change Tapping Chucks
- ⊕ With Length Compensation

Features:

- Quick Change of Tap Adapters.
- Length Compensation could prevent tap from breaking upon tapping.

- ⊕ 快換式絲攻刀桿
- ⊕ 伸縮緩衝型

特性：

- 快換式絲攻連接桿
- 緩衝可預防絲攻在攻牙時斷落

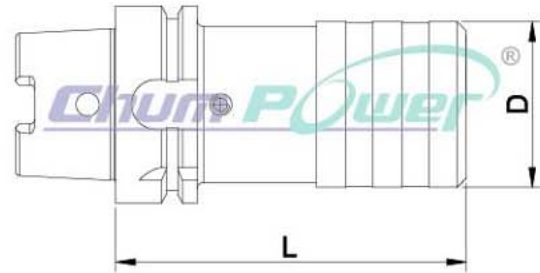

Code NO. 型號	Type 規格	Capacity 攻牙能力	L	D	Collets 適用筒夾
36269	HSK40A-WF12	M3-M12	95	36	TC312/B
36290	HSK50A-WF12	M3-M12	100	36	TC312/B
36169	HSK50A-WF20	M8-M20	140	53	TC820/B
36286	HSK63A-WF12	M3-M12	100	36	TC312/B
36186	HSK63A-WF20	M8-M20	145	53	TC820/B
36394	HSK63A-WF33	M14-M33	180	78	TC1433/B
36287	HSK100A-WF12	M3-M12	110	36	TC312/B
36187	HSK100A-WF20	M8-M20	150	53	TC820/B
36395	HSK100A-WF33	M14-M33	190	78	TC1433/B

*Custom-Built products are available on request. *特製品可依客戶需求訂製
*Tap collets to be ordered separately. *絲攻夾頭需另購



- ▷ Quick Change Tapping Chucks
- ▷ With Length Compensation

Features:

- Quick Change of Tap Adapters.
- Length Compensation could prevent tap from breaking upon tapping.

- ▷ 快換式絲攻刀桿
- ▷ 伸縮緩衝型

特性:

- 快換式絲攻連接桿
- 緩衝可預防絲攻在攻牙時斷落

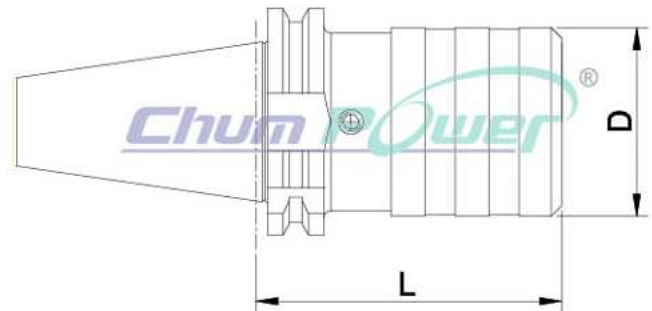

Code NO. 型號	Type 規格	Capacity 攻牙能力	L	D	Collets 適用筒夾
36251	SK30-WF12	M3-M12	70	36	TC312/B
36151	SK30-WF20	M8-M20	105	53	TC820/B
6281	SK40-WF12	M3-M12	75	36	TC312/B
6181	SK40-WF20	M8-M20	95	53	TC820/B
36360	SK40-WF33	M14-M33	160	78	TC1433/B
36275	SK50-WF12	M3-M12	85	36	TC312/B
36175	SK50-WF20	M8-M20	105	53	TC820/B
36385	SK50-WF33	M14-M33	150	78	TC1433/B

*Custom-Built products are available on request. *特製品可依客戶需求訂製
 *Tap collets to be ordered separately. *絲攻夾頭需另購



- ⊙ Quick Change Tapping Chucks
- ⊙ With Length Compensation
- ⊙ Straight Shank-Side-Lock&CNC Lathe

Features:

- Quick Change of Tap Adapters.
- Length Compensation could prevent tap from breaking upon tapping.

- ⊙ 快換式絲攻刀桿
- ⊙ 伸縮緩衝型
- ⊙ 直柄型-側固及CNC車床專用

特性:

- 快換式絲攻連接桿
- 緩衝可預防絲攻在攻牙時斷落

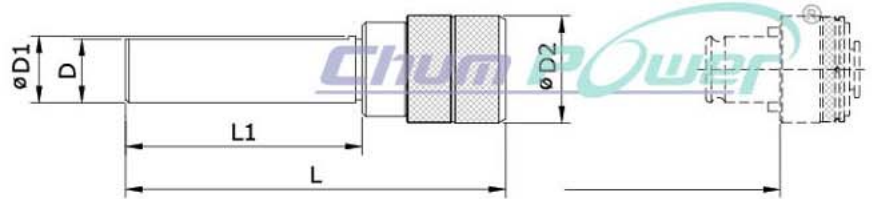

Code NO. 型號	SPEC. 規格	Capacity 攻牙能力	L	L1	D	øD1	øD2	Collets 適用筒夾
36262	D20A-WF12	M3~M12	113	70	19	20	36	TC312
36272	D32A-WF12	M3~M12	113	70	31	32	36	TC312B
36162	D20A-WF20	M8~M20	135	70	19	20	53	TC820
36172	D32A-WF20	M8~M20	135	70	31	32	53	TC820B
36372	D32A-WF33	M14~M33	183	80	31	32	78	TC1433B

*Custom-Built products are available on request. *特製品可依客戶需求訂製
 *Tap collets to be ordered separately. *絲攻夾頭需另購



- Ⓞ Quick Change Tapping Chucks
- Ⓞ With Length Compensation
- Ⓞ Morse Taper Shank

- Ⓞ 快換式絲攻刀桿
- Ⓞ 伸縮緩衝型
- Ⓞ 莫氏錐度型

Application:

The products are suitable for Radial Drilling Machines, CNC Turning Centers, High-Speed Center Lathes, Drilling Machines, Radial Drilling Machines, Air Tapping Machines, Milling Machines and other machines with reversible spindles.

用途:

此產品適用於旋臂式鑽床, 高速車床, 直立式鑽床, 銑床及其它可反轉的主軸。

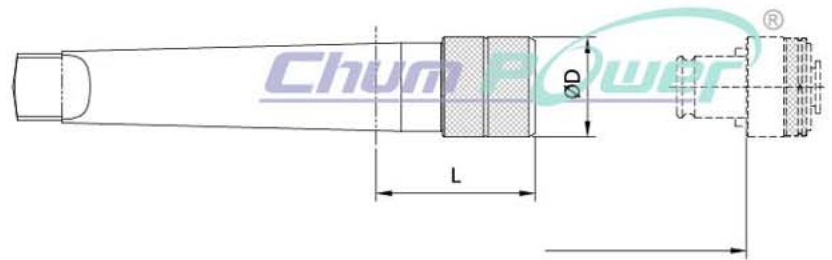

Code NO. 型號	SPEC. 規格	Capacity 攻牙能力	L	øD	Collets 適用筒夾
36263	MT2-WF12	M3~M12	475	36	TC312 TC312B
36264	MT3-WF12	M3~M12	475	36	
36265	MT4-WF12	M3~M12	49	36	
36163	MT2-WF20	M8~M20	70	53	TC820 TC820B
36164	MT3-WF20	M8~M20	70	53	
36165	MT4-WF20	M8~M20	70	53	
36365	MT4-WF33	M14~M33	110	78	TC1433 TC1433B

*Custom-Built products are available on request. *特製品可依客戶需求訂製
*Tap collets to be ordered separately. *絲攻夾頭需另購

Quick Change Tapping Chuck Adapter

Features:

- Specially designed for tapping machine.
- Can connect to tap collet.
- Can easily quick change to the tap

Application:

The products are suitable for Vertical Tapping Machines, Radial Drilling Machines, Vertical Drilling Machines, Milling Machines and other machines with reversible spindles and Power Tools and Air Tools.

快換式連接桿

特性:

- 攻牙機台專用
- 可連接絲攻筒夾
- 可快速轉換絲攻

用途:

此產品適用於直立式攻牙機, 旋臂式鑽床, 直立式鑽床, 銑床及其它可反轉的主軸及電鑽工具, 氣動工具。

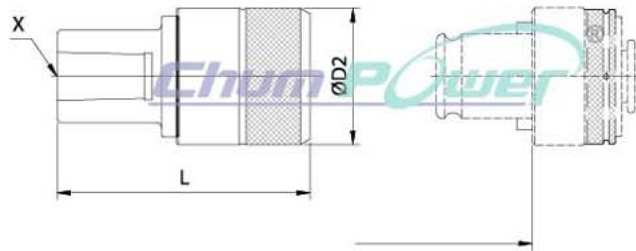

Code NO. 型號	SPEC. 規格	Capacity 攻牙能力	L	ØD2	X	Collets 適用筒夾
36206	JT6-SF12	M 3~M12	66	32	JT6	TC312 TC312B
36207	B16-SF12	M 3~M12	66	32	B16	
36208	JT2S-SF12	M 3~M12	61	32	JT2S	
36209	B12-SF12	M 3~M12	61	32	B12	TC820 TC820B
36106	JT6-SF20	M 8~M24	86	50	JT6	
36107	B18-SF20	M 8~M24	92.5	50	B18	

*Custom-Built products are available on request. *特製品可依客戶需求訂製
*Tap collets to be ordered separately. *絲攻夾頭需另購

Quick Change Tapping Chucks

Features:

- Quick Change of Tap Adapters.
- Special designed for tapping.

快換式絲攻刀桿

特性：

- 快換式絲攻連接桿
- 絲攻專用

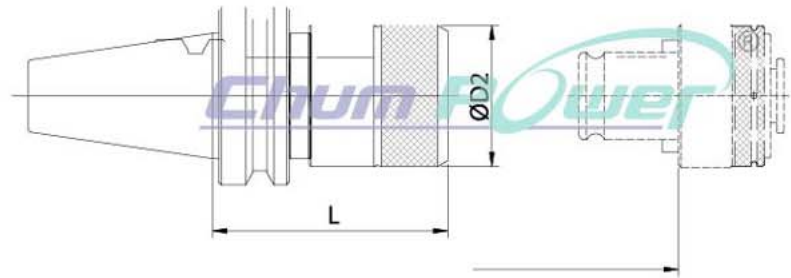

Code NO. 型號	SPEC. 規格	Capacity 攻牙能力	L	øD2	Collets 適用筒夾
36210	BT40-SF12	M 3~M12	60	32	TC312 TC312B
36110	BT40-SF20	M 8~M24	82	50	TC820 TC820B
36310	BT40-SF33	M14~M36	115	76	TC1433 TC1433B

*Custom-Built products are available on request. *特製品可依客戶需求訂製
 *Tap collets to be ordered separately. *絲攻夾頭需另購

- Ⓞ Quick Change Tapping Chucks
- Ⓞ Straight Shank -Collets

Features:

- Quick Change of Tap Adapters.
- Special designed for tapping.

- ▶ 快換式絲攻刀桿
- ▶ 直柄型-筒夾專用

特性:

- 快換式絲攻連接桿
- 絲攻專用

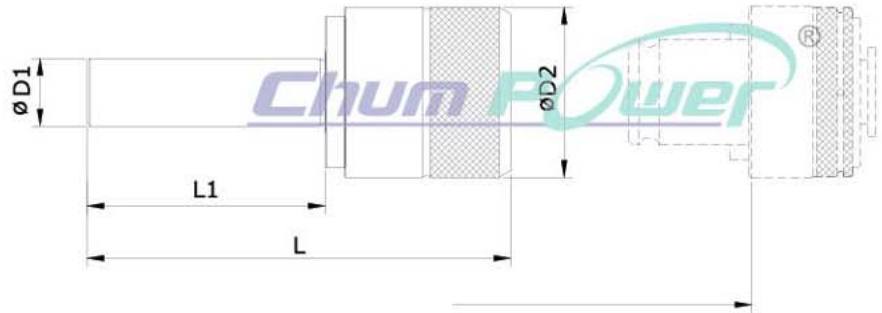

Code NO. 型號	SPEC. 規格	Capacity 攻牙能力	L	L1	øD1	øD2	Collets 適用筒夾
36201	D20-SF12	M 3~M12	104	70	20	32	TC312
36211	D32-SF12	M 3~M12	106	70	32	32	TC312B
36101	D20-SF20	M 8~M24	124	70	20	50	TC820
36111	D32-SF20	M 8~M24	124	70	32	50	TC820B
36301	D25-SF33	M14~M36	169	70	25	76	TC1433
36311	D32-SF33	M14~M36	169	70	32	76	TC1433B

*Custom-Built products are available on request. *特製品可依客戶需求訂製
 *Tap collets to be ordered separately. *絲攻夾頭需另購

- ⊙ Quick Change Tapping Chucks ⊙ 快換式絲攻刀桿
- ⊙ Straight Shank-Side-Lock&CNC Lathe ⊙ 直柄型-側固及CNC車床專用

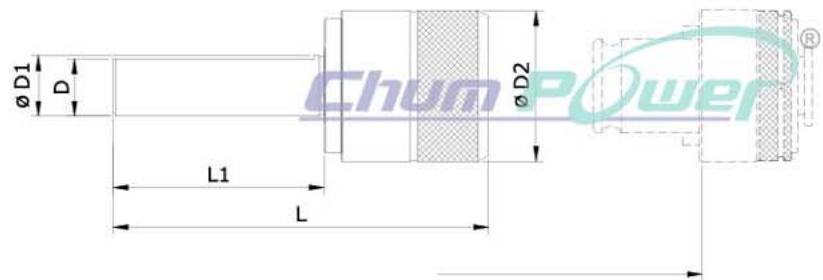

Code NO. 型號	SPEC. 規格	Capacity 攻牙能力	L	L1	D	øD1	øD2	Collets 適用筒夾
36202	D20A-SF12	M 3~M14	104	70	19	20	32	TC312
36212	D32A-SF12	M 3~M14	106	70	31	32	32	TC312B
36102	D20A-SF20	M 8~M24	124	70	19	20	50	TC820
36112	D32A-SF20	M 8~M24	124	70	31	32	50	TC820B
36302	D25A-SF33	M14~M36	169	70	24	25	76	TC1433
36312	D32A-SF33	M14~M36	169	70	31	32	76	TC1433B

*Custom-Built products are available on request. *特製品可依客戶需求訂製
 *Tap collets to be ordered separately. *絲攻夾頭需另購

- ▷ Quick Change Tapping Chucks
- ▷ Morse Taper Shank

- ▷ 快換式絲攻刀桿
- ▷ 莫氏錐度型

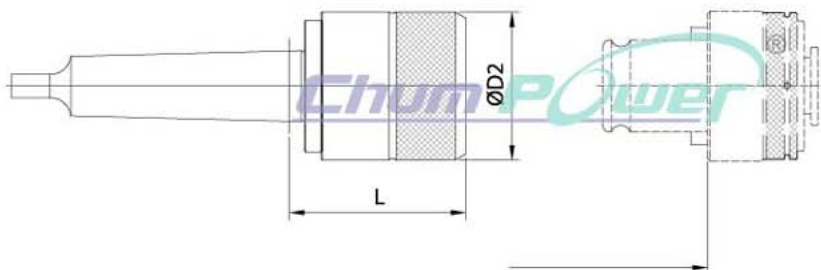

Code NO. 型號	SPEC. 規格	Capacity 攻牙能力	L	øD2	Collets 適用筒夾
36203	MT2-SF12	M 3~M14	39	32	TC312 TC312B
36204	MT3-SF12	M 3~M14	39	32	
36205	MT4-SF12	M 3~M14	34	32	
36103	MT2-SF20	M 8~M24	59	50	TC820 TC820B
36104	MT3-SF20	M 8~M24	59	50	
36105	MT4-SF20	M 8~M24	55	50	
36304	MT3-SF33	M14~M36	104	76	TC1433 TC1433B
36305	MT4-SF33	M14~M36	105	76	

*Custom-Built products are available on request. *特製品可依客戶需求訂製
 *Tap collets to be ordered separately. *絲攻夾頭需另購



- ▶ Quick Change Tap Collets with Overload Clutch
- ▶ JIS Type

Features:

• Overload Clutch is designed to prevent tap from breaking upon tapping.

- ▶ 快換式絲攻夾頭-扭力型
- ▶ JIS

特性:

• 扭力型絲攻設計，可預防絲攻在攻牙時斷裂。

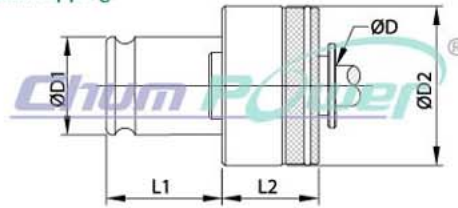

Code NO. 型號	TC312 JIS Tap			Tap Shank 絲攻尺寸 øD柄徑 □四方孔		Capacity 攻牙能力	L1 (mm)	L2 (mm)	øD1 (mm)	øD2 (mm)
35201	M 2			3.0	2.5	M 3~M14	22	25	19	32
35200	M 3		#5, #6	4.0	3.2					
35202	M 4	M4.5	#8	5.0	4.0					
35204	M 5	M5.5	#10	5.5	4.5					
35206	M 6		UNC 1/4	6.0	4.5					
35208			UNC 5/16	6.1	5.0					
35210	M 8	M 7		6.2	5.0					
35212	M10	M 9	UNC 3/8	7.0	5.5					
35213		M11	UNC 7/16	8.0	6.0					
35214	M12			8.5	6.5					
35216			UNC 1/2	9.0	7.0					
35218	M14	M15	UNC 9/16	10.5	8.0					

Code NO. 型號	TC820 JIS Tap			Tap Shank 絲攻尺寸 øD柄徑 □四方孔		Capacity 攻牙能力	L1 (mm)	L2 (mm)	øD1 (mm)	øD2 (mm)
35107	M 5	M5.5	#10	5.5	4.5	M 8~M24	36	30.5	31	50
35105	M 6		UNC 1/4	6.0	4.5					
35101			UNC 5/16	6.1	5.0					
35100	M 8	M 7		6.2	5.0					
35102	M10	M 9	UNC 3/8	7.0	5.5					
35103		M11	UNC 7/16	8.0	6.0					
35104	M12			8.5	6.5					
35106			UNC 1/2	9.0	7.0					
35108	M14	M15	UNC 9/16	10.5	8.0					
35110			UNC 5/8	12.0	9.0					
35112	M16			12.5	10.0					
35113		M17		13.0	10.0					
35114	M18		UNC 3/4	14.0	11.0					
35116	M20			15.0	12.0					
35118	M22		UNC 7/8	17.0	13.0					
35120	M24	M25		19.0	15.0					

Code NO. 型號	TC1433 JIS Tap			Tap Shank 絲攻尺寸 øD柄徑 □四方孔		Capacity 攻牙能力	L1 (mm)	L2 (mm)	øD1 (mm)	øD2 (mm)
35300	M14	M15	UNC 9/16	10.5	8.0	M14~M36	56	45	48	72
35302			UNC 5/8	12.0	9.0					
35304	M16			12.5	10.0					
35306		M17		13.0	10.0					
35308	M18		UNC 3/4	14.0	11.0					
35310	M20			15.0	12.0					
35312	M22		UNC 7/8	17.0	13.0					
35314	M24	M25		19.0	15.0					
35316	M27	M26	UNC 1	20.0	15.0					
35318	M28			21.0	17.0					
35320			UNC 1 1/8	22.0	17.0					
35322	M30			23.0	17.0					
35324	M32		UNC 1 1/4	24.0	19.0					
35326	M33			25.0	19.0					
35328	M35	M34	UNC 1 3/8	26.0	21.0					
35330	M36			28.0	21.0					

*Custom-Built products are available on request. *特製品可依客戶需求訂製

- ▷ Quick Change Tap Collets with Overload Clutch
- ▷ DIN 371 Type

Features:

• Overload Clutch is designed to prevent tap from breaking upon tapping.

- ▷ 快換式絲攻夾頭-扭力型
- ▷ DIN 371

特性:

• 扭力型絲攻設計，可預防絲攻在攻牙時斷裂。

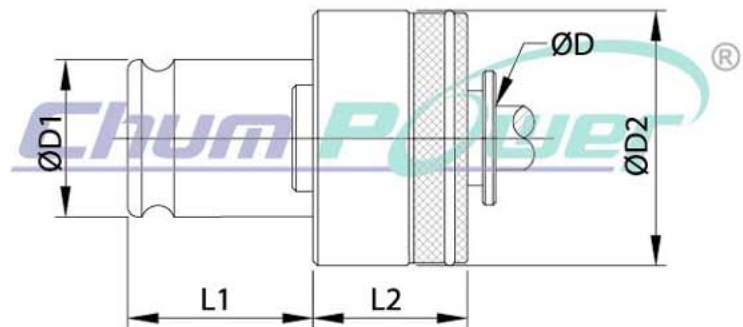

Code NO. 型號	TC312 DIN371 Tap	Tap Shank 絲攻尺寸		Capacity 攻牙能力	L1 (mm)	L2 (mm)	øD1 (mm)	øD2 (mm)
		øD柄徑	□四方孔					
35223	M1~M1.8	2.5	2.1	M3~M14	22	25	19	32
35224	M2~M2.5	2.8	2.1					
35225	M3	3.5	2.7					
35226	M3.5	4.0	3.0					
35227	M4	4.5	3.4					
35228	M4.5	6.0	4.9					
35229	M5	6.0	4.9					
35230	M6	6.0	4.9					
35231	M8	8.0	6.2					
35232	M10	10.0	8.0					

Code NO. 型號	TC820 DIN371 Tap	Tap Shank 絲攻尺寸		Capacity 攻牙能力	L1 (mm)	L2 (mm)	øD1 (mm)	øD2 (mm)
		øD柄徑	□四方孔					
35130	M5	6.0	4.9	M8~M24	36	30.5	31	50
35131	M6	6.0	4.9					
35132	M8	8.0	6.2					
35133	M10	10.0	8.0					

*Custom-Built products are available on request. *特製品可依客戶需求訂製

- ⊙ Quick Change Tap Collets with Overload Clutch
- ⊙ DIN376 Type

- ⊙ 快換式絲攻夾頭-扭力型
- ⊙ DIN376

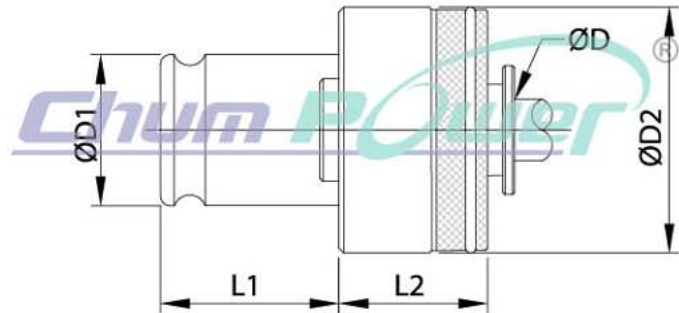

Code NO. 型號	TC312 DIN 376 Tap	Tap Shank 絲攻尺寸		Capacity 攻牙能力	L1 (mm)	L2 (mm)	øD1 (mm)	øD2 (mm)
		øD柄徑	□四方孔					
35240	M3.5	2.5	2.1	M3~M14	22	25	19	32
35242	M 4	2.8	2.1					
35244	M4.5	3.5	2.7					
35246	M 5	3.5	2.7					
35248	M 6	4.5	3.4					
35250	M 7	5.5	4.3					
35252	M 8	6.0	4.9					
35254	M10	7.0	5.5					
35256	M12	9.0	7.0					
35258	M14	11.0	9.0					

Code NO. 型號	TC820 DIN 376 Tap	Tap Shank 絲攻尺寸		Capacity 攻牙能力	L1 (mm)	L2 (mm)	øD1 (mm)	øD2 (mm)
		øD柄徑	□四方孔					
35134	M 8	6.0	4.9	M8~M24	36	30.5	31	50
35136	M10	7.0	5.5					
35138	M12	9.0	7.0					
35140	M14	11.0	9.0					
35142	M16	12.0	9.0					
35144	M18	14.0	11.0					
35146	M20	16.0	12.0					
35148	M22	18.0	14.5					
35150	M24	18.0	14.5					

Code NO. 型號	TC1433 DIN 376 Tap	Tap Shank 絲攻尺寸		Capacity 攻牙能力	L1 (mm)	L2 (mm)	øD1 (mm)	øD2 (mm)
		øD柄徑	□四方孔					
35336	M14	11.0	9.0	M14~M36	56	45	48	72
35338	M16	12.0	9.0					
35340	M18	14.0	11.0					
35342	M20	16.0	12.0					
35344	M22	18.0	14.5					
35346	M24	18.0	14.5					
35348	M27	20.0	16.0					
35350	M30	22.0	18.0					
35352	M33	25.0	20.0					
35354	M36	28.0	22.0					

*Custom-Built products are available on request. *特製品可依客戶需求訂製

- ▷ Quick Change Tap Collets with Overload Clutch
- ▷ ISO 529 Type

- ▷ 快換式絲攻夾頭-扭力型
- ▷ ISO 529

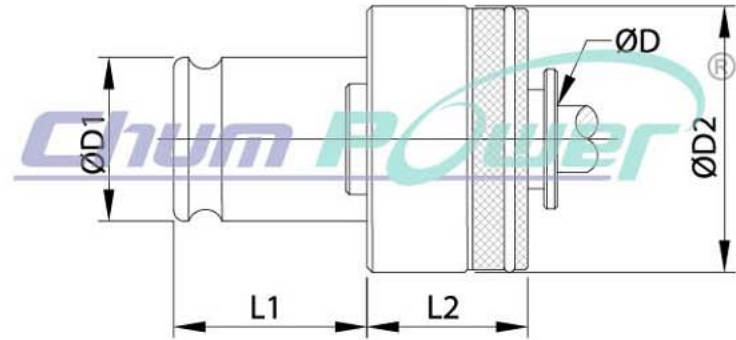

Code NO. 型號	TC312 ISO 529 Tap	Tap Shank 絲攻尺寸		Capacity 攻牙能力	L1 (mm)	L2 (mm)	$\varnothing D1$ (mm)	$\varnothing D2$ (mm)
		$\varnothing D$ 柄徑	四方孔					
35261	M1~M2	2.5	2.0	M 3~M14	22	25	19	32
35262	M2.2~M2.5	2.8	2.24					
35263	M 3	3.15	2.5					
35264	M3.5	3.55	2.8					
35265	M 4	4.0	3.15					
35266	M4.5	4.5	3.55					
35267	M 5	5.0	4.0					
35268	M 6	6.3	5.0					
35269	M 7	7.1	5.6					
35270	M 8	8.0	6.3					
35271	M 9	9.0	7.1					
35272	M10	10.0	8.0					

Code NO. 型號	TC820 ISO 529 Tap	Tap Shank 絲攻尺寸		Capacity 攻牙能力	L1 (mm)	L2 (mm)	$\varnothing D1$ (mm)	$\varnothing D2$ (mm)
		$\varnothing D$ 柄徑	四方孔					
35151	M 6	6.3	5.0	M 8~M24	36	30.5	31	50
35152	M 7	7.1	5.6					
35153	M 8	8.0	6.3					
35154	M 9	9.0	7.1					
35155	M10	10.0	8.0					

*Custom-Built products are available on request. *特製品可依客戶需求訂製

- Ⓞ Quick Change Tap Collets with Overload Clutch
- Ⓞ ISO 529/ 2283 Type

- Ⓞ 快換式絲攻夾頭-扭力型
- Ⓞ ISO 529/ 2283

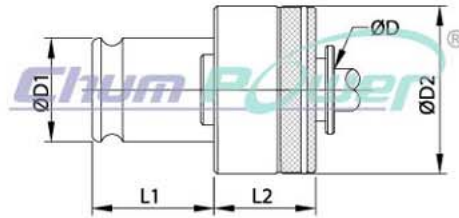

Code NO. 型號	TC312 ISO 529/ 2283 Tap	Tap Shank 絲攻尺寸		Capacity 攻牙能力	L1 (mm)	L2 (mm)	øD1 (mm)	øD2 (mm)
		øD柄徑	□四方孔					
35275	M 3	2.24	1.8	M 3~M14	22	25	19	32
35276	M3.5	2.5	2.0					
35277	M 4	3.15	2.5					
35278	M4.5	3.55	2.8					
35279	M 5	4.0	3.15					
35280	M 6	4.5	3.55					
35281	M 7	5.6	4.5					
35282	M 8	6.3	5.0					
35283	M 9	7.1	5.6					
35284	M10	8.0	6.3					
35285	M12	9.0	7.1					

Code NO. 型號	TC820 ISO 529/ 2283 Tap	Tap Shank 絲攻尺寸		Capacity 攻牙能力	L1 (mm)	L2 (mm)	øD1 (mm)	øD2 (mm)
		øD柄徑	□四方孔					
35156	M 8	6.3	5.0	M 8~M24	36	30.5	31	50
35158	M 9	7.1	5.6					
35160	M10	8.0	6.3					
35162	M12	9.0	7.1					
35164	M14	11.2	9.0					
35166	M16	12.5	10.0					
35168	M18	14.0	11.2					
35170	M20	14.0	11.2					
35172	M22	16.0	12.5					
35174	M24	18.0	14.0					

Code NO. 型號	TC1433 ISO 529/ 2283 Tap	Tap Shank 絲攻尺寸		Capacity 攻牙能力	L1 (mm)	L2 (mm)	øD1 (mm)	øD2 (mm)
		øD柄徑	□四方孔					
35356	M14	11.2	9.0	M14~M36	56	45	48	72
35358	M16	12.5	10.0					
35360	M18	14.0	11.2					
35362	M20	14.0	11.2					
35364	M22	16.0	12.5					
35366	M24	18.0	14.0					
35368	M27	20.0	16.0					
35370	M30	20.0	16.0					
35372	M33	22.4	18.0					
35374	M36	25.0	20.0					

*Custom-Built products are available on request. *特製品可依客戶需求訂製

- ⊕ Quick Change Tap Collets-Rigid Type
- ⊕ JIS Type

- ⊕ 快換式絲攻-剛性
- ⊕ JIS

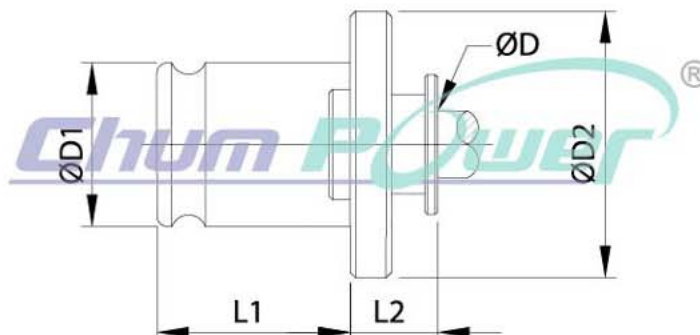

Code NO. 型號	TC312B JIS Tap			Tap Shank 絲攻尺寸		Capacity 攻牙能力	L1 (mm)	L2 (mm)	øD1 (mm)	øD2 (mm)					
				øD柄徑	四方孔										
35401	M 2			3.0	2.5	M 3~M14	22	7	19	30					
35400	M 3		#5, #6	4.0	3.2										
35402	M 4	M4.5	#8	5.0	4.0										
35404	M 5	M5.5	#10	5.5	4.5										
35406	M 6		UNC 1/4	6.0	4.5										
35408			UNC 5/16	6.1	5.0										
35410	M 8	M 7		6.2	5.0										
35412	M10	M 9	UNC 3/8	7.0	5.5										
35413		M11	UNC 7/16	8.0	6.0										
35414	M12			8.5	6.5										
35416			UNC 1/2	9.0	7.0										
35418	M14	M15	UNC 9/16	10.5	8.0										
35500	M 8	M 7		6.2	5.0						M 8~M24	36	11	31	48
35502	M10	M 9	UNC 3/8	7.0	5.5										
35503		M11	UNC 7/16	8.0	6.0										
35504	M12			8.5	6.5										
35506			UNC 1/2	9.0	7.0										
35508	M14	M15	UNC 9/16	10.5	8.0										
35510			UNC5/8	12.0	9.0										
35512	M16			12.5	10.0										
35513		M17		13.0	10.0										
35514	M18		UNC3/4	14.0	11.0										
35516	M20			15.0	12.0										
35518	M22		UNC7/8	17.0	13.0										
35520	M24	M25		19.0	15.0										
35600	M14	M15	UNC 9/16	10.5	8.0	M14~M36	56	14	48	70					
35602			UNC5/8	12.0	9.0										
35604	M16			12.5	10.0										
35606		M17		13.0	10.0										
35608	M18		UNC3/4	14.0	11.0										
35610	M20			15.0	12.0										
35612	M22		UNC7/8	17.0	13.0										
35614	M24	M25		19.0	15.0										
35616	M27	M26	UNC1	20.0	15.0										
35618	M28			21.0	17.0										
35620			UNC1 1/8	22.0	17.0										
35622	M30			23.0	17.0										
35624	M32		UNC1 1/4	24.0	19.0										
35626	M33			25.0	19.0										
35628	M35	M34	UNC1 3/8	26.0	21.0										
35630	M36			28.0	21.0										

*Custom-Built products are available on request. *特製品可依客戶需求訂製

- ⊙ Quick Change Tap Collets_Rigid Type ⊙ 快換式絲攻_剛性
- ⊙ DIN 371 ⊙ DIN 371

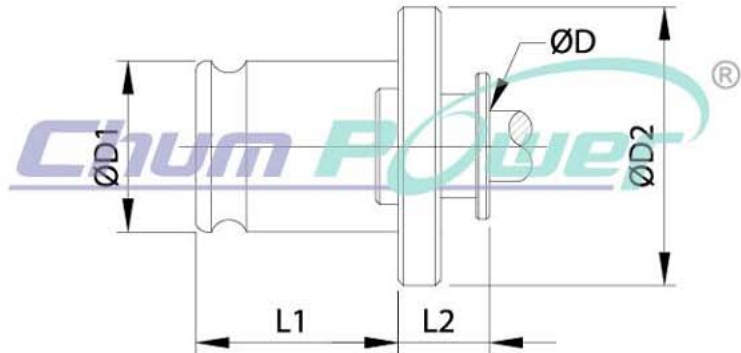

Code NO. 型號	TC 308B DIN371 TAP	Tap Shank 絲攻尺寸		Capacity 攻牙能力	L1 (mm)	L2 (mm)	øD1 (mm)	øD2 (mm)
		øD	□					
35824	M 1~M1.8	2.5	2.1	M 3~M 8	19.5	7	12.65	22
35825	M 2~M2.5	2.8	2.1					
35826	M 3	3.5	2.7					
35827	M3.5	4.0	3.0					
35828	M 4	4.5	3.4					
35829	M4.5	6.0	4.9					
35830	M 5	6.0	4.9					
35831	M 6	6.0	4.9					
35832	M 8	8.0	6.2					

Code NO. 型號	TC312B DIN371 TAP	Tap Shank 絲攻尺寸		Capacity 攻牙能力	L1 (mm)	L2 (mm)	øD1 (mm)	øD2 (mm)
		øD	□					
35423	M 1~M1.8	2.5	2.1	M 3~M14	22	7	19	30
35424	M 2~M2.5	2.8	2.1					
35425	M 3	3.5	2.7					
35426	M3.5	4.0	3.0					
35427	M 4	4.5	3.4					
35428	M4.5	6.0	4.9					
35429	M 5	6.0	4.9					
35430	M 6	6.0	4.9					
35431	M 8	8.0	6.2					
35432	M10	10.0	8.0					

Code NO. 型號	TC820B DIN371 TAP	Tap Shank 絲攻尺寸		Capacity 攻牙能力	L1 (mm)	L2 (mm)	øD1 (mm)	øD2 (mm)
		øD	□					
35529	M4.5	6.0	4.9	M 8~M24	36	11	31	48
35530	M 5	6.0	4.9					
35531	M 6	6.0	4.9					
35532	M 8	8.0	6.2					
35533	M10	10.0	8.0					

*Custom-Built products are available on request. *特製品可依客戶需求訂製



- ⊕ Quick Change Tap Collets-Rigid Type ⊕ 快換式絲攻-剛性
- ⊕ DIN 376 ⊕ DIN 376

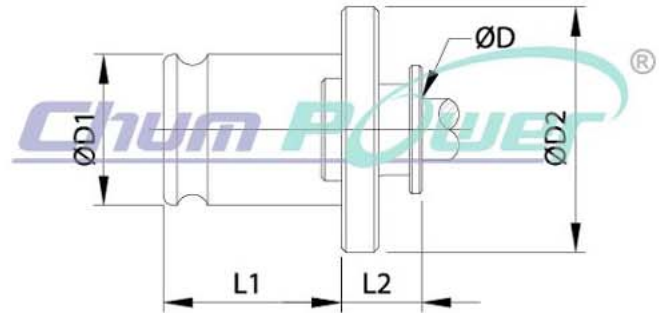

Code NO. 型號	TC 308B DIN376 Tap	Tap Shank 絲攻尺寸		Capacity 攻牙能力	L1 (mm)	L2 (mm)	øD1 (mm)	øD2 (mm)
		øD柄徑	四方孔					
35836	M3.5	2.5	2.1	M3~M8	19.5	7	12.65	22
35838	M4	2.8	2.1					
35840	M4.5	3.5	2.7					
35842	M5	3.5	2.7					
35844	M6	4.5	3.4					
35846	M7	5.5	4.3					
35848	M8	6.0	4.9					
35850	M10	7.0	5.5					
35852	M12	9.0	7.0					
35854	M14	11.0	9.0					
35856	M16	12.0	9.0					

Code NO. 型號	TC312B DIN376 Tap	Tap Shank 絲攻尺寸		Capacity 攻牙能力	L1 (mm)	L2 (mm)	øD1 (mm)	øD2 (mm)
		øD柄徑	四方孔					
35440	M3.5	2.5	2.1	M3~M14	22	7	19	30
35442	M4	2.8	2.1					
35444	M4.5	3.5	2.7					
35446	M5	3.5	2.7					
35448	M6	4.5	3.4					
35450	M7	5.5	4.3					
35452	M8	6.0	4.9					
35454	M10	7.0	5.5					
35456	M12	9.0	7.0					
35458	M14	11.0	9.0					

Code NO. 型號	TC820B DIN376 Tap	Tap Shank 絲攻尺寸		Capacity 攻牙能力	L1 (mm)	L2 (mm)	øD1 (mm)	øD2 (mm)
		øD柄徑	四方孔					
35534	M8	6.0	4.9	M8~M24	36	11	31	48
35536	M10	7.0	5.5					
35538	M12	9.0	7.0					
35540	M14	11.0	9.0					
35542	M16	12.0	9.0					
35544	M18	14.0	11.0					
35546	M20	16.0	12.0					
35548	M22	18.0	14.5					
35550	M24	18.0	14.5					

Code NO. 型號	TC1433B DIN376 Tap	Tap Shank 絲攻尺寸		Capacity 攻牙能力	L1 (mm)	L2 (mm)	øD1 (mm)	øD2 (mm)
		øD柄徑	四方孔					
35636	M14	11.0	9.0	M14~M36	56	14	48	70
35638	M16	12.0	9.0					
35640	M18	14.0	11.0					
35642	M20	16.0	12.0					
35644	M22	18.0	14.5					
35646	M24	18.0	14.5					
35648	M27	20.0	16.0					
35650	M30	22.0	18.0					
35652	M33	25.0	20.0					
35654	M36	28.0	22.0					

*Custom-Built products are available on request. *特製品可依客戶需求訂製

- ⦿ Quick Change Tap Collets-Rigid Type ⦿ 快換式絲攻-剛性
- ⦿ ISO 529 ⦿ ISO 529

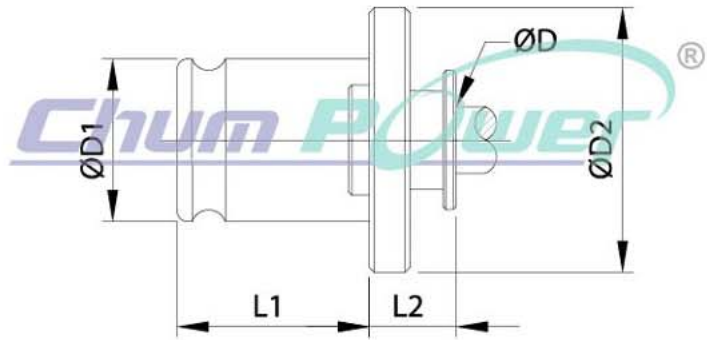

Code NO. 型號	TC312B ISO 529 TAP	Tap Shank 絲攻尺寸		Capacity 攻牙能力	L1 (mm)	L2 (mm)	$\varnothing D1$ (mm)	$\varnothing D2$ (mm)
		$\varnothing D$ 柄徑	四方孔					
35461	M 1~M 2	2.5	2.0	M 3~M14	22	7	19	30
35462	M2.2~M2.5	2.8	2.24					
35463	M 3	3.15	2.5					
35464	M3.5	3.55	2.8					
35465	M 4	4.0	3.15					
35466	M4.5	4.5	3.55					
35467	M 5	5.0	4.0					
35468	M 6	6.3	5.0					
35469	M7	7.1	5.6					
35470	M 8	8.0	6.3					
35471	M 9	9.0	7.1					
35472	M10	10.0	8.0					

Code NO. 型號	TC820B ISO 529 TAP	Tap Shank 絲攻尺寸		Capacity 攻牙能力	L1 (mm)	L2 (mm)	$\varnothing D1$ (mm)	$\varnothing D2$ (mm)
		$\varnothing D$ 柄徑	四方孔					
35551	M 6	6.3	5.0	M 8~M24	36	11	31	48
35552	M 7	7.1	5.6					
35553	M 8	8.0	6.3					
35554	M 9	9.0	7.1					
35555	M10	10.0	8.0					

*Custom-Built products are available on request. *特製品可依客戶需求訂製

- ⊙ Quick Change Tap Collets - Rigid Type ⊙ 快換式絲攻-剛性
- ⊙ ISO 529/2283 ⊙ ISO 529/2283

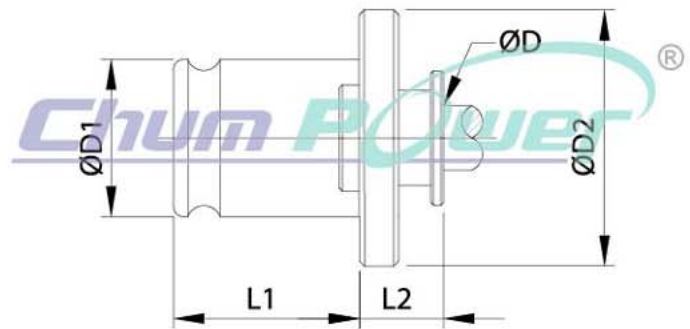

Code NO. 型號	TC312B ISO 529/ 2283 Tap	Tap Shank 絲攻尺寸 øD柄徑 □四方孔	Capacity 攻牙能力	L1 (m/m)	L2 (m/m)	øD1 (m/m)	øD2 (m/m)
35475	M 3	2.24 1.8	M 3~M14	22	7	19	30
35476	M3.5	2.5 2.0					
35477	M 4	3.15 2.5					
35478	M4.5	3.55 2.8					
35479	M 5	4.0 3.15					
35480	M 6	4.5 3.55					
35481	M 7	5.6 4.5					
35482	M 8	6.3 5.0					
35483	M 9	7.1 5.6					
35484	M10	8.0 6.3					
35485	M12	9.0 7.1					
35486	M14	11.2 9.0					
Code NO. 型號	TC820B ISO 529/ 2283 Tap	Tap Shank 絲攻尺寸 øD柄徑 □四方孔	Capacity 攻牙能力	L1 (m/m)	L2 (m/m)	øD1 (m/m)	øD2 (m/m)
35556	M 8	6.3 5.0	M 8~M24	36	11	31	48
35558	M 9	7.1 5.6					
35560	M10	8.0 6.3					
35562	M12	9.0 7.1					
35564	M14	11.2 9.0					
35566	M16	12.5 10.0					
35568	M18	14.0 11.2					
35570	M20	14.0 11.2					
35572	M22	16.0 12.5					
35574	M24	18.0 14.0					
Code NO. 型號	TC1433B ISO 529/ 2283 Tap	Tap Shank 絲攻尺寸 øD柄徑 □四方孔					
35656	M14	11.2 9.0	M14~M36	56	14	48	70
35658	M16	12.5 10.0					
35660	M18	14.0 11.2					
35662	M20	14.0 11.2					
35664	M22	16.0 12.5					
35666	M24	18.0 14.0					
35668	M27	20.0 16.0					
35670	M30	20.0 16.0					
35672	M33	22.4 18.0					
35674	M36	25.0 20.0					

*Custom-Built products are available on request. *特製品可依客戶需求訂製

- ⦿ Quick Change Tap Collets with Overload Clutch
- ⦿ JIS Type

- ⦿ 快換式絲攻夾頭-扭力型
- ⦿ JIS

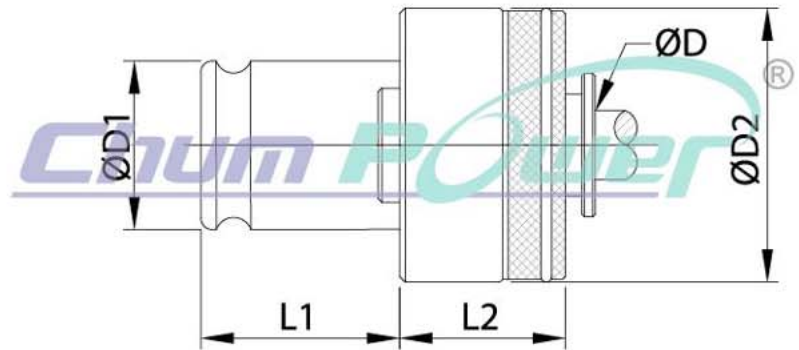

Code NO. 型號	TC312 JIS Tap	Tap Shank	絲攻尺寸	Capacity 攻牙能力	L1 (mm)	L2 (mm)	øD1 (mm)	øD2 (mm)
		øD柄徑	□四方孔					
35219	PT 1/8	8.0	6.0	PT 1/8 ~ PT 1/4	22	25	19	32
35220	PT 1/4	11.0	9.0					
Code NO. 型號	TC820 JIS Tap	Tap Shank	絲攻尺寸	Capacity 攻牙能力	L1 (mm)	L2 (mm)	øD1 (mm)	øD2 (mm)
		øD柄徑	□四方孔					
35121	PT 1/8	8.0	6.0	PT 1/8 ~ PT 1/2	36	30.5	31	50
35122	PT 1/4	11.0	9.0					
35123	PT 3/8	14.0	11.0					
35124	PT 1/2	18.0	14.0					
Code NO. 型號	TC1433 JIS Tap	Tap Shank	絲攻尺寸	Capacity 攻牙能力	L1 (mm)	L2 (mm)	øD1 (mm)	øD2 (mm)
		øD柄徑	□四方孔					
35331	PT 1/4	11.0	9.0	PT 1/4 ~ PT 1"	56	45	48	72
35332	PT 3/8	14.0	11.0					
35333	PT 1/2	18.0	14.0					
35334	PT 3/4	23.0	17.0					
35335	PT 1	26.0	21.0					

*Custom-Built products are available on request. *特製品可依客戶需求訂製

- ⊙ Quick Change Tap Collets-Rigid Type ⊙ 快換式絲攻-剛性
- ⊙ JIS Type ⊙ JIS

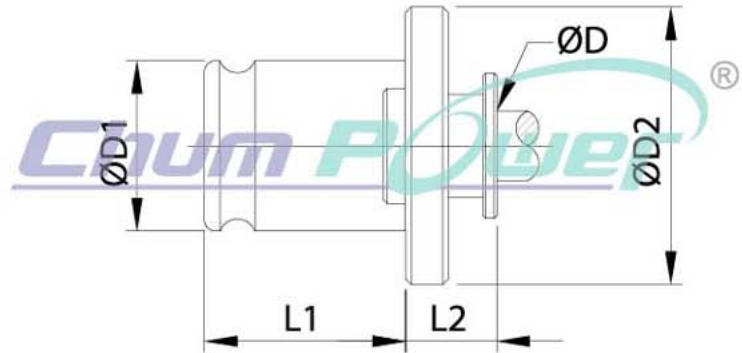

Code NO. 型號	TC 308B JIS Tap	Tap Shank øD柄徑	絲攻尺寸 □四方孔	Capacity 攻牙能力	L1 (mm)	L2 (mm)	øD1 (mm)	øD2 (mm)
35818	PT 1/8	8.0	6.0	PT 1/8 ~ PT 1/4	19.5	7	12.65	22
35820	PT 1/4	11.0	9.0					
Code NO. 型號	TC312B JIS Tap	Tap Shank øD柄徑	絲攻尺寸 □四方孔	Capacity 攻牙能力	L1 (mm)	L2 (mm)	øD1 (mm)	øD2 (mm)
35419	PT 1/8	8.0	6.0	PT 1/8 ~ PT 1/4	22	7	19	30
35420	PT 1/4	11.0	9.0					
Code NO. 型號	TC820B JIS Tap	Tap Shank øD柄徑	絲攻尺寸 □四方孔	Capacity 攻牙能力	L1 (mm)	L2 (mm)	øD1 (mm)	øD2 (mm)
35521	PT 1/8	8.0	6.0	PT 1/8 ~ PT 1/2	36	11	31	48
35522	PT 1/4	11.0	9.0					
35523	PT 3/8	14.0	11.0					
35524	PT 1/2	18.0	14.0					
Code NO. 型號	TC1433B JIS Tap	Tap Shank øD柄徑	絲攻尺寸 □四方孔	Capacity 攻牙能力	L1 (mm)	L2 (mm)	øD1 (mm)	øD2 (mm)
35631	PT 1/4	11.0	9.0	PT 1/4 ~ PT 1"	56	14	48	70
35632	PT 3/8	14.0	11.0					
35633	PT 1/2	18.0	14.0					
35634	PT 3/4	23.0	17.0					
35635	PT 1	26.0	21.0					

*Custom-Built products are available on request. *特製品可依客戶需求訂製

▷ Tap Chuck Reducer

Features:

- The Tap Chuck Adapter is designed for transferring variety tapping machine system. It is easy to quick change for users and apply in different system tools.

▷ 絲攻轉接頭

特性:

- 絲攻轉接頭之設計目的，是為了轉換各種不同系統的絲攻機台，使用者可容易快換並節省工具成本。

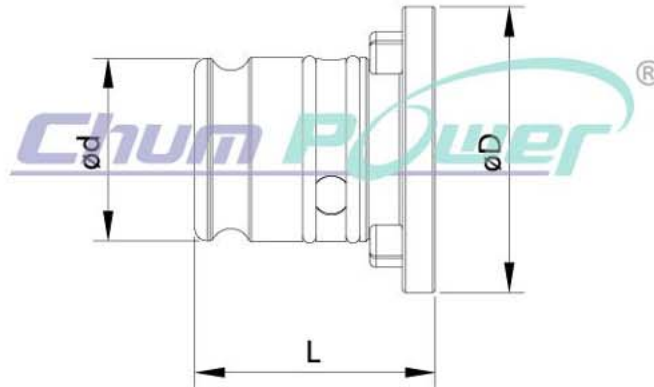

組接示意圖

Code NO. 型號	SPEC. 規格	L	ØD	ød	Collets 適用筒夾	Weight(g) 重量
3600400	TC820→TC312	40.4	48	31	TC312 TC312B	168
3600800	TC1433→TC820	62.6	69	48	TC820 TC820B	558

*Custom-Built products are available on request. *特製品可依客戶需求訂製
*Tap collets to be ordered separately. *絲攻夾頭需另購

▷ Adjustable Pin Wrenches

▷ 調整板手

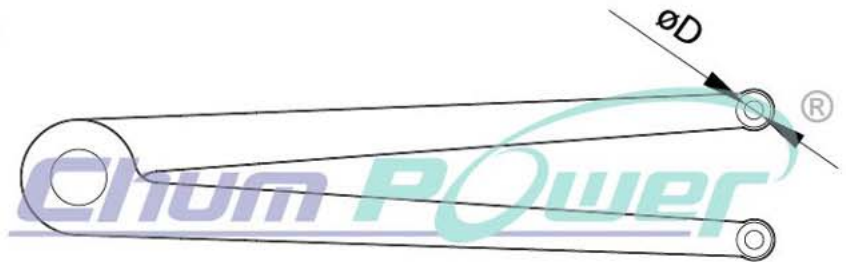

Code NO. 型號	SPEC. 規格	ϕD	Collets 適用筒夾
STA0001	7-40	2.5	TC312 TC820
STA0002	11-60	4	TC1433

*Custom-Built products are available on request. *特製品可依客戶需求訂製

- ▷ Universal Tap Chuck
- ▷ With Inner Taper Hole

- ▷ 泛用型剛性夾頭
- ▷ 內孔型

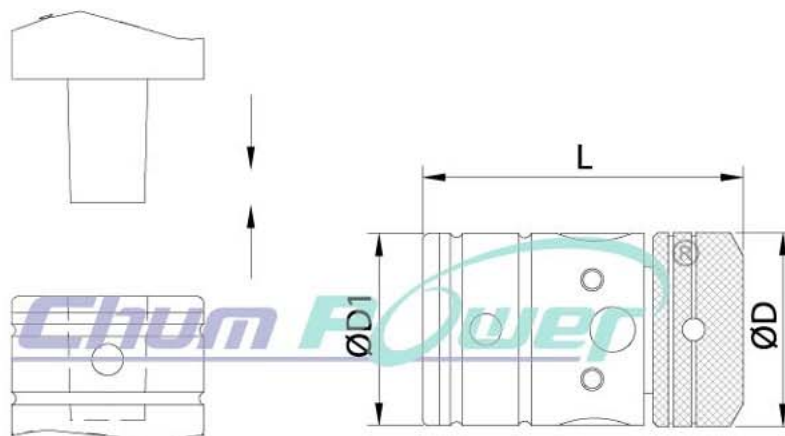

Code NO. 型號	Size 尺寸	Capacity		Taper Mount NO. DIN or Jacobs 錐孔組接型號	L (mm)	$\varnothing D$ (mm)	$\varnothing D1$ (mm)
		mm	inch				
35061	1/2"	M3~M12	1/8"~1/2"	JT6	72.5	43	42.5
35062	1/2"	M3~M12	1/8"~1/2"	JT2	72.5	43	42.5
35063	1/2"	M3~M12	1/8"~1/2"	JT2S	72.5	43	42.5
35065	1/2"	M3~M12	1/8"~1/2"	B16	72.5	43	42.5
35055	5/8"	M3~M16	1/8"~5/8"	JT3			
35056	5/8"	M3~M16	1/8"~5/8"	JT6			
35057	5/8"	M3~M16	1/8"~5/8"	B18			
35081	3/4"	M9~M18	3/8"~3/4"	JT3	82.5	51	49
35083	3/4"	M9~M18	3/8"~3/4"	JT6	82.5	51	49
35085	3/4"	M9~M18	3/8"~3/4"	B18	82.5	51	49

*Custom-Built products are available on request. *特製品可依客戶需求訂製

▷ **Universal Tap Chuck**

▷ **Morse Taper Shank**

Application:

The products are suitable for CNC Machining Centers, CNC Turning Centers, High-Speed Center Lathes, Drilling Machines, Radial Drilling Machines, Air Tapping Machines, Milling Machines and other machines with reversible spindles.

▷ 泛用型剛性夾頭

▷ 莫氏錐度型

用途:

此產品適用於CNC中心加工機, 高速車床, 直立式鑽床, 銑床及其它可反轉的主軸。

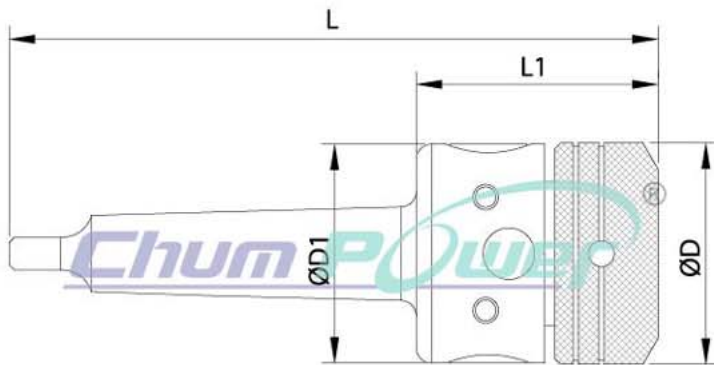

Code NO. 型號	Size 尺寸	Capacity mm	攻牙能力 inch	Taper Mount NO. DIN or Jacobs 錐孔組接型號	L (mm)	L1 (mm)	øD (mm)	øD1 (mm)	Weight(g) 重量
35015	1/2"	M3~M12	1/8"~1/2"	MT2	129	49	43	42.5	
35017	1/2"	M3~M12	1/8"~1/2"	MT3	148	49	43	42.5	
35051	5/8"	M3~M16	1/8"~5/8"	MT2	136	60	48.5	46	732
35052	5/8"	M3~M16	1/8"~5/8"	MT3		60	48.5	46	
35031	3/4"	M9~M18	3/8"~3/4"	MT2	143.5	58	51	49	924
35033	3/4"	M9~M18	3/8"~3/4"	MT3	162.5	58	51	49	1074
35035	3/4"	M9~M18	3/8"~3/4"	MT4	187.5	58	51	49	1380

*Custom-Built products are available on request. *特製品可依客戶需求訂製

Air tapping Machine 氣動攻牙機



- ⊕ Air tapping spindle
- ⊕ Parallel arm
- ⊕ Table mounting column
- ⊕ Air unit
- ⊕ Complete specifications

- ⊕ 氣動攻牙機主軸
- ⊕ 伸長臂
- ⊕ 固定座
- ⊕ 三點組合
- ⊕ 規格齊全



機櫃Cabinet : SMB9901

Code No. 型號	Type 規格	Capacity 攻牙能力	Spindle R.P.M 主軸轉速	Work Place 工作範圍
SMB0001	SW-0708	M8	700 R.P.M	Rmax 700 mm
SMB0002	SW-0712	M12	400 R.P.M	
SMB0003	SW-0716	M16	250 R.P.M	
SMB0004	SW-0720	M20	200 R.P.M	
SMB0005	SW-0722	M22	200 R.P.M	
SMB0006	SW-0724	M24	100 R.P.M	
SMB0007	SW-1408	M8	700 R.P.M	Rmax 1400 mm
SMB0008	SW-1412	M12	400 R.P.M	
SMB0009	SW-1416	M16	250 R.P.M	
SMB0010	SW-1420	M20	200 R.P.M	
SMB0011	SW-1422	M22	200 R.P.M	
SMB0012	SW-1424	M24	100 R.P.M	
SMB0013	SW-1608	M8	700 R.P.M	Rmax 1600 mm
SMB0014	SW-1612	M12	400 R.P.M	
SMB0015	SW-1616	M16	250 R.P.M	
SMB0016	SW-1620	M20	200 R.P.M	
SMB0017	SW-1622	M22	200 R.P.M	
SMB0018	SW-1624	M24	100 R.P.M	
SMB0019	SW-1908	M8	700 R.P.M	Rmax 1900 mm
SMB0020	SW-1912	M12	400 R.P.M	
SMB0021	SW-1916	M16	250 R.P.M	
SMB0022	SW-1920	M20	200 R.P.M	
SMB0023	SW-1922	M22	200 R.P.M	
SMB0024	SW-1924	M24	100 R.P.M	