

Chum POWER

EX-POWER Universal Chuck

泛用型夾頭系列

B





Design Features

- Suitable for every kind of machine tool cutters.
- Capable of drilling, tapping and twist Milling etc.
- The best sharp weapon against the depressed economic.
- Special structure with worldwide patents.
- Able to clamp the tool for two-way machining.

設計特色

- 適合所有類型的切削工具機。
- 能鑽孔、攻牙、銑床加工。
- 是打擊低迷景氣最好的利器。
- 獨特設計，全球專利。
- 能雙向轉動夾持刀具。

HOOK WRENCH DIN1810A 勾扳手
 #600



Code No. 型號	Size 尺寸	Weight 重量 (g)
BA1281000001A	8mm	100
BA1601300002A	13mm	160
BA1601600001A	16mm	250

Integral Universal Chucks
 一體式夾頭操作說明

GRIP 鎖緊



RELEASE 鬆開



Clockwise(CW)
 順時針方向



Counter-clockwise(CCW)
 逆時針方向



EX-POWER Interchangeable Series 互換系列

#610

These chucks are specially designed for application in CNC drill chucks with the highest engineering standards. The female thread inside the short type BT makes it firmly screwed together with CNC machine.

此類夾頭是特別設計，應用於高工程標準的CNC鑽夾頭。
 BT短型內螺紋可與CNC車床緊密鎖上。

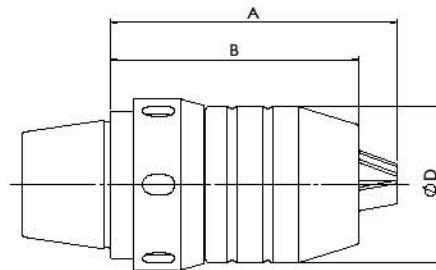

Design Features

- With integrated design, the drill chuck heads once screwed together with tool holder shank will never be disengaged from it.
- Great rigidity due to the special design.
- Excellent performance and reliability.
- High durability and easy to operate.
- Superb accuracy is guaranteed because of 100%.
- All drill chucks are capable combined with SK,ISO,BT,VDI,HSK tool holder.

設計特色

- 一體設計，鑽夾頭與刀把鎖緊不鬆脫。
- 特殊設計，有良好的剛性。
- 性能優異，值得信賴。
- 耐磨損，容易操作。
- 精度準確，經嚴格品質控管。
- 此系列所有鑽夾頭皆可適用SK、ISO、BT、VDI、HSK刀桿。



Fig.2

Code No. 型號	Screw & Chuck Size 螺絲x 夾頭尺寸	Capacity 夾持範圍		Dimensions 規格		
		mm 公制	inch 英制	Close 閉 A / mm	Open 開 B / mm	Outer Dia 外徑 D / mm
BA16108200001A	M8*8mm	0.3-8	1/64-5/16	71	63.8	37.5
BA16113200001A	M8*13mm	0.3-13	1/64-1/2	92	79.5	50
BA16116200001A	M8*16mm	3-16	1/8-5/8	103	91	57

* Custom Built products are available on request. *特製品可依客戶需求訂製

EX-POWER JIS B6339 / MAS 403 BT 一體式系列

integrated / Monoblock Design Series #620

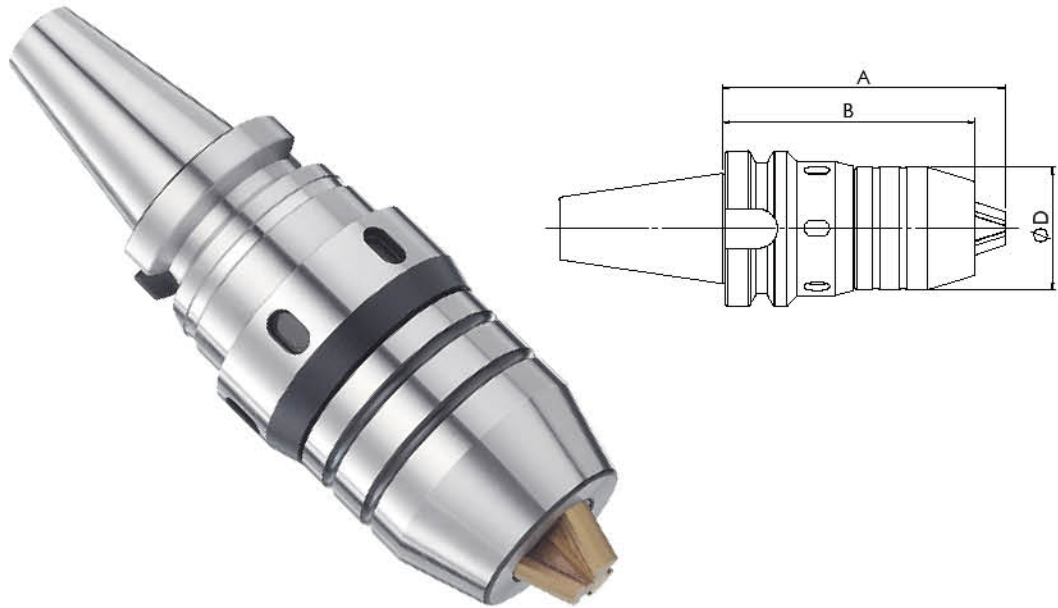

Design Features

- Designed to maximize drill chuck rigidity and precision on machine centers with automatic tool changer.
- The shank and Universal Drill Chuck are combined as one body, so that the Drill Chuck will not be fallen out when heavy cutting performed.
- The drill will not be dropped out when the main spindle of machine instantly stops.
- High precision can be maintained over a long period of time.

設計特色

- 設計功能 - 增強鑽夾頭的堅固性及精準性，於使用綜合加工中心機的換刀系統。
- 刀柄和鑽夾頭結合為一體，即使是做重切削的加工，鑽夾頭也不會脫落。
- 即使機器主軸立即停止，刀具也不會因此脫落。
- 超過長時間的使用，此夾頭仍保持高精度。
- 能雙向轉動夾持刀具。

Code No. 型號	Mount Type 組接形式	Size 尺寸	Capacity 夾持範圍		Dimensions 規格		
			mm 公制	inch 英制	Close 閉 A / mm	Open 開 B / mm	Outer Dia 外徑 D / mm
BA2BT30620001A	BT30	8mm	0.3-8	1/64-5/16	90.5	83	37.5
BA2BT30620002A	BT30	13mm	0.3-13	1/64-1/2	114	107	50
BA2BT40620001A	BT40	8mm	0.3-8	1/64-5/16	95	87	37.5
BA2BT40620002A	BT40	13mm	0.3-13	1/64-1/2	115	103	50
BA2BT40620003A	BT40	16mm	3-16	1/8-5/8	121.5	108.5	57

* Custom Built products are available on request. * 特製品可依客戶需求訂製

EX-POWER BT/JIS B6339 組接式系列
 #622

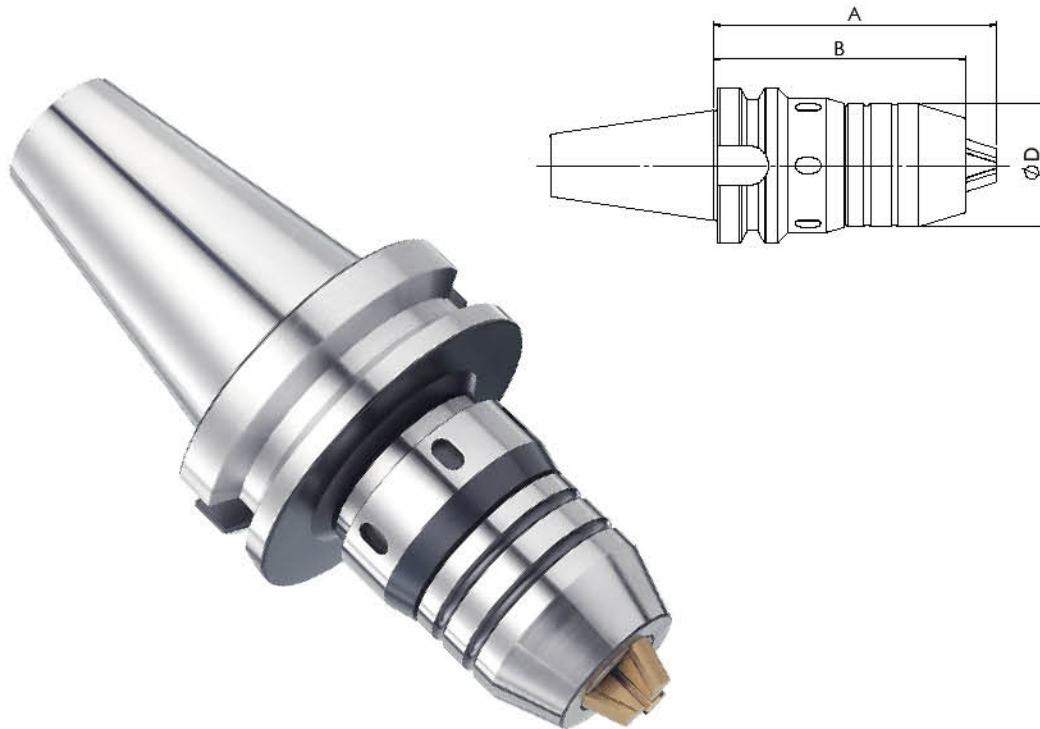

Design Features

- Designed to maximize drill chuck rigidity and precision on machine centers with automatic tool changer.
- High precision can be maintained over a long period of time

設計特色

- 設計功能 - 增強鑽夾頭的堅固性及精準性，於使用綜合加工中心機的換刀系統。
- 超過長時間的使用，此夾頭仍保持高精度。

Code No. 型號	Mount Type 組接形式	Size 尺寸	Capacity 夾持範圍		Dimensions 規格		
			mm 公制	inch 英制	Close 閉 A / mm	Open 開 B / mm	Outer Dia 外徑 D / mm
BA2BT40610001A	BT40	8mm	0.3-8	1/64-5/16	98	91	37.5
BA2BT50610001A	BT50	8mm	0.3-8	1/64-5/16	108.5	101	37.5
BA2BT50610002A	BT50	13mm	0.3-13	1/64-1/2	126.2	115.5	50
BA2BT50610003A	BT50	16mm	3-16	1/8-5/8	132.5	119.5	57

* Custom Built products are available on request. *特製品可依客戶需求訂製