

Spindle Clamping System

D

主軸配件



MAS 403 PULL STUD TYPE CLAMPING

四瓣爪 MAS 403 PULL STUD TYPE CLAMPING

■ Design Features

- All the above materials are composed of alloy steel.
- The Gripper in accordance with the tool standard of MAS 403 system.
- Grippers are developed for integrated and comprise four clamping segments, which is suitable for high and low-speed turning spindles.
- The surfaces of Grippers are wear-resisting, anticorrosive and special tensile force treatment. The tensile force can bear 1,000 KG force which means 1 million times of lifetime testing circle in our each Grippers. (**ie.BT40)
- Easy to assemble and suitable for every type of spindles.
- Our Grippers adopt the rules of BERG standards.

■ 特點

- 四瓣爪材料皆以合金鋼製成
- 此四瓣爪依據 MAS 403 標準工具規範製作
- 一體式分隔爪片設計適用於各種高低轉速之主軸
- 爪片表面經耐磨耗、防腐蝕之特殊處理，拉力經循環壽命測試機測試可承受 1000Kg、100 萬次 (*BT40 為例)
- 採用易拆裝設計，適於各型系列主軸使用
- 同步採用德國 BERG 之說明規範



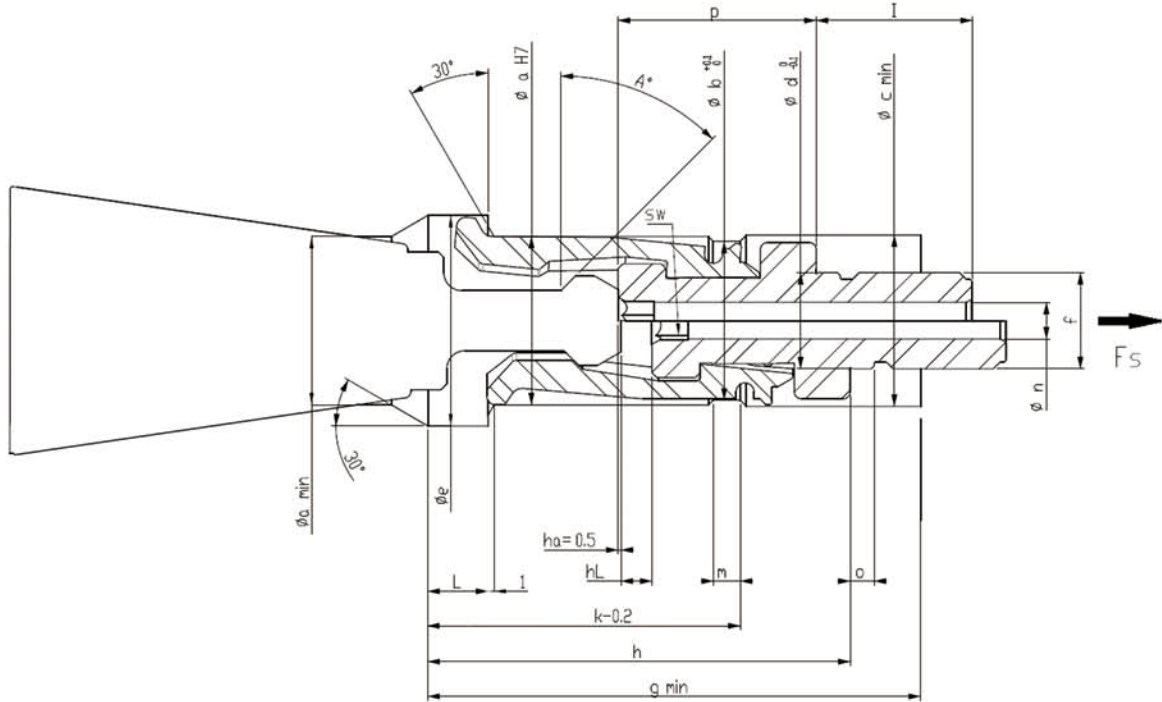

Code No. 型號	TYPE 規格	A*	a	b	c	d	e	g	h	f
BA900BGB30001A	BT30-45°	45°								
BA900BGB30002A	BT30-60°	60°	19	17.8	20.2	10	24	50	47	M10xP1.5
BA900BGB30003A	BT30-90°	90°								
BA900BGB40001A	BT40-45°	45°								
BA900BGB40002A	BT40-60°	60°	28	26.4	28.5	16	35	82	70	M16xP1.5
BA900BGB40003A	BT40-90°	90°								
BA900BGB50001A	BT50-45°	45°								
BA900BGB50002A	BT50-60°	60°	43	40.4	43.5	22	54	98	90	M22xP1.5
BA900BGB50003A	BT50-90°	90°								
BA900BGB60001A	BT60-45°	45°	62	58.6	62.5	30	77	130	125	M30xP1.5

Code No. 型號	TYPE 規格	l	k	L	m	n	o	p	hL	Fs max(kN)	MA(Nm)
BA900BGB30001A	BT30-45°										
BA900BGB30002A	BT30-60°	20	37	7.5	3.5	3	3	21	3	10	20
BA900BGB30003A	BT30-90°										
BA900BGB40001A	BT40-45°										
BA900BGB40002A	BT40-60°	26	52	10	4.5	6	4	33	5	18	65
BA900BGB40003A	BT40-90°										
BA900BGB50001A	BT50-45°										
BA900BGB50002A	BT50-60°	35	69	16	5	9.5	5	37	8	35	160
BA900BGB50003A	BT50-90°										
BA900BGB60001A	BT60-45°	40	96	23	6.5	10.3	5	58.1	10	70	450

* Fs : 最大拉刀力 (Max.clamping Force)
 * MA : 最大鎖緊扭矩 (Max.Tightening Torque)

CAT PULL STUD TYPE CLAMPING

四瓣爪 CAT PULL STUD TYPE CLAMPING

■ Design Features

- All the above materials are composed of alloy steel.
- The Gripper in accordance with the tool standard of ANSI system.
- Grippers are developed for integrated and comprise four clamping segments, which is suitable for high and low-speed turning spindles.
- The surfaces of Grippers are wear-resisting, anticorrosive and special tensile force treatment. The tensile force can bear 1,000 KG force which means 1 million times of lifetime testing circle in our each Grippers. (**ie. CAT40)
- Easy to assemble and suitable for every type of spindles.
- Our Grippers adopt the rules of BERG standards.

■ 特點

- 四瓣爪材料皆以合金鋼製成
- 此四瓣爪依據 ANSI 標準工具規範製作
- 一體式分隔爪片設計適用於各種高低轉速之主軸
- 爪片表面經耐磨耗、防腐蝕之特殊處理，拉力經循環壽命測試機測試可承受 1000Kg、100 萬次 (*CAT40 為例)
- 採用易拆裝設計，適於各型系列主軸使用
- 同步採用德 BERG 之說明規範

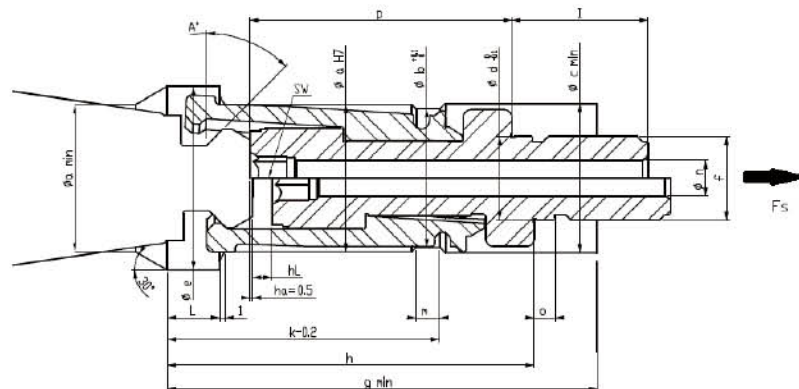

Code No. 型號	TYPE 規格	A*	a	b	c	d	e	g	h	f
BA900BGC30001A	CAT30	45°	19	17.8	19.5	10	24	50	47	M10xP1.5
BA900BGC40001A	CAT40		28	26.4	28.5	16	35	82	70	M16xP1.5
BA900BGC50001A	CAT50		43	40.4	43.5	22	54	98	90	M22xP1.5

Code No. 型號	TYPE 規格	l	k	L	m	n	o	p	hL	Fs max(kN)	MA(Nm)
BA900BGC30001A	CAT30	20	37	7.5	3.5	3	3	33	3	10	30
BA900BGC40001A	CAT40	26	52	10	4.5	7	4	50	4	18	65
BA900BGC50001A	CAT50	35	69	16	5	9.5	5	58	6.5	35	160

* Fs : 最大拉刀力 (Max.clamping Force)

* MA : 最大鎖緊扭矩 (Max.Tightening Torque)

DIN69872 PULL STUD TYPE CLAMPING

四瓣爪 DIN69872 PULL STUD TYPE CLAMPING

■ Design Features

- All the above materials are composed of alloy steel.
- The Gripper in accordance with the tool standard of DIN 69871/69872 system.
 - Grippers are developed for integrated and comprise four clamping segments, which is suitable for high and low-speed turning spindles.
 - The surfaces of Grippers are wear-resisting, anticorrosive and special tensile force treatment. The tensile force can bear 1,000 KG force which means 1 million times of lifetime testing circle in our each Grippers. (**ie. DIN40)
 - Easy to assemble and suitable for every type of spindles.
 - Our Grippers adopt the rules of BERG standards.

■ 特點

- 四瓣爪材料皆以合金鋼製成
- 此四瓣爪依據 DIN 69871/69872 標準工具規範製作
- 一體式分隔爪片設計適用於各種高低轉速之主軸
- 爪片表面經耐磨耗、防腐蝕之特殊處理，拉力經循環壽命測試機測試可承受 1000Kg、100 萬次 (**DIN40 為例)
- 採用易拆裝設計，適於各型系列主軸使用
- 同步採用德國 BERG 之說明規範

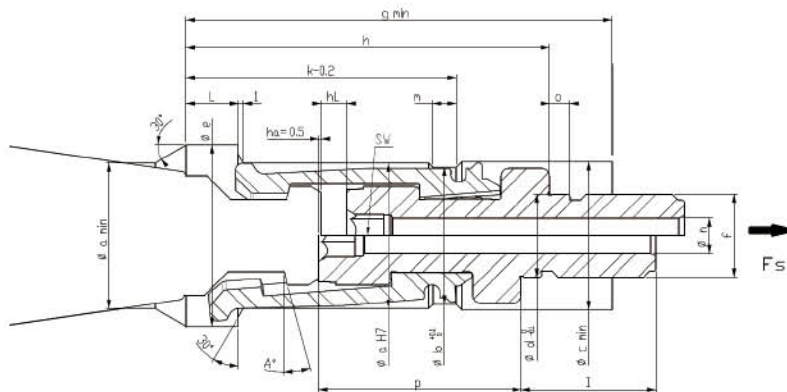

Code No. 型號	TYPE 規格	A*	a	b	c	d	e	g	h	f
BA900BGD30001A	DIN30		19	17.8	20.2	10	24	50	47	M10xP1.5
BA900BGD40001A	DIN40	15°	28	26.4	28.5	16	35	82	70	M16xP1.5
BA900BGD50001A	DIN50		43	40.4	43.5	22	54	98	90	M22xP1.5

Code No. 型號	TYPE 規格	l	k	L	m	n	o	p	hL	Fs max.(kN)	MA(Nm)
BA900BGD30001A	DIN30	20	37	7.5	3.5	3	3	19.5	3.5	10	30
BA900BGD40001A	DIN40	26	52	10	4.5	7	4	39	5	18	65
BA900BGD50001A	DIN50	35	69	16	5	9.5	5	48	8	35	160

* Fs : 最大拉刀力 (Max.clamping Force)

* MA : 最大鎖緊扭矩 (Max.Tightening Torque)

OTT PULL STUD TYPE CLAMPING

四瓣爪 OTT PULL STUD TYPE CLAMPING

■ Design Features

- All the above materials are composed of alloy steel.
- The Gripper in accordance with the tool standard of MAS 403 system.
- Grippers are developed for integrated and comprise four clamping segments, which is suitable for high and low-speed turning spindles.
- The surfaces of Grippers are wear-resisting, anticorrosive and special tensile force treatment. The tensile force can bear 1,000 KG force which means 1 million times of lifetime testing circle in our each Grippers. (**ie.BT40)
- Easy to assemble and suitable for every type of spindles.
- Our Grippers are followed the examples of OTT standards.

■ 特點

- 四瓣爪材料皆以合金鋼製成
- 此四瓣爪依據 MAS 403 標準工具規範製作
- 一體式分隔爪片設計適用於各種高低轉速之主軸
- 爪片表面經耐磨耗、防腐蝕之特殊處理，拉力經循環壽命測試機測試可承受 1000Kg、100 萬次 (*BT40 為例)
- 採用易拆裝設計，適於各型系列主軸使用
- 同步採用德國 OTT 之說明規範



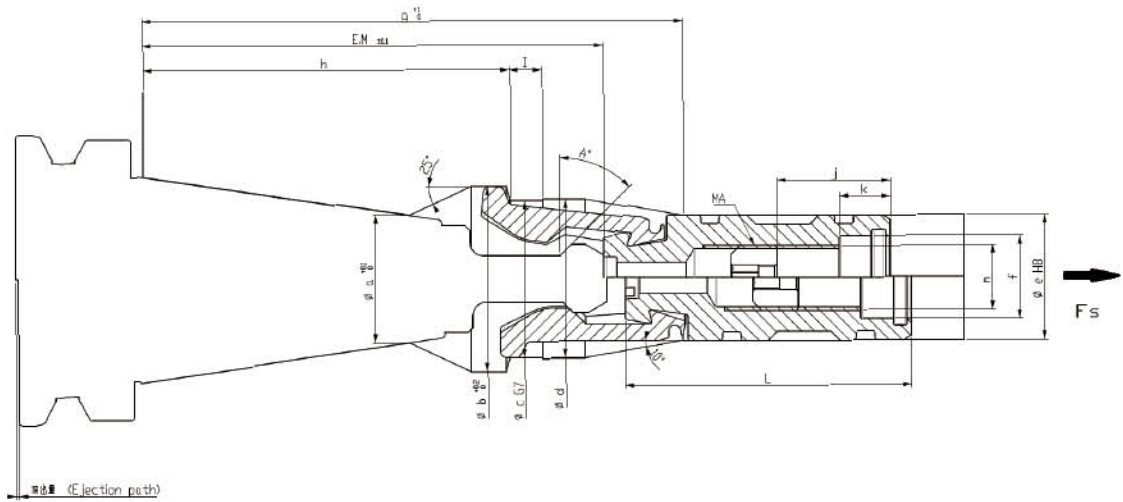

Code No. 型號	TYPE 規格	A*	a	b	c	d	e	f
BA900TTB30001A	BT30-45°	45°	19.5	27	22.5	23	19	12
BA900TTB40001A	BT40-45°	45°	27.6	40	34	34.5	27	18
BA900TTB40002A	BT40-60°	60°						
BA900TTB40003A	BT40-90°	90°						
BA900TTB50001A	BT50-45°	45°	43	56	49	49.5	40	20
BA900TTB50002A	BT50-60°	60°						
BA900TTB50003A	BT50-90°	90°						

Code No. 型號	g	h	i	j	k	L	m	Ejection path 進出量	Fs max. (kN)	MA(Nm)
BA900TTB30001A	91	59	7	23	11	57	M10xP1.25	1	10	30
BA900TTB40001A	117	79.5	7	24.5	11	62	M14xP1.5	0.65	18	65
BA900TTB40002A										
BA900TTB40003A										
BA900TTB50001A	163	116.5	8	31.5	13	68	M16xP1.5	1	35	160
BA900TTB50002A										
BA900TTB50003A										

* Fs : 最大拉刀力 (Max.clamping Force)
 * MA : 最大鎖緊扭矩 (Max.Tightening Torque)

OTT PULL STUD TYPE CLAMPING

四瓣爪 OTT PULL STUD TYPE CLAMPING

■ Design Features

- All the above materials are composed of alloy steel.
- The Gripper in accordance with the tool standard of ANSI system.
- Grippers are developed for integrated and comprise four clamping segments, which is suitable for high and low-speed turning spindles.
- The surfaces of Grippers are wear-resisting, anticorrosive and special tensile force treatment. The tensile force can bear 1,000 KG force which means 1 million times of lifetime testing circle in our each Grippers. (**ie.CAT40)
- Easy to assemble and suitable for every type of spindles.
- Our Grippers are followed the examples of OTT standards.

■ 特點

- 四瓣爪材料皆以合金鋼製成
- 此四瓣爪依據 ANSI 標準工具規範製作
- 一體式分隔爪片設計適用於各種高低轉速之主軸
- 爪片表面經耐磨耗、防腐蝕之特殊處理，拉力經循環壽命測試機測試可承受 1000Kg、100 萬次 (*CAT40 為例)
- 採用易拆裝設計，適於各型系列主軸使用
- 同步採用德國 OTT 之說明規範

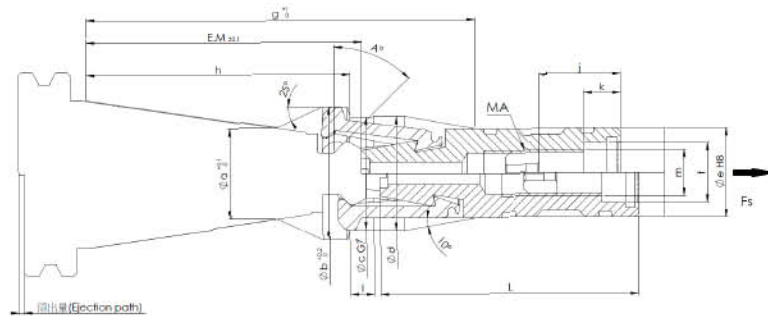

CAT

Code No. 型號	TYPE 規格	A°	a	b	c	d	e	f	g
BA900TTC30001A	CAT30	45°	19.5	27	22.5	23	19	12	91
BA900TTC40001A	CAT40		27.6	40	34	34.5	27	18	117
BA900TTC50001A	CAT50		43	56	49	49.5	40	20	163
Code No. 型號	h	l	j	k	L	m	Ejection path 頂出量	Fs max.(kN)	MA(Nm)
BA900TTC30001A	59	7	23	13	71	M10xP1.25	1.6	10	30
BA900TTC40001A	79.5	7	24.5	11	78	M14xP1.5	1.6	18	65
BA900TTC50001A	116.5	8	31.5	13	87	M16xP1.5	1	35	160

* Fs : 最大拉刀力 (Max.clamping Force)

* MA : 最大鎖緊扭矩 (Max.Tightening Torque)

OTT PULL STUD TYPE CLAMPING

四瓣爪 OTT PULL STUD TYPE CLAMPING

■ Design Features

- All the above materials are composed of alloy steel.
- The Gripper in accordance with the tool standard of DIN 69871 / 69872 system.
- Grippers are developed for integrated and comprise four clamping segments, which is suitable for high and low-speed turning spindles.
- The surfaces of Grippers are wear-resisting, anticorrosive and special tensile force treatment. The tensile force can bear 1,000 KG force which means 1 million times of lifetime testing circle in our each Grippers. (**ie.DIN40)
- Easy to assemble and suitable for every type of spindles.
- Our Grippers are followed the examples of OTT standards.

■ 特點

- 四瓣爪材料皆以合金鋼製成
- 此四瓣爪依據 DIN 69871 / 69872 標準工具規範製作
- 一體式分隔爪片設計適用於各種高低轉速之主軸
- 爪片表面經耐磨耗、防腐蝕之特殊處理，拉力經循環壽命測試機測試可承受 1000Kg、100 萬次 (*DIN40 為例)
- 採用易拆裝設計，適於各型系列主軸使用
- 同步採用德國 OTT 之說明規範

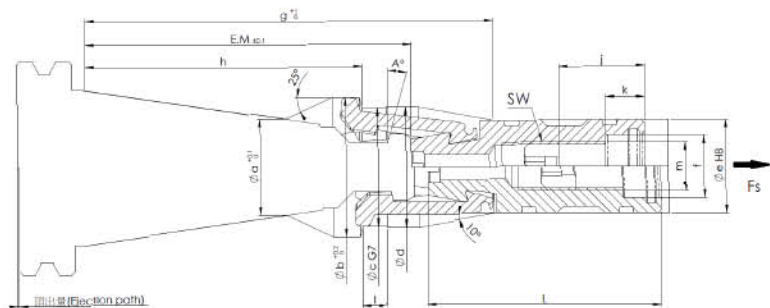

DIN

Code No. 型號	TYPE規格	A*	a	b	c	d	e	f	g
BA900TTD30001A	DIN30	15°	19.5	27	22.5	23	19	12	91
BA900TTD40001A	DIN40		27.6	40	34	34.5	27	18	117
BA900TTD50001A	DIN50		43	56	49	49.5	40	20	163
Code No. 型號	h	i	j	k	L	m	Ejection path 頂出量	Fs max.(kN)	MA(Nm)
BA900TTD30001A	59	7	23	11	57.5	M10xP1.25	1	10	30
BA900TTD40001A	79.5	7	24.5	11	67	M14xP1.5	0.65	18	65
BA900TTD50001A	116.5	8	31.5	13	80	M16xP1.5	1	35	160

* Fs : 最大拉刀力 (Max.clamping Force)

* MA : 最大鎖緊扭矩 (Max.Tightening Torque)

OTT PULL STUD TYPE CLAMPING

四瓣爪 OTT ISO PULL STUD TYPE CLAMPING

■ Design Features

- All the above materials are composed of alloy steel.
- The Gripper in accordance with the tool standard of ISO system.
- Grippers are developed for integrated and comprise four clamping segments, which is suitable for high and low-speed turning spindles.
- The surfaces of Grippers are wear-resisting, anticorrosive and special tensile force treatment. The tensile force can bear 1,000 KG force which means 1 million times of lifetime testing circle in our each Grippers.
- Easy to assemble and suitable for every type of spindles.
- Our Grippers adopt the rules of OTT standards.

■ 特點

- 四瓣爪材料皆以合金鋼製成
- 此四瓣爪依據 ISO 標準工具規範製作
- 一體式分隔爪片設計適用於各種高低轉速之主軸
- 爪片表面經耐磨耗、防腐蝕之特殊處理，拉力經循環壽命測試機測試可承受 1000Kg、100 萬次採用易拆裝設計，適於各型系列主軸使用
- 採用易拆裝設計，適於各型系列主軸使用
- 同步採用德國 OTT 之說明規範

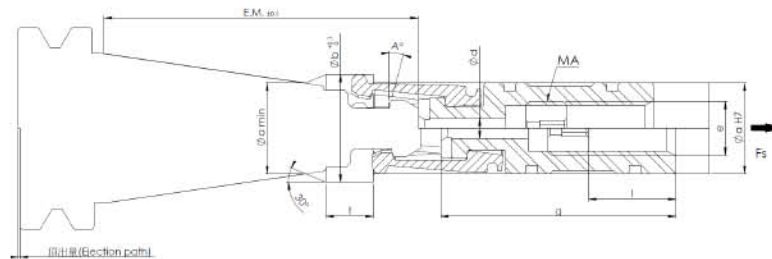

Code No. 型號	TYPE 規格	A'	a	b	c	d	e	f
BA900TTS20001A	ISO 15	15°	12.5	14.5	12.5	2.5	M6xP1	5.5
BA900TTS30001A	ISO 20		13.5	16	13.5	3	M8xP1.25	7
BA900TTS40002A	ISO 25		14	17	14			8

Code No. 型號	g	Ejection path 頂出臺	I	Fs max.(kN)	MA(Nm)
BA900TTS20001A	34	0.3	14	1.7	5
BA900TTS30001A	35	0.3	13	3	6
BA900TTS40002A	42	0.5	14	4	12

* Fs : 最大拉刀力 (Max.clamping Force)

* MA : 最大鎖緊扭矩 (Max.Tightening Torque)

Gripper 倍力夾爪 (S) Force Multiplication System 倍力機構

■ Design Features

- Getting better dynamic characteristics by changing the numbers of washer and the length of spring.
- The stress of spindle is smaller at pulling operation.
- Due to anti-lock mechanism, bearing loading is reduced.
- Tool-changing speed is raised.
- Pulling force is increased and put-in force is lessened in the limited space.
- Lessening the length of pulling system and spindle, which results in the life circle of pulling system prolonged.
- Coating treatment: wear-resistance and anti-corrosion.
- It has been tested by 1.2 million times of performance test.

■ 特點

- 可減少碟形彈片的數置或彈簧長度而得到較佳的動態特性
- 拉刀時，對心軸產生應力較小
- 無需扣住心軸機構，所以對軸承負荷減少
- 提高換刀速度
- 在有限空間下，可增加其拉刀力
- 打刀力可相對減少
- 可減少拉刀系統總長度進而縮短主軸總長度
- 拉刀系統壽命的延長
- 表面經特殊鍍膜處理，耐磨耗、抗腐蝕
- 本系列產品經實機連續壽命測試 120 萬次

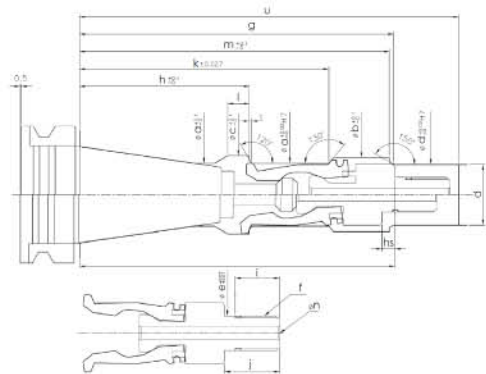

Code No. 型號	TYPE 規格	a	b	c	d	e	f	g	h	i	j	k	l	m	n	p	hs	u
BTFMS902501A	BT30-45°	20	22	24	16	10	M10xP1.5	102	56.5	13.65	17.5	80±0.027	4	100	3	96	4.5	130
BTFMS902502A	BT40-45°	29	34	36	28	16	M16xP1.5	145	78.4	20.5	25.5	115±0.027	10	143	5	145.5	6	175
BTFMS902503A	BT50-45°	44	50	54	38	22	M22xP1.5	214	117.75	27.5	35	176.75±0.032	16	209	6	224.5	9	251
BTFMS902504A	CAT40	29	34	36	28	16	M16xP1.5	145	78.4	20.5	25.5	115±0.027	10	143	5	145.5	6	175
BTFMS902505A	DIN40	29	34	36	28	16	M16xP1.5	145	78.4	20.5	25.5	115±0.027	10	143	5	145.5	6	175
BTFMS902506A	DIN50	44	50	54	38	22	M22xP1.5	214	117.75	27.5	35	176.75±0.032	16	209	6	224.5	9	251

* Fs : 最大拉刀力 (Max.clamping Force)

* MA : 最大鎖緊扭矩 (Max.Tightening Torque)

HSK 瓣爪 HSK Gripper

■ Design Features

- The HSK series are composed of special alloy steel.
- The surfaces of grippers are wear-resistant, anticorrosive of special treatment. 1 million times of lifetime testing circle in our each Grippers. (**ie. HSK63A)
- Our Grippers are followed the examples of OTT standard.

■ 特點

- HSK 系列爪軸、爪片使用特殊合金鋼材質製成。
- 爪軸、爪片表面經耐磨耗、防腐蝕之特殊處理，經循環壽命測試機測試可承受 100 萬次作動 (HSK63A 為例)。
- 同步採用德國 OTT 之說明規範。

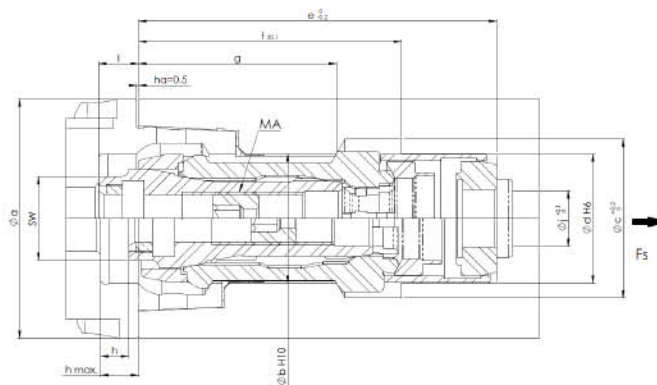

Code No. 型號	TYPE 規格	a	b	c	d	e	f	g
BA900TTH10001A	HSK32A	32	17	22.5	17	62.5	43	30
BA900TTH20001A	HSK40A	40	21	26.5	21	78	58	44
BA900TTH30001A	HSK50A	50	26	33	26	84	61	45
BA900TTH40001A	HSK63A	63	34	41.6	34	94	69	52
BA900TTH50001A	HSK100A	100	53	63	53	124	93	70

Code No. 型號	h	h max.	i	j	Fs max(kN)	MA(Nm)	SW(mm)
BA900TTH10001A	5.1	7.5	8.5	6.6	5	10	12
BA900TTH20001A	5.6	8	8.5	8.6	6.8	15	15
BA900TTH30001A	6.4	9	10.5	10.6	11	20	18
BA900TTH40001A	7.4	10	10.5	14.6	18	30	22
BA900TTH50001A	9.15	12.5	13	18.4	45	50	36

* Fs : 最大拉刀力 (Max.clamping Force)
* MA : 最大鎖緊扭矩 (Max.Tightening Torque)

HSK Gripper 六瓣爪

Balancing Whole Gripper for HSK Toolholder as per DIN 69893

■ Design Features

- Integrated Structure: Easy to be installed.
- High Rigidity. High Durability.
- Special Design: High Reliability.
- Suitable for high-speed machine center. To make HSK Tool-Holders steady.

■ 特點

- 一體式結構，容易安裝。
- 剛性好，耐用。
- 特殊設計，作動可靠。
- 使用在 HSK 系列刀桿高速運轉時，平衡穩定。

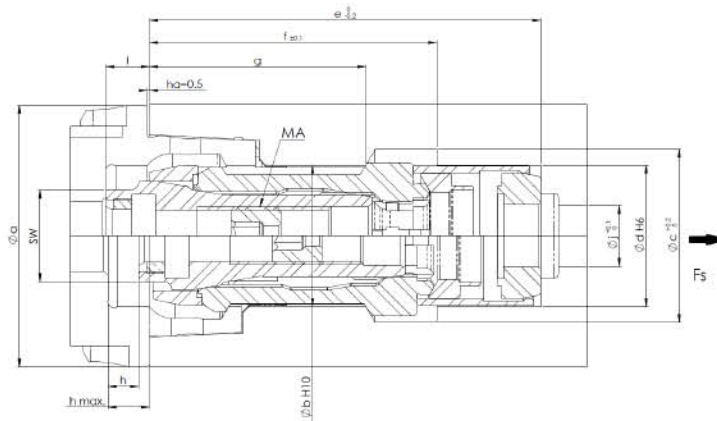

Code No. 型號	TYPE 規格	a	b	c	d	e	f	g
BA900TTH40002A	HSK63A	63	34	41.6	34	94	69	52

Code No. 型號	h	h max.	l	J	Fs max.(kN)	MA(Nm)	SW(mm)
BA900TTH40002A	7.4	10	10.5	14.6	18	30	22

* Fs : 最大拉刀力 (Max.clamping Force)
* MA : 最大鎖緊扭矩 (Max.Tightening Torque)

Shaft Coupling 連軸器

■ Design Features

- According to DIN 69002, which is suitable for multiple spindle drives.
- Developed for stub spindles
 - Integrated clamping system
 - Designed for main spindle drives with high speeds
 - Suitable for peripheral speeds of 50 m/s and more
 - Backlash-free and high precision shaft coupling
 - Easy assembly by clamping and simply screws inside

■ 特點

- 依據 DIN69002 標準製作，適用於複合加工機
- 具完備的短軸規格
- 結合完整的夾具系統
- 針對高轉速主軸設計
- 可適用於圓周回轉速 50m/s 以上
- 具高精度、動平衡結構
- 易拆裝



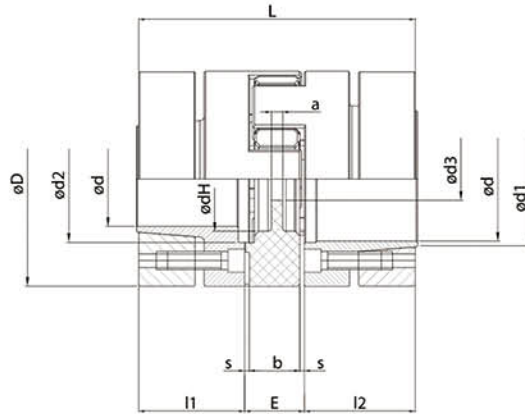

Code No. 型號	Size 尺寸	Dimensions(mm) 規格											
		d	D	dH	L	fl:2	E	b	s	a	d1	d2	d3
BTSAA000101A	14P	14"	32	10.5	50	18.5	13	10	1.5	2	17	17	8.5
BTSAA000102A	19P37.5	16"	37.5	18	66	25	16	12	2	3	20	19	9.5
BTSAA000103A	19P	19"	40	18	66	25	16	12	2	3	23	22	9.5
BTSAA000104A	24P50	24"	50	27	78	30	18	14	2	3	28	29	12.5
BTSAA000105A	24P	25"	55	27	78	30	18	14	2	3	30	30	12.5
BTSAA000106A	28P	35"	65	30	90	35	20	15	2.5	4	40	40	14.5
BTSAA000107A	38P	40"	80	38	114	45	24	18	3	4	46	46	16.5
BTSAA000108A	42P	42"	95	46	126	50	26	20	3	4	52	55	18.5
BTSAA000109A	48P	45"	105	51	140	56	28	21	3.5	4	52	60	20.5
BTSAA000110A	55P	50"	120	60	160	65	30	22	4	4.5	55	72	22.5

齒輪箱或馬達
Driving side gearbox or motor

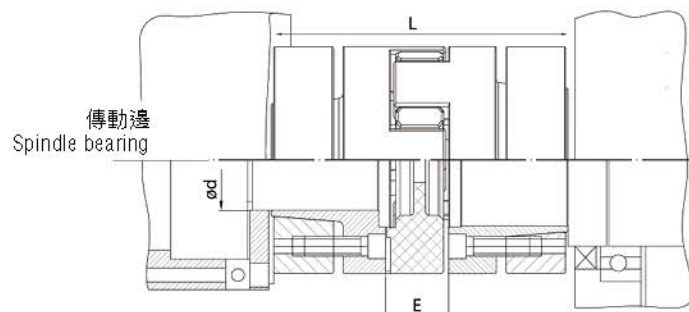

Spindle drive Size	Size	Dimensions(mm) 規格				
		d	D	fl:2	L	E
25x20	14 P	14	32	18.5	50	13
32kx25	19 P37.5	16	37.5	25	66	16
32gx30	19 P	19	40	25	66	16
40x35	24 P50	24	50	30	78	18
50x45	24 P	25	55	30	78	18
63x55	28 P	35	65	35	90	20

Spray Nozzle Series 噴水頭系列

Press Fit Type 壓配型

The Coolant Spray Nozzle could easily adjust its direction and spray precisely. When the coolants correspond with three pressures—low, medium and high pressures, it can precisely aim at workpiece. They are suitable for CNC Machine Center, CNC Lathes, CNC Milling Machine, Grinding Machine and so on. The products can enhance the processing efficiency and accuracy. Also it is helpful for extending the lifetime of tools and decreasing the cost.

可任意調整噴水口角度，並有效對應低、中、高冷卻液液壓，正確噴向瞄準點。適用於綜合切削機、銑床、車床等各式工具機。此項產品除可提高加工效率及精度外，亦有助於延長工具使用壽命和減少成本消耗。



FIG1



FIG2



FIG3

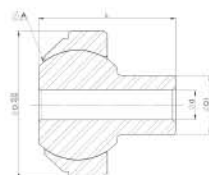

FIG4

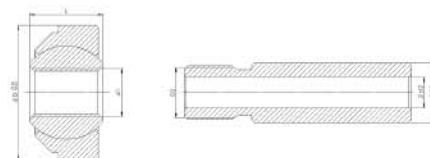

FIG5

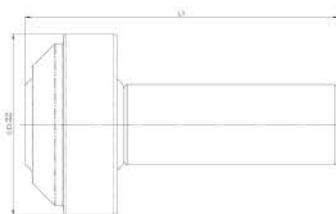

FIG6

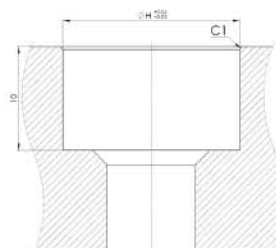

FIG7

Code No. 型號	Nominal dimensions mm 規格										Ball dia 球徑	Allowable fitting angle degree 可調整角度	FIG
	D	H	D1	D2	D3	L	L1	d	d1	d2	A	±α	
BA90101010001A	15	15	-	-	-	8	-	-	Ø4	-	7/16"	29°	1、5
BA90101020001A	15	15	Ø6	-	-	14	-	Ø3	-	-	7/16"	29°	2、4
BA90101020002A	15	15	-	M5xP0.8	Ø6	8	23	-	M5xP0.8	2.5	7/16"	29°	3、5、6
BA90101010002A	12	12	-	-	-	7	-	-	M5xP0.8	-	9mm	28°	1、5
BA90101020003A	15	15	-	M5xP0.8	Ø6	8	19	-	M5xP0.8	2.5	7/16"	29°	3、5、6
BA90101010003A	10	10	-	-	-	5.5	-	-	M4xP0.7	-	7mm	23°	1、5
BA90101020004A	10	10	-	-	Ø4.5	5.5	17.5	-	M4xP0.7	2.3	7mm	23°	3、5、6

Spray Nozzle Series 噴水頭系列

Thread Mount Type 螺紋型

The Coolant Spray Nozzle could easily adjust its direction and spray precisely. When the coolants correspond with three pressures—low, medium and high pressures, it can improve cooling efficiency of tools. They are suitable for CNC Machine Center, CNC Lathes, CNC Milling Machine, Grinding Machine and so on. The products can enhance the processing efficiency and accuracy. Also it is helpful for extending the lifetime of tools and decreasing the cost.

可任意調整噴水口角度，並有效對應低、中、高冷卻液液壓，提高刀具冷卻效率。適用於綜合切削機、銑床、車床等各式工具機。此項產品除可提高加工效率及精度外，亦有助於延長工具使用壽命和減少成本消耗。



Code No. 型號	螺牙規格 (TH)	L	L1	L2	D1	D2	d	H
BA90102020001A	PT1/8	20		9				
BA90102020002A	PT1/8	40	10	29	6	5	4	17
BA90102020003A	PT1/8	60		49				
BA90102020004A	PT1/4	20		9				
BA90102020005A	PT1/4	40	10	29	6	5	4	17
BA90102020006A	PT1/4	60		49				
BA90102020007A	PT3/8	30		13.6				
BA90102020008A	PT3/8	50	13	33.9	8	10	6	24
BA90102020009A	PT3/8	70		45.9				
BA90102020010A	PT1/2	40		16.5				
BA90102020011A	PT1/2	60	18	36.5	10	12	8	32
BA90102020012A	PT1/2	80		56.5				
BA90102020013A	M10xP1.25	20		9				
BA90102020014A	M10xP1.25	40	8	29	6	5	4	17
BA90102020015A	M10xP1.25	60		49				
BA90102020016A	M20xP1.5	30		13.6				
BA90102020017A	M20xP1.5	50	13	33.9	8	10	6	24
BA90102020018A	M20xP1.5	70		45.9				
BA90102020019A	M24xP2	40		16.5				
BA90102020020A	M24xP2	60	18	36.5	10	12	8	31
BA90102020021A	M24xP2	80		56.5				
BA90102020022A	NPT1/4	20		9				
BA90102020023A	NPT1/4	40	10	29	6	5	4	17
BA90102020024A	NPT1/4	60		49				
BA90102020025A	NPT3/8	30		13.6				
BA90102020026A	NPT3/8	50	13	33.9	8	10	6	24
BA90102020027A	NPT3/8	70		45.9				

Spray Nozzle Series 噴水頭系列 (Stainless Type 不銹鋼型)

Thread Mount Type 螺紋型

The Coolant Spray Nozzle could easily adjust its direction and spray precisely. When the coolants correspond with three pressures—low, medium and high pressures, it can improve cooling efficiency of tools. They are suitable for CNC Machine Center, CNC Lathes, CNC Milling Machine, Grinding Machine and so on. The products can enhance the processing efficiency and accuracy. Also it is helpful for extending the lifetime of tools and decreasing the cost.

Moreover, it is accordance with RoHS standard and passed SGS certification which avoids polluting the environment.

可任意調整噴水口角度，並有效對應低、中、高冷卻液液壓，提昇刀具冷卻效率。適用於綜合切削機、銑床、車床等各式工具機。此項產品除可提高加工效率及精度外，亦有助於延長工具使用壽命和減少成本消耗。

符合 RoHS 標準，且高過 SGS 認證，不污染環境。



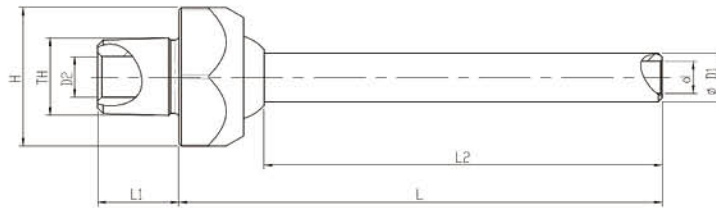

Code No. 型號	螺牙規格 (TH)	L	L1	L2	D1	D2	d	H
BA90103020001A	PT1/8	20		9				
BA90103020002A	PT1/8	40	10	29	6	5	4	17
BA90103020003A	PT1/8	60		49				
BA90103020004A	PT1/4	20		9				
BA90103020005A	PT1/4	40	10	29	6	5	4	17
BA90103020006A	PT1/4	60		49				
BA90103020007A	PT3/8	30		13.6				
BA90103020008A	PT3/8	50	13	33.9	8	10	6	24
BA90103020009A	PT3/8	70		45.9				
BA90103020010A	PT1/2	40		16.5				
BA90103020011A	PT1/2	60	18	36.5	10	12	8	32
BA90103020012A	PT1/2	80		56.5				
BA90103020013A	M10xP1.25	20		9				
BA90103020014A	M10xP1.25	40	8	29	6	5	4	17
BA90103020015A	M10xP1.25	60		49				
BA90103020016A	M20xP1.5	30		13.6				
BA90103020017A	M20xP1.5	50	13	33.9	8	10	6	24
BA90103020018A	M20xP1.5	70		45.9				
BA90103020019A	M24xP2	40		16.5				
BA90103020020A	M24xP2	60	18	36.5	10	12	8	31
BA90103020021A	M24xP2	80		56.5				
BA90103020022A	NPT1/4	20		9				
BA90103020023A	NPT1/4	40	10	29	6	5	4	17
BA90103020024A	NPT1/4	60		49				
BA90103020025A	NPT3/8	30		13.6				
BA90103020026A	NPT3/8	50	13	33.9	8	10	6	24
BA90103020027A	NPT3/8	70		45.9				

Spray Nozzle Series 噴水頭系列

Leak Lock Type 止漏型

Special design for avoiding oil leaking. Not delaying spraying fluid which prolongs the longevity of the tool holders. Slope angle: $\pm 35^\circ$. The angle is easy to adjust by hand. Easy operation and greatest stability when operating. We have Multiple sizes for your reference. Customer requested sizes are available. Leak lock spray nozzle is made by stainless steel. It extends the lifetime of the tools and avoids corrosion. Moreover, it is accordance with RoHS standard and passed SGS certification which avoids polluting the environment. We have self-made testing equipment and QC before delivery. With our quality assurance, you can have confidence in us.

特殊設計可立即停止供給切削液，將不再有切削油滴漏的困擾。且出水不延遲，可延長刀具使用壽命。傾斜角度： $\pm 35^\circ$ ，以手即輕易調整至您希望的角度，容易操作使用且穩定性佳。規格齊全供您選擇，並可依客戶需求訂作。亦有不銹鋼材質的噴水頭，可延長產品壽命，防止生銹。且通過 SGS 認證，符合 RoHS 標準，不污染環境。擁有自製的檢驗設備，出貨前一律全檢，讓您對品質更安心。



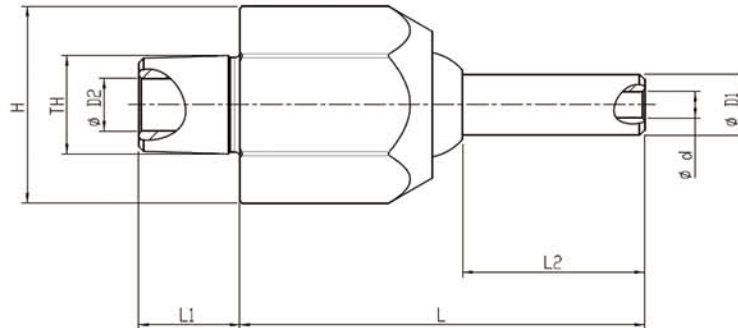

Alloy Steel Type 合金鋼型

Code No. 型號	螺牙規格 (TH)	L	L1	L2	D1	D2	d	H
BA90104020001A	PT1/8	40		18				
BA90104020002A	PT1/8	60		38				
BA90104020003A	PT1/4	40	10	18	6	6	4	17
BA90104020004A	PT1/4	60		38				
BA90104020005A	PT3/8	30		5.9				
BA90104020006A	PT3/8	50	13	25.9	8	10	6	24
BA90104020007A	PT3/8	70		45.9				
BA90104020008A	NPT1/4	40	10	18	6	6	4	17
BA90104020009A	NPT1/4	60		38				
BA90104020010A	NPT3/8	30		5.9				
BA90104020011A	NPT3/8	50	13	25.9	8	10	6	24
BA90104020012A	NPT3/8	70		45.9				
BA90104020013A	M10xP1.25	40	10	18	6	6	4	17
BA90104020014A	M10xP1.25	60		38				
BA90104020015A	M20xP1.5	30		5.9				
BA90104020016A	M20xP1.5	50	13	25.9	8	10	6	24
BA90104020017A	M20xP1.5	70		45.9				

Stainless Type 不銹鋼型

Code No. 型號	螺牙規格 (TH)	L	L1	L2	D1	D2	d	H
BA90105020001A	PT1/8	40		18				
BA90105020002A	PT1/8	60		38				
BA90105020003A	PT1/4	40	10	18	6	6	4	17
BA90105020004A	PT1/4	60		38				
BA90105020005A	PT3/8	30		5.9				
BA90105020006A	PT3/8	50	13	25.9	8	10	6	24
BA90105020007A	PT3/8	70		45.9				
BA90105020008A	NPT1/4	40	10	18	6	6	4	17
BA90105020009A	NPT1/4	60		38				
BA90105020010A	NPT3/8	30		5.9				
BA90105020011A	NPT3/8	50	13	25.9	8	10	6	24
BA90105020012A	NPT3/8	70		45.9				
BA90105020013A	M10xP1.25	40	10	18	6	6	4	17
BA90105020014A	M10xP1.25	60		38				
BA90105020015A	M20xP1.5	30		5.9				
BA90105020016A	M20xP1.5	50	13	25.9	8	10	6	24
BA90105020017A	M20xP1.5	70		45.9				

Spray Nozzle Series 噴水頭系列

Plastic Type 塑材型

The Coolant Spray Nozzle could easily adjust its direction and spray precisely. When the coolants correspond with three pressures—low, medium and high pressures, it can improve cooling efficiency of tools. They are suitable for CNC Machine Center, CNC Lathes, CNC Milling Machine, Grinding Machine and so on. The products can enhance the processing efficiency and accuracy. Also it is helpful for extending the lifetime of tools and decreasing the cost.

可任意調整噴水口角度，並有效對應低、中、高冷卻液液壓，提昇刀具冷卻效率。適用於綜合切削機、銑床、車床等各式工具機。此項產品除可提高加工效率及精度外，亦有助於延長工具使用壽命和減少成本消耗。



FIG1

FIG2

FIG3

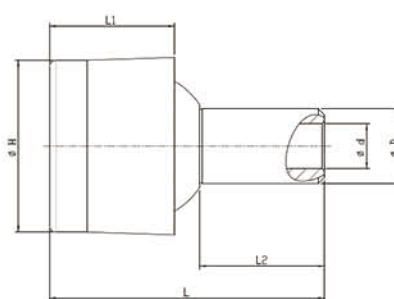
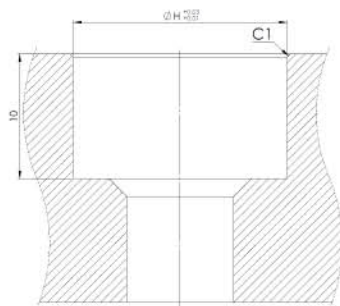

Code No. 型號	ϕH	L	L1	L2	D	d	FIG.
BA90106010001A	10	-	7	-	-	3	1
BA90106010002A	12	-	8	-	-	M5 x P0.8	1
BA90106010003A	14	-	10	-	-	M6 x P1.0	1
BA90106010004A	16	-	11	-	-	M7 x P1.0	1
BA90106020001A	14	17	10	5	6	3	2
BA90106020002A	12	15	8	5.4	5	3	2
BA90106020003A	12	19	8	9.3	5	3	3
BA90106020004A	14	22	10	10	5	3.8	3
BA90106020005A	16	25.5	11	12.5	7	4.4	3

EZ-BAR

LASER COOLANT POINTER 雷射導水筆

Introduction & Features

- The Laser Coolant Pointer is designed for the machines where you need to adjust the coolant Spray Nozzles of the spindle.
- The main purpose is for the operator to correct the angle of coolant water and to prevent the operator from being sprayed by the coolant water. Leading by the laser coolant pointer can be adaptable for every kinds of cutting process (as Fig.1 and Fig.2).
- At the same time, it can improve the trouble of occupying too much space for the traditional adjustable coolant system hoses.

特點

- 雷射導水筆搭配主軸噴水頭即能簡便地校正冷卻水柱與刀具散熱點的角度。
- 雷射導水筆的導引與主軸噴水頭的配合，適用於工具機上的各種切削加工，(如圖1、圖2)並且有助於減少使用者與切削水直接接觸。
- 同時此項產品的設計亦可有效解決傳統噴水軟管占空間的困擾。

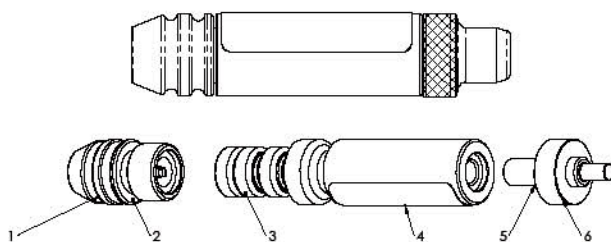
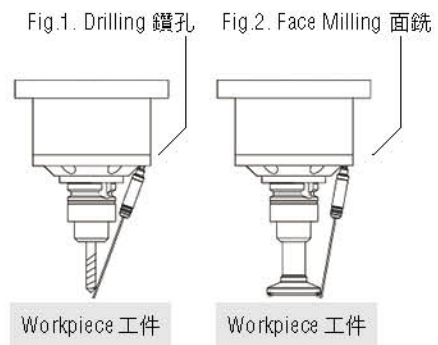

Fig.3. Exploded drawing 分解圖

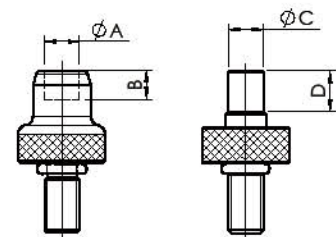

Fig.4. Adapter Spec 分調整接桿規格

Name of each parts (Fig. 3)

1. Laser Head
2. Big O-Ring
3. Battery
4. Body
5. Small O-Ring
6. Adjust Link Stick

各部位名稱 (圖 3)

1. 雷射頭
2. 大口型環
3. 電池
4. 本體
5. 小口型環
6. 調整接桿

The Code No. & Spec. of the Adjust Link Stick (Fig.4) 調整接桿編號與規格，如下表及圖 4 所示

Code No. 型號	Spec.			
	ΦA	ΦB	ΦC	D
BA903LS000001A				
BE 903LS09A	6 mm	5mm	-	-
BE 903LS10A	-	-	4mm	7mm
BE 903LS11A	-	-	5mm	7mm
BE 903LS12A	-	-	6mm	7mm

Installations & Attention

※Please confirm the following steps before installing :

- Please confirm the neck of Laser Head & Adjust Link Stick shall wear the Big O-Ring & Small O-Ring to avoid infiltrating the water.
- The negative of battery shall be headed forward the Laser Head.
- The inner of the Body shall insert the plastic cushion to avoid the results of short circuit in the negative of battery & Body.

※Installation :

- After you confirmed as above, you can assemble the all parts according to Fig.3.

安裝步驟與注意事項

※ 安裝前請確認

- 為避免滲水，請確認雷射頭與調整接桿之頸部套有大 O 型環及小 O 型環。
- 電池負極需朝向雷射頭。
- 本體內部嵌入塑膠墊片，用以避免電池負極與本體造成短路。

※ 安裝

- 確認工作完畢後，依照圖 3 爆炸圖順序裝入即可。

Attention on Usage & Maintenance

- After correcting the position of the Fountain Outlet, please screw out the Adjust Link Stick slightly. It'll avoid the unnecessary consumption for electric power.
- To check the cleanness of the lens of Laser Head as regular. If it is dirty, you can wipe it with the cotton bud.
- To check the O-Ring as regular, if it keeps the elasticity and without transfiguration to avoid infiltrating the water.
- You may not aim to your eyes by 650nm Diode Laser. Otherwise, it'll hurt your retina.

使用與保養注意事項

- 當調整接桿完全旋入本體時，雷射導水筆處於開啓的狀態。
- 噴水口角度位置校正結束後，請將調整接桿略為旋出，避免電量消耗。
- 定期檢查雷射頭鏡面之清潔，骯髒時可使用棉花棒進行擦拭。
- 定期檢查 O 型環是否保持彈性及變形，以避免滲水。
- 不可將紅外線二極體雷射對準眼睛，以避免傷害到視網膜。