

Tooling System

刀桿系統

E



BT CHU CNC DRILL CHUCK

BT直結式鑽夾頭 BT Shank JIS B 6339 (MAS 403 BT)

■ Application / 產品適用

- The product can be adapted for the general lathe or the drilling processing whose machines center can supply with BT spindle.
- 適用於傳統銑床或其他提供 BT 主軸介面之工作母機作鑽孔加工。

■ Feature / 特點

- 3 times better clamping capacity, comparing to keyed drill chucks.
- The drill bit won't be loosen or falling off.
- Twice precision than the keyed drill chucks.
- The drill chuck is interchangeable.
- 比普通夾頭多 3 倍的支持力。
- 鑽頭不會鬆脫或掉落。
- 比普通夾頭多出 2 倍精準。
- 可替換式的夾頭。

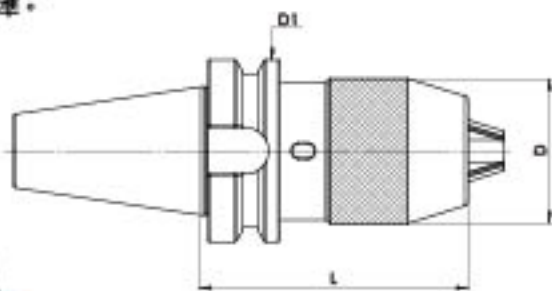

Code No. 型號	TYPE 規格	L	D	D1	Spanner No. 扳手編號
BA2BT30042075A	BT30xCHU8- 75	75	37	46	BA12808000001A
BA2BT30043090A	BT30xCHU13-90	90	50		BA12813000001A
BA2BT40042085A	BT40xCHU8- 85	85	37	63	BA12808000001A
BA2BT40043095A	BT40xCHU13-95	95	50		BA12813000001A
BA2BT40044120A	BT40xCHU16-120	120	57		BA12816000001A
BA2BT50043110A	BT50xCHU13- 110	110	50		BA12813000001A
BA2BT50044110A	BT50xCHU16-110	110	57	100	BA12816000001A

* Custom-built products are available on request

Drill Chuck Torque		
	CHUCKING	Torque(kgf-m)
Keyless Chuck	Hand	0.7kgf-m
CP CHU Chuck	Hand	0.7kgf-m
CP CHU+WRENCH	Wrench	2.2kgf-m

BT ER COLLET CHUCK

BT刀把ER立銼式 BT Shank JIS B 6339 (MAS 403 BT) with Collet Chuck DIN 6499

■ Application / 產品適用

· The product can be applied for end mills, drill bits, drill reamers, taps, and can clamp any straight cutters and tools.

· 本產品可應用於銼刀，鑽頭，絞刀，絲攻及可夾持任何直柄的刀具及工具。

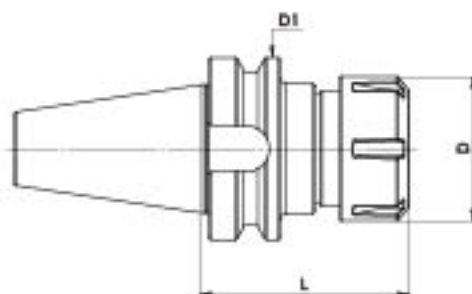

Code No. 型號	TYPE 規格	L	D	D1	Spanner No. 扳手編號
BA2BT30022060B	BT30xER11- 60	60	19	46	BA2ER11020001A
BA2BT30023060B	BT30xER16- 60	60	28		BA2ER16020001A
BA2BT30023100B	BT30xER16- 100	100			
BA2BT30024060B	BT30xER20- 60	60	34		BA2ER20020001A
BA2BT30024100B	BT30xER20- 100	100			
BA2BT30105060B	BT30xER25- 60	60	42		BA2ER25100001A
BA2BT30105100B	BT30xER25- 100	100			
BA2BT30106070B	BT30xER32- 70	70	50		BA2ER32100001A
BA2BT30106100B	BT30xER32- 100	100			
BA2BT40022070B	BT40xER11- 70	70	19		63
BA2BT40022100B	BT40xER11- 100	100			
BA2BT40023070B	BT40xER16- 70	70	28	BA2ER16020001A	
BA2BT40023100B	BT40xER16- 100	100			
BA2BT40024070B	BT40xER20- 70	70	34	BA2ER20020001A	
BA2BT40024100B	BT40xER20- 100	100			
BA2BT40105070B	BT40xER25- 70	70	42	BA2ER25100001A	
BA2BT40105100B	BT40xER25- 100	100			
BA2BT40106070B	BT40xER32- 70	70	50	BA2ER32100001A	
BA2BT40106100B	BT40xER32- 100	100			
BA2BT40107070B	BT40xER40- 70	70	63	BA2ER40100001A	
BA2BT40107100B	BT40xER40- 100	100			
BA2BT40108090B	BT40xER50- 90	90	78		BA2ER50100001A
BA2BT40108100B	BT40xER50- 100	100			

* Custom-built products are available on request.

BT ER COLLET CHUCK

BT 刀把 ER 立銑式 BT Shank JIS B 6339 (MAS 403 BT) with Collet Chuck DIN 6499

■ Application / 產品適用

- The product can be applied for end mills, drill bits, drill reamers, taps, and can clamp any straight cutters and tools.
- 本產品可應用於銑刀，鑽頭，絞刀，絲攻及可夾持任何直柄的刀具及工具。

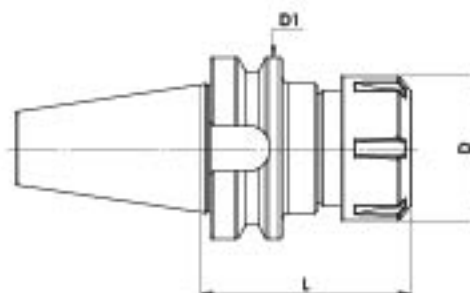

Code No. 型號	Type 規格	L	D	Ø	Spinner No. 型號
BA2BT50023070B	BT50xER16- 70	70	28	100	BA2ER16020001A BA2ER20020001A
BA2BT50023100B	BT50xER16- 100	100			
BA2BT50024070B	BT50xER20- 70	70	34		
BA2BT50024105B	BT50xER20- 105	105			
BA2BT50105070B	BT50xER25- 70	70	42		BA2ER20020001A
BA2BT50105105B	BT50xER25- 105	105			
BA2BT50106080B	BT50xER32- 80	80	50		BA2ER32100001A
BA2BT50106100B	BT50xER32- 100	100			
BA2BT50107080B	BT50xER40- 80	80	63		BA2ER40100001A
BA2BT50108100B	BT50xER50- 100	100			
BA2BT50108120B	BT50xER50- 120	120	78	BA2ER50100001A	

* Custom-built products are available on request

BT MILLING CHUCK

BT 強力式立銑刀把 BT Shank JIS B 6339 (MAS 403 BT)

■ Application / 產品適用

- The Milling chuck can be applied for heavy-duty & higher accuracy cutting.
- 此強力銑刀把適用重型及高精密切削。

■ Feature / 特點

- It is designed with inner rolling needles inside. This design can reduce the friction resistance when tightening and the wear of parts.
- The design of dustproof can prevent iron scrap dropping and extend longevity of chuck.
- The high clamping force is available. The product can prevent the cutting tools from slipping when the users worked it and increase the longevity of cutting tools.
- High rigidity · High precision
- 內部滾針設計，可減少鎖緊時之摩阻力及零件磨耗。
- 防塵設計減少鐵屑掉入以延長使用壽命。
- 高夾持力，防止刀具於加工時滑脫，增加刀具壽命。
- 高剛性 · 高精度

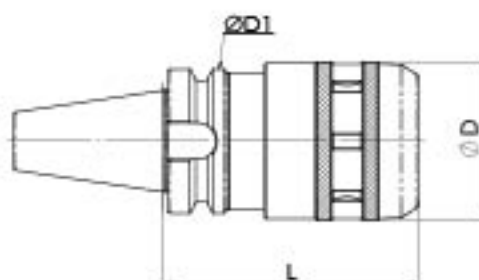

Code No. 型號	TYPE 規格	L	Ø	Ø1	Spindle No. 刀桿編號
BA2BT30032001A	BT30xC20- 80	80	52	46	BA20C20030001A
BA2BT30032501A	BT30xC25- 85	85	60		BA20C25030001A
BA2BT40032001A	BT40xC20- 85	85	52	63	BA20C20030001A
BA2BT40032002A	BT40xC20- 100	100			
BA2BT40032003A	BT40xC20- 135	135			
BA2BT40032501A	BT40xC25- 90	90	60	63	BA20C25030001A
BA2BT40032502A	BT40xC25- 135	135			
BA2BT40033202A	BT40xC32- 105	105	69	63	BA20C32030001A
BA2BT40033203A	BT40xC32- 135	135			
BA2BT50032001A	BT50xC20- 105	105	52	100	BA20C20030001A
BA2BT50032002A	BT50xC20- 150	150	60		
BA2BT50032501A	BT50xC25- 100	100			
BA2BT50032502A	BT50xC25- 150	150	69	100	BA20C25030001A
BA2BT50033201A	BT50xC32- 110	110			
BA2BT50033202A	BT50xC32- 135	135	86	100	BA20C32030001A
BA2BT50034201A	BT50xC42- 110	110			
BA2BT50034203A	BT50xC42- 135	135			BA20C42030001A

* Custom-built products are available on request.

BT CHUCK For High-Speed Machining

BT高速刀桿-高速加工專用

■ Application / 產品適用

- To prevent vibration and reduces noise by SK Nut(Notch-Free).
- High Rigidity · High Accuracy · High Clamping Force
- 藉由 SK 螺母 (無溝槽), 可避免加工時的異動及降低噪音。
- 高剛性 · 高精度 · 高夾持力

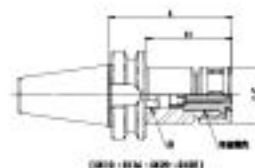
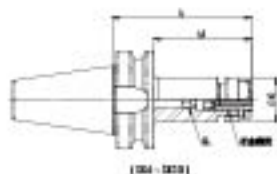

Code No. 型號	TYPE 規格	L	L1	ØC	Ø	Code
BA2BT30251060A	BT30-SK 6- 60	60	38	19.7	M6	SK6
BA2BT30251090A	BT30-SK 6- 90	90	68			
BA2BT30252060A	BT30-SK10- 60	60	38	29	M10	SK10
BA2BT30252090A	BT30-SK10- 90	90	68			
BA2BT30254060A	BT30-SK16- 60	60	38	40	M18	SK16
BA2BT30254090A	BT30-SK16- 90	90	68			
BA2BT30255060A	BT30-SK20- 60	60	38	48.5	M22	SK20
BA2BT30256060A	BT30-SK25- 90	90	68	55	M28	SK25
BA2BT40251060A	BT40-SK 6- 60	60	33			
BA2BT40251090A	BT40-SK 6- 90	90	63	19.7	M6	SK6
BA2BT40251120A	BT40-SK 6- 120	120	93			
BA2BT40252060A	BT40-SK10- 60	60	33			
BA2BT40252090A	BT40-SK10- 90	90	63	29	M10	SK10
BA2BT40252120A	BT40-SK10-120	120	93			
BA2BT40252150A	BT40-SK10-150	150	123			
BA2BT40254060A	BT40-SK16- 60	60	33			
BA2BT40254090A	BT40-SK16- 90	90	63			
BA2BT40254105A	BT40-SK16- 105	105	78			
BA2BT40254120A	BT40-SK16- 120	120	93	40	M18	SK16
BA2BT40254135A	BT40-SK16- 135	135	108			
BA2BT40254150A	BT40-SK16- 150	150	123			
BA2BT40254190A	BT40-SK16- 190	190	163			
BA2BT40255060A	BT40-SK20- 60	60	33			
BA2BT40255090A	BT40-SK20- 90	90	63	48.5	M22	SK20
BA2BT40255120A	BT40-SK20- 120	120	93			
BA2BT40255150A	BT40-SK20- 150	150	123			
BA2BT40256080A	BT40-SK25- 90	90	63	55	M28	SK25
BA2BT40256120A	BT40-SK25- 120	120	93			
BA2BT50251100A	BT50-SK 6-100	100	62	19.7	M6	SK6
BA2BT50251150A	BT50-SK 6-150	150	112			
BA2BT50252100A	BT50-SK10-100	100	62	29	M10	SK10
BA2BT50252150A	BT50-SK10-150	150	112			
BA2BT50254100A	BT50-SK16-100	100	62			
BA2BT50254150A	BT50-SK16-150	150	112	40	M18	SK16
BA2BT50254200A	BT50-SK16-200	200	62			
BA2BT50255100A	BT50-SK20-100	100	112			
BA2BT50255150A	BT50-SK20-150	150	62	48.5	M22	SK20
BA2BT50255200A	BT50-SK20-200	200	112			
BA2BT50256100A	BT50-SK25-100	100	62			
BA2BT50256150A	BT50-SK25-150	150	112	55	M28	SK25
BA2BT50256200A	BT50-SK25-200	200	162			

* Custom-built products are available on request (BT, HSK, SK, HF, CATType) * 特別品 另於客戶需求訂製
 * 詳情請參閱產品目錄 (P.109 頁) * 請向經銷商洽詢 (P.100)

Hydraulic Tool-Holder

油壓刀桿

■ Application / 產品適用

- Reliable for clamping reiteration.
- High Rigidity.
- High Accuracy; No Collet used.
- High Clamping Force.
- Our hydraulic chuck can obtain the run-out within 3 μ m (T.I.R.) at the position 4 ϕ 1 from the nose.
- 重複夾持可靠。
- 高剛性。
- 高精度，因不需使用筒夾。
- 高夾持力。
- 在使用 4 ϕ 1 倍長時，精度為 0.003 μ m。

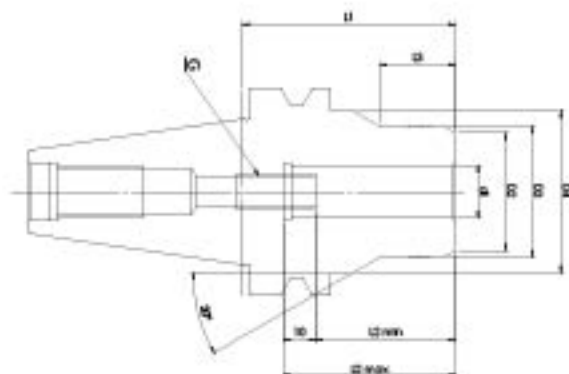

Code No. 型號	TYPE 規格	d1	d2	d3	d4	L1	L2		L3	Q
							M1	M2		
BA2BT40080065A	BT40xCHY6-65	6	26	29	49.5	65	27.5	37.5	23	M5
BA2BT40081065A	BT40xCHY8-65	8	27	30		65	27.5	37.5	23	M6
BA2BT40082065A	BT40xCHY10-65	10	29	32		65	32.5	42.5	23	M8x1
BA2BT40083065A	BT40xCHY12-65	12	31	34		65	37.5	47.5	23	M8x1
BA2BT40084065A	BT40xCHY14-65	14	33	36		65	37.5	47.5	23	
BA2BT40085065A	BT40xCHY16-65	16	36	40		65	42.5	52.5	23	M10x1
BA2BT40086065A	BT40xCHY18-65	18	38	42		65	42.5	52.5	23	M10x1
BA2BT40087065A	BT40xCHY20-65	20	40	44		65	42.5	52.5	23	M10x1
BA2BT40088100A	BT40xCHY25-100	25	55	60	-	100	51	61	-	M16x1
BA2BT40089105A	BT40xCHY32-105	32	58	63	-	105	55	61	-	M16x1

* Custom-built products are available on request. (BT, HB, SK, NT, CAT Type) * 特製品可依客戶需求訂製

Hydraulic Tool-Holder

油壓刀桿

■ Application / 產品適用

- Reliable for clamping reiteration.
- High Rigidity.
 - High Accuracy; No Collet used.
 - High Clamping Force.
 - Our hydraulic chuck can obtain the run-out within 3µm (T.I.R.) at the position 2.5*d1 from the nose.
- 重複夾持可靠。
- 高剛性。
- 高精度，因不需使用筒夾。
- 高夾持力。
- 在使用 4d1 倍長時，精度為 0.003µm。

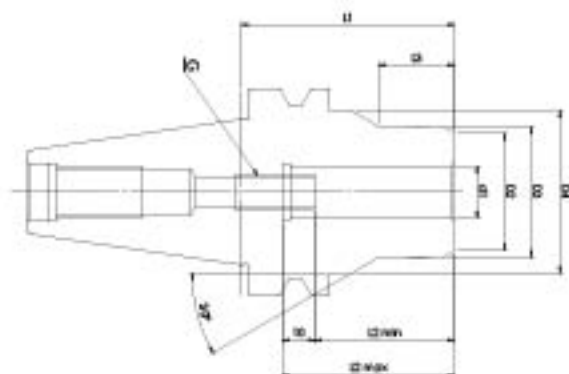

Code No. 型號	TYPE 規格	d1	d2	d3	d4	L1	L2		V	L3	φ
							Min	Max			
BA2BT50080090A	BT50xCHY6- 90	6	26	29	49.5	90	37.5	27.5	10	30	M5
BA2BT50081090A	BT50xCHY8- 90	8	27	30		90	37.5	27.5	10	30	M6
BA2BT50082090A	BT50xCHY10- 90	10	29	32		90	42.5	32.5	10	30	M8x1
BA2BT50083090A	BT50xCHY12- 90	12	31	34		90	47.5	37.5	10	30	M8x1
BA2BT50084090A	BT50xCHY14- 90	14	33	36	63	90	47.5	37.5	10	30	M10x1
BA2BT50085090A	BT50xCHY16- 90	16	36	40		90	52.5	42.5	10	30	M10x1
BA2BT50086090A	BT50xCHY18- 90	18	38	42		90	52.5	42.5	10	30	M10x1
BA2BT50087090A	BT50xCHY20- 90	20	40	44		90	52.5	42.5	10	30	M10x1
BA2BT50088105A	BT50xCHY25-105	25	55	60	-	105	61	51	10	67	M16x1
BA2BT50089090A	BT50xCHY32- 90	32	58	63	-	90	65	55	10	52	M16x1

* Custom-built products are available on request. (BT, HB, SC, NT, CAT Type) * 特製品 均按客戶需求訂製

CAT CHU CNC DRILL CHUCK

CAT直結式鑽夾頭 CAT Shank ANSI B5.50

■ Feature / 特點

- 3 times better clamping capacity, comparing to keyed drill chucks.
- The drill bit won't be loosen or falling off.
- Twice precision than the keyed drill chucks.
- The drill chuck is interchangeable.
- 比普通夾頭多 3 倍的夾持力。
- 鑽頭不會鬆脫或掉落。
- 比普通夾頭多出 2 倍標準。
- 可替換式的夾頭。

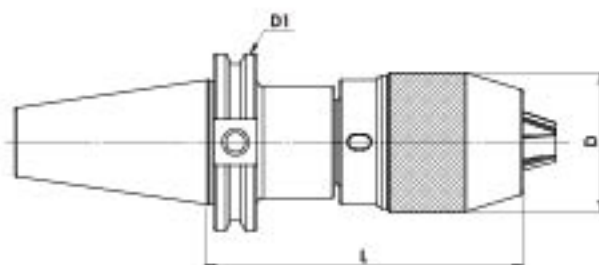

INCH SIZE 英吋

Code No. 型號	TYPE 規格	L	D	D1	Spinner No. 型號
BA2CT30042085A	CAT30xCHU 8-3.347	3.347	1.456	1.812	BA12808000001A
BA2CT40042085A	CAT40xCHU 8-3.228	3.228	1.456	2.5	BA12808000001A
BA2CT40043115A	CAT40xCHU 13-4.527	4.527	1.968	2.5	BA12813000001A
BA2CT40044120A	CAT40xCHU 16-4.724	4.724	2.244	2.5	BA12816000001A
BA2CT50043090A	CAT50xCHU 13-3.54	3.54	1.968	3.875	BA12813000001A
BA2CT50044095A	CAT50xCHU 16-3.7	3.7	2.244	3.875	BA12816000001A

* Custom-built products are available on request.

CAT ER COLLET CHUCK

CAT 刀把 ER 立銼式 CAT Shank ANSI B5.50 with Collet Chuck DIN 6499

■ Application / 產品適用

- The product can be applied for end mills, drill bits, drill reamers, taps, and can clamp any straight cutters and tools.
- 本產品可應用於銼刀，鑽頭，絞刀，絲攻及可夾持任何直柄的刀具及工具。

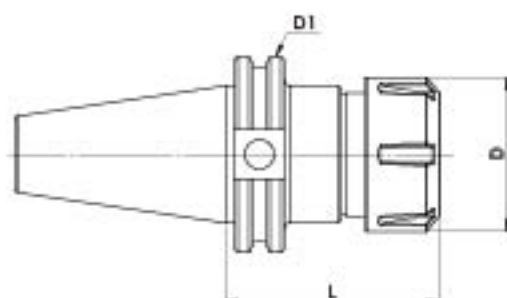

尺吋單位 3000

Code No. 型號	TYPE 規格	L	D	D1	Spinner No. 型號
BA2CT40023070A	CAT40xER16- 2.76	2.76	1.102	2.5	BA2ER16020001A
BA2CT40024070A	CAT40xER20- 2.76	2.76	1.339	2.5	BA2ER20020001A
BA2CT40105070A	CAT40xER25- 2.76	2.76	1.645	2.5	BA2ER25100001A
BA2CT40106070A	CAT40xER32- 2.76	2.76	1.969	2.5	BA2ER32100001A
BA2CT40107080A	CAT40xER40- 3.15	3.15	2.48	2.5	BA2ER40100001A
BA2CT40108102A	CAT40xER50- 4	4	3.07	2.5	BA2ER50100001A
BA2CT50023102A	CAT50xER16- 4	4	1.102	3.875	BA2ER16020001A
BA2CT50024102A	CAT50xER20- 4	4	1.339	3.875	BA2ER20020001A
BA2CT50105102A	CAT50xER25- 4	4	1.645	3.875	BA2ER25100001A
BA2CT50106102A	CAT50xER32- 4	4	1.969	3.875	BA2ER32100001A
BA2CT50107102A	CAT50xER40- 4	4	2.48	3.875	BA2ER40100001A
BA2CT50108102A	CAT50xER50- 4	4	3.07	3.875	BA2ER50100001A

* Custom-built products are available on request

* 特殊規格產品請洽參考 (P.100頁) * 備件規格參考 (P.100-102)

CAT MILLING CHUCK

CAT強力式立銑刀把 CAT Shank ANSI B5.50

■ Application / 產品適用

- The Milling chuck can be applied for heavy-duty & higher accuracy cutting.
- 此強力銑刀把適用重型及高精密切削。

■ Feature / 特點

- It is designed with inner rolling needles inside. This design can reduce the friction resistance when tightening and the wear of parts.
- The design of dustproof can prevent iron scrap dropping and extend longevity of chuck.
- The high clamping force is available. The product can prevent the cutting tools from slipping when the users worked it and increase the longevity of cutting tools.
- High rigidity.
- High precision.
- 內部滾針設計，可減少鎖緊時之摩阻力及零件磨耗。
- 防塵設計減少鐵屑掉入以延長使用壽命。
- 高夾持力，防止刀具於加工時滑脫，增加刀具壽命。
- 高剛性。
- 高精密。

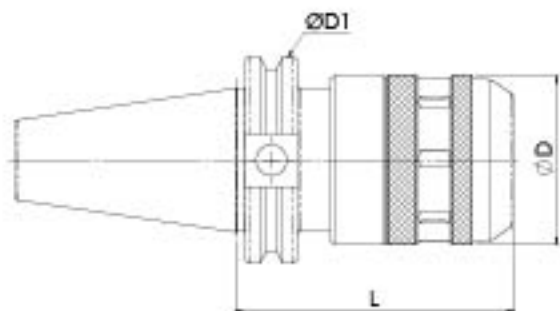

INCH SIZE 英吋

Code No. 型號	Type 規格	L	D	D1	Spanner No. 扳手編號
BA2CT40032051A	CAT40xC3/4- 3.385	3.385	2.047	2.5	BA20C20030001A
BA2CT40033251A	CAT40xC1-1/4- 4.53	4.53	2.716	2.5	BA20C32030001A
BA2CT50032051A	CAT50xC3/4- 4.13	4.13	2.047	3.875	BA20C20030001A
BA2CT50033251A	CAT50xC1-1/4- 4.13	4.13	2.716	3.875	BA20C32030001A

* Custom-built products are available on request.

SK CHU CNC DRILL CHUCK

SK直結式鑽夾頭 SK Shank DIN 69871-A

■ Feature / 特點

- 3 times better clamping capacity, comparing to keyed drill chucks.
- The drill bit won't be loosen or falling off.
 - Twice precision than the keyed drill chucks.
 - The drill chuck is interchangeable.
- 比普通夾頭多 3 倍的夾持力。
- 鑽頭不會鬆脫或掉落。
- 比普通夾頭多出 2 倍精準。
- 可替換式的夾頭。

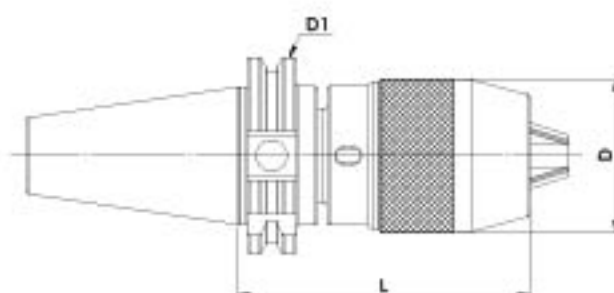

Code P/N 型號	TYPE 規格	L	D	D1	Spinner P/N 夾心螺絲
BA2SK30042000A	SK30xCHU8-80	80	37	50	BA12808000001A
BA2SK30043100A	SK30xCHU13-100	100	50		BA12813000001A
BA2SK30044125A	SK30xCHU16-125	125	57		BA12816000001A
BA2SK40042075A	SK40xCHU8-75	75	37	63.55	BA12808000001A
BA2SK40043100A	SK40xCHU13-100	100	50		BA12813000001A
BA2SK40044115A	SK40xCHU16-115	115	57		BA12816000001A
BA2SK50043100A	SK50xCHU13-100	100	50	97.5	BA12813000001A
BA2SK50044105A	SK50xCHU16-105	105	57		BA12816000001A

* Custom-built products are available on request

SK ER COLLET CHUCK DIN 6499

SK刀把 ER立統式 SK Shank DIN 69871-A with Collet Chuck DIN 6499

■ Application / 產品適用

- The product can be applied for end mills, drill bits, drill reamers, taps, and can clamp any straight cutters and tools.
- 本產品可應用於銼刀，鑽頭，絞刀，絲攻及可夾持任何直柄的刀具及工具。

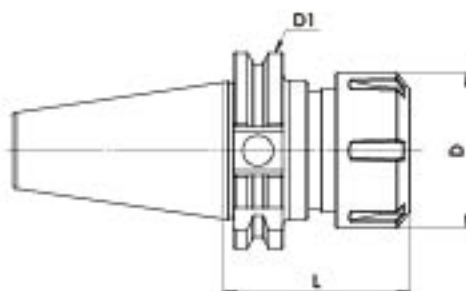

Code No. 型號	TYPE 規格	L	D	D1	Spanner No. 扳手編號
BA2SK30022000A	SK30xER11- 80	80	19	50	BA2ER11020001A
BA2SK30023060A	SK30xER16- 60	60	28		BA2ER16020001A
BA2SK30024060A	SK30xER20- 60	60	34		BA2ER20020001A
BA2SK30105060A	SK30xER25- 60	60	42		BA2ER25100001A
BA2SK30106060A	SK30xER32- 60	60	50		BA2ER32100001A
BA2SK40022000A	SK40xER11- 80	80	19	63.55	BA2ER11020001A
BA2SK40023070A	SK40xER16- 70	70	28		BA2ER16020001A
BA2SK40024070A	SK40xER20- 70	70	34		BA2ER20100001A
BA2SK40024100A	SK40xER20- 100	100	42		BA2ER20100001A
BA2SK40105070A	SK40xER25- 70	70	42		BA2ER25100001A
BA2SK40106060A	SK40xER32- 60	60	50		BA2ER32100001A
BA2SK40107000A	SK40xER40- 80	80	63		BA2ER40100001A
BA2SK40108100A	SK40xER50- 100	100	78	BA2ER50100001A	
BA2SK50023100A	SK50xER16- 100	100	28	97.5	BA2ER16020001A
BA2SK50024100A	SK50xER20- 100	100	34		BA2ER20100001A
BA2SK50105070A	SK50xER25- 70	70	42		BA2ER25100001A
BA2SK50106070A	SK50xER32- 70	70	50		BA2ER32100001A
BA2SK50107070A	SK50xER40- 70	70	63		BA2ER40100001A
BA2SK50108000A	SK50xER50- 80	80	78		BA2ER50100001A

* Custom-built products are available on request.

SK MILLING CHUCK

SK強力式立銑刀把 SK Shank DIN 69871-A

■ Application / 產品適用

- The Milling chuck can be applied for heavy-duty & higher accuracy cutting.
- 此強力銑刀把適用重型及高精密切削。

■ Feature / 特點

- It is designed with inner rolling needles inside. This design can reduce the friction resistance when tightening and the wear of parts.
- The design of dustproof can prevent iron scrap dropping and extend longevity of chuck.
- The high clamping force is available. The product can prevent the cutting tools from slipping when the users worked it and increase the longevity of cutting tools.
- High rigidity.
- High precision.
- 內部滾針設計，可減少鎖緊時之摩阻力及零件磨耗。
- 防塵設計減少鐵屑掉入以延長使用壽命。
- 高夾持力，防止刀具於加工時滑脫，增加刀具壽命。
- 高剛性。
- 高精密。

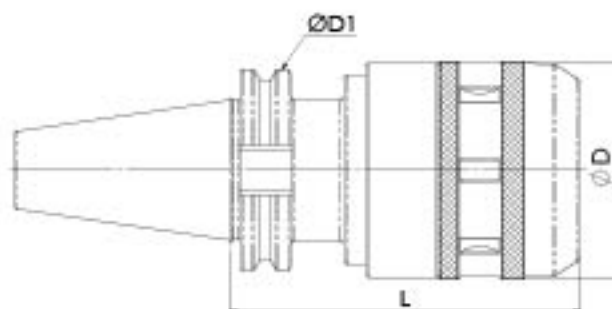

Code No. 型號	Type 規格	L	D	D1	Spanner No. 扳手規格
BA2SK30032001A	SK30xC20- 85	85	52	50	BA20C20030001A
BA2SK40032001A	SK40xC20- 85	85	52	63.55	BA20C20030001A
BA2SK40033201A	SK40xC32- 105	105	69		BA20C32030001A
BA2SK50032001A	SK50xC20- 105	105	52	97.5	BA20C20030001A
BA2SK50033201A	SK50xC32- 110	110	69		BA20C32030001A
BA2SK50034201A	SK50xC42- 110	110	86		BA20C42030001A

* Custom-built products are available on request

HSK CHU CNC DRILL CHUCK

HSK直結式鑽夾頭 HSK Shank DIN 69893-1A

■ Feature / 特點

- 3 times better clamping capacity, comparing to keyed drill chucks.
- The drill bit won't be loosen or falling off.
 - Twice precision than the keyed drill chucks.
 - The drill chuck is interchangeable.
- 比普通夾頭多 3 倍的夾持力。
- 鑽頭不會鬆脫或掉落。
- 比普通夾頭多出 2 倍標準。
- 可替換式的夾頭。

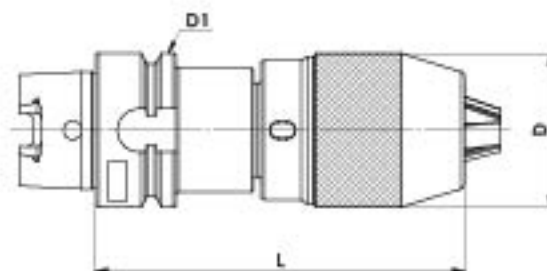

Code No. 型號	TYPE 規格	L	D	D1	Spinner No. 型號
BA2HK50043135A	HSK50A×CHU13[MT2]	135	50	50	BA12813000001A
BA2HK63043145A	HSK63A×CHU13[MT3]	145	50	63	BA12813000001A
BA2HK10043150A	HSK100A×CHU13[MT3]	152	50	100	BA12813000001A

* Custom-built products are available on request.

HSK ER COLLET CHUCK

HSK刀把 ER立銼式 HSK Shank DIN 69893-1A with Collet Chuck DIN 6499

■ Application / 產品適用

- The product can be applied for end mills, drill bits, drill reamers, taps, and can clamp any straight cutters and tools.
- The product matches HSK BBT system (Big+Plus). It can increase the stability on the side direction processing.
- 本產品可應用於銼刀、鑽頭、鉸刀、絲攻及可夾持任何直柄的刀具及工具。
- 搭配 HSK 兩面拘束，可增加側向加工的穩定性。

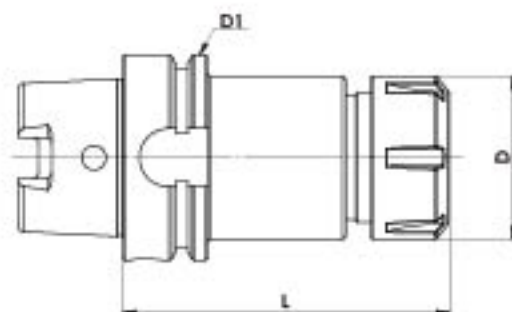

Circle No. 圖號	TYPE 規格	L	D	D1	Spinner No. 系列編號
BA2HK6A024080A	HSK40A×ER20- 80	80	34	40	BA2ER20020001A
BA2HK6A105080A	HSK40A×ER25- 80	80	42	40	BA2ER25100001A
BA2HK5A023080A	HSK50A×ER16- 80	80	28	50	BA2ER16020001A
BA2HK5A024080A	HSK50A×ER20- 80	80	34	50	BA2ER20020001A
BA2HK5A105080A	HSK50A×ER25- 80	80	42	50	BA2ER25100001A
BA2HK5A106100A	HSK50A×ER32- 100	100	50	50	BA2ER32100001A
BA2HK6A023080A	HSK63A×ER16- 80	80	28	63	BA2ER16020001A
BA2HK6A024080A	HSK63A×ER20- 80	80	34	63	BA2ER20020001A
BA2HK6A105080A	HSK63A×ER25- 80	80	42	63	BA2ER25100001A
BA2HK6A106080A	HSK63A×ER32- 80	80	50	63	BA2ER32100001A
BA2HK6A107080A	HSK63A×ER40- 80	80	63	63	BA2ER40100001A
BA2HK6A108120A	HSK63A×ER50- 120	120	78	63	BA2ER50100001A

* Custom-built products are available on request

HSK ER COLLET CHUCK

HSK刀把 ER立銼式 HSK Shank DIN 69893-1A with Collet Chuck DIN 6499

■ Application / 產品適用

- The product can be applied for end mills, drill bits, drill reamers, taps, and can clamp any straight cutters and tools.
- The product matches HSK BBT system (Big+Plus). It can increase the stability on the side direction processing.
- 本產品可應用於銼刀，鑽頭，絞刀，絲攻及可夾持任何直柄的刀具及工具。
- 搭配 HSK 兩面拘束，可增加側向加工的穩定性。

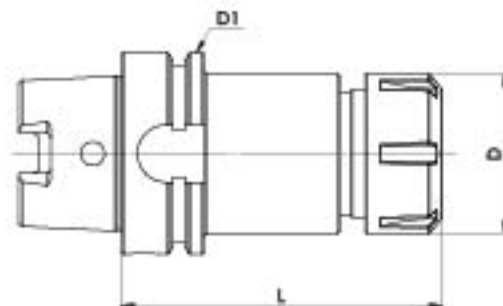

Code No. 型號	TYPE 規格	L	D	D1	Spanner No. 扳手編號
BA2HK1A023080A	HSK100A×ER16- 80	80	28	100	BA2ER16020001A
BA2HK1A024080A	HSK100A×ER20- 80	80	34	100	BA2ER20020001A
BA2HK1A105100A	HSK100A×ER25- 100	100	42	100	BA2ER25100001A
BA2HK1A106100A	HSK100A×ER32- 100	100	50	100	BA2ER32100001A
BA2HK1A107100A	HSK100A×ER40- 100	100	63	100	BA2ER40100001A
BA2HK1A108100A	HSK100A×ER50- 100	100	78	100	BA2ER50100001A

* Custom-built products are available on request.

HSK MILLING CHUCK

HSK強力式立銑刀把 HSK Shank DIN 69893-1A

■ Application / 產品適用

- The Milling chuck can be applied for heavy-duty & higher accuracy cutting.
- The product matches HSK BBT system (Big+Plus). It can increase the stability on the side direction processing.
 - 此強力銑刀把適用重型及高精密切削。
 - 搭配 HSK 兩面拘束，可增加側向加工的穩定性。

■ Feature / 特點

- It is designed with inner rolling needles inside. This design can reduce the friction resistance when tightening and the wear of parts.
- The design of dustproof can prevent iron scrap dropping and extend longevity of chuck.
- The high clamping force is available. The product can prevent the cutting tools from slipping when the users worked it and increase the longevity of cutting tools.
- High rigidity.
- High precision.
- 內部滾針設計，可減少鎖緊時之摩擦阻力及零件磨耗。
- 防塵設計減少鐵屑掉入以延長使用壽命。
- 高夾持力，防止刀具於加工時滑脫，增加刀具壽命。
- 高剛性。
- 高精密。

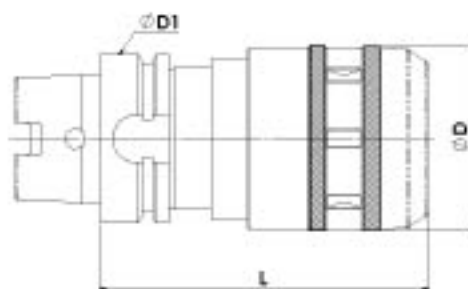

Code / 型號	TYPE / 規格	L	D	D1	Spanner No. / 扳手編號
BA2HK50032001A	HSK50AxC20- 120	120	52	50	BA20C20030001A
BA2HK63032001A	HSK63AxC20- 90	90	52	63	BA20C32030001A
BA2HK63033202A	HSK63AxC32- 120	120	69	63	BA20C42030001A
BA2HK63034201A	HSK63AxC42- 120	120	86	63	BA20C42030001A

* Custom-built products are available on request

BT Hex Key Drill Chuck MAS 403 (JIS B 6339)

BT齒輪式夾頭

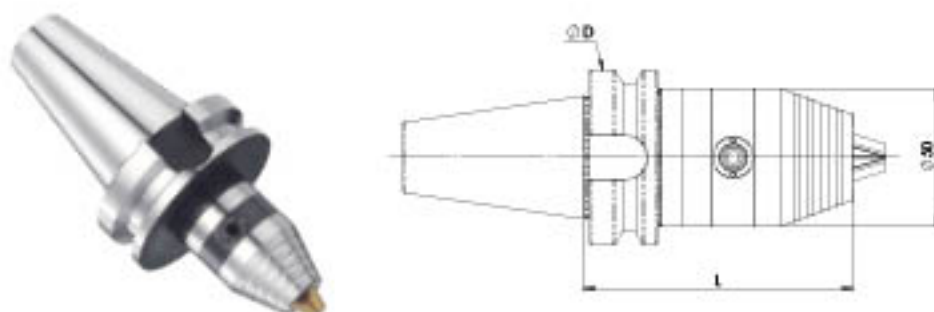

Code No. 型號	TYPE 規格	夾持範圍 Capacity		L	øD	Spanner No. 扳手規格	Weight (g) 重量
		mm.	Inch				
BA2BT30223201A	BT30xGHK13S-100	1-13	3/64-1/2	100	63	BESTC0008	1450
BA2BT30224201A	BT30xGHK16S-105	2.5-16	3/32-5/8	105	100		1460
BA2BT40223201A	BT40xGHK13S-100	1-13	3/64-1/2	100	63		1990
BA2BT40224201A	BT40xGHK16S-105	2.5-16	3/32-5/8	105	63		1990
BA2BT50223201A	BT50xGHK13S-110	1-13	3/64-1/2	110	100		4500
BA2BT50224201A	BT50xGHK16S-115	2.5-16	3/32-5/8	115	100		4360

* Custom-built products are available on request.

SK Hex Key Drill Chuck

SK齒輪式夾頭 DIN 69871

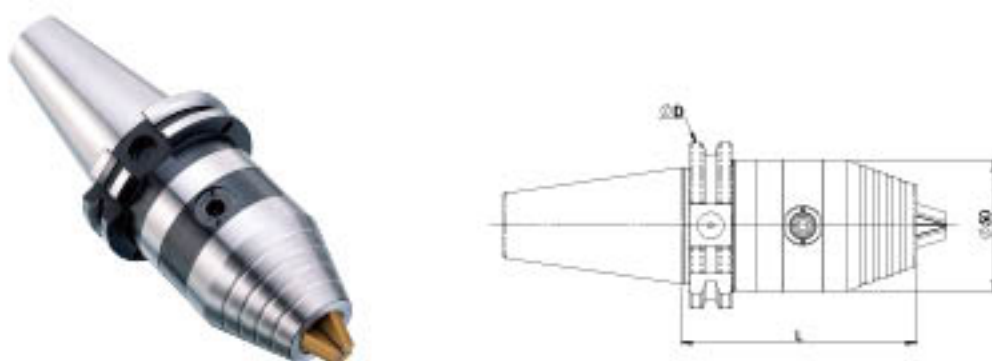

Code No. 型號	TYPE 規格	夾持範圍 Capacity		L	øD	Spanner No. 扳手規格	Weight (g) 重量
		mm.	Inch				
BA2SK40223201A	SK40xGHK13S-90	1-13	3/64-1/2	90	63.55	BESTC0008	1810
BA2SK40224201A	SK40xGHK16S-95	2.5-16	3/32-5/8	95	63.55		1830
BA2SK50223201A	SK50xGHK13S-90	1-13	3/64-1/2	90	97.5		3390
BA2SK50224201A	SK50xGHK16S-95	2.5-16	3/32-5/8	95	97.5		3280

* Custom-built products are available on request.

HSK Hex Key Drill Chuck (DIN69893)

HSK齒輪式夾頭

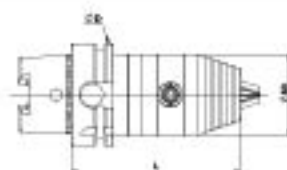

Code No. 型號	TYPE 規格	夾持範圍 Capacity		L	ϕD	Spanner No. 扳手規格	Weight (g) 重量
		mm	inch				
BA2HK63223201A	HSK63A×GHK13S-105	1-13	3/64-1/2	105	63	BESTC0008	1800
BA2HK63224201A	HSK63A×GHK16S-110	2.5-16	3/32-5/8	110			

* Custom-built products are available on request

VDI Hex Key Drill Chuck (DIN 69880-1)

VDI齒輪式夾頭

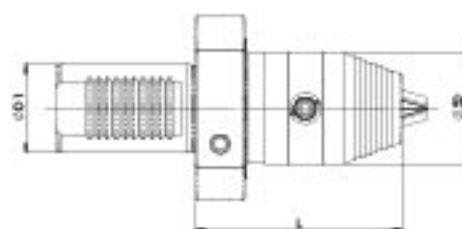

Code No. 型號	TYPE 規格	夾持範圍 Capacity		L	ϕD	h	ϕC	Spanner No. 扳手規格	Weight (g) 重量
		mm	inch						
BA2VD30223201A	VDI30×GHK13S-93	1-13	3/64-1/2	93	68	28	30	BESTC0008	1790
BA2VD30224201A	VDI30×GHK16S-98	2.5-16	3/32-1/2	98	68	28	30		1760
BA2VD40223201A	VDI40×GHK13S-93	1-13	3/64-1/2	93	83	32	40		2500
BA2VD40224201A	VDI40×GHK16S-98	2.5-16	3/32-5/8	98	83	32	40		2500

* Custom-built products are available on request

VDI Hex Key Drill Chuck (with spray nozzles)

VDI噴水頭型

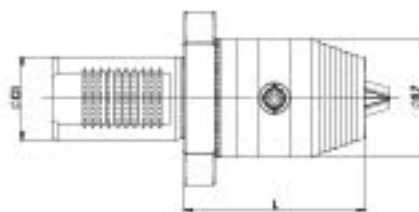
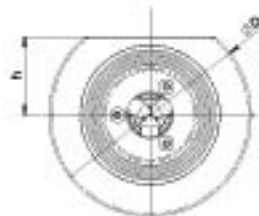

Code No. 型號	TYPE 規格	夾持範圍 Capacity		L	ϕD	h	ϕC	Spanner No. 扳手規格	Weight (g) 重量
		mm	inch						
BA2VD302231N2A	VDI30×GHK13S-87L	1-13	3/64-1/2	87	68	28	30	BESTC0008	
BA2VD302241N2A	VDI30×GHK16S-92L	2.5-16	3/32-5/8	92	68	28	30		
BA2VD402231N2A	VDI40×GHK13S-87L	1-13	3/64-1/2	87	83	32	40		
BA2VD402241N2A	VDI40×GHK16S-92L	2.5-16	3/32-5/8	92	83	32	40		

CAT Hex Key Drill Chuck

齒輪夾頭刀桿

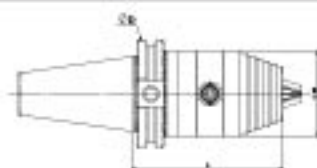

Code No. 型號	TYPE 規格	夾持範圍 Capacity		L	ØD	Spinner No. 型號編號
		mm	inch			
BA2CT40223202A	CAT40xGHK13S-90L	1-13	3/64-1/2	90	63.5	BESTC0006
BA2CT40224202A	CAT40xGHK16S-95L	2.5-16	3/32-5/8	95	63.5	
BA2CT50223202A	CAT50xGHK13S-90L	1-13	3/64-1/2	90	98.425	
BA2CT50224202A	CAT50xGHK16S-95L	2.5-16	3/32-5/8	95	98.425	

HEX KEY DRILL CHUCK Arbor Type

MT (Morse Taper)



Application / 產品適用

- Arbor structure makes its performance perfect for drilling press and machine center.
- Fine components ensure the tolerance and accuracy well.
- The benefit of titanium jaws is to increase the intensity and wear-resistance.

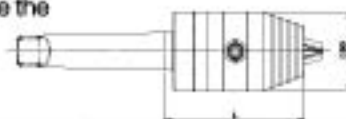

Code No. 型號	TYPE 規格	夾持範圍 Capacity		L	Spinner No. 型號編號	Weight (g) 重量
		mm	inch			
BA2MT02223201A	MT2xGHK13S-88	1-13	3/64-1/2	88	BESTC0008	1330
BA2MT02224201A	MT2xGHK16S-93	2.5-16	3/32-5/8	93		1390
BA2MT03223201A	MT3xGHK13S-88	1-13	3/64-1/2	88		1380
BA2MT03224201A	MT3xGHK16S-93	2.5-16	3/32-5/8	93		1360
BA2MT04223201A	MT4xGHK13S-89	1-13	3/64-1/2	89		1600
BA2MT04224201A	MT4xGHK16S-94	2.5-16	3/32-5/8	94		1830

* Custom-built products are available on request.

HEX KEY DRILL CHUCK Arbor Type (DIN1835_B)

D(Straight Shank)



Application / 產品適用

- Arbor structure makes its performance perfect for drilling press and machine center.
- Fine components ensure the tolerance and accuracy well.
- The benefit of titanium jaws is to increase the intensity and wear-resistance.

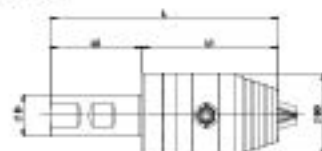

Code No. 型號	TYPE 規格	夾持範圍 Capacity		L	L2	L1	ØD	Spinner No. 型號編號	Weight (g) 重量
		mm	inch						
BA2DD020223201A	D20BxGHK13S-83	1-13	3/64-1/2	133	83	50	20	BESTC0008	1230
BA2DD020224201A	D20BxGHK16S-88	2.5-16	3/32-5/8	138	88	50	20		1240
BA2DD025223201A	D25BxGHK13S-83	1-13	3/64-1/2	139	83	56	25		
BA2DD025224201A	D25BxGHK16S-88	2.5-16	3/32-5/8	144	88	56	25		
BA2DD032223201A	D32BxGHK13S-83	1-13	3/64-1/2	143	83	60	32		
BA2DD032224201A	D32BxGHK16S-88	2.5-16	3/32-5/8	148	88	60	32		

* Custom-built products are available on request.

Coolant Pipe

冷卻導管

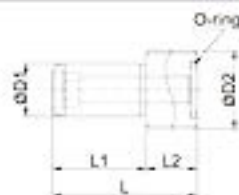

Code No. 型號	HSK NO.	$\phi D1$	$\phi D2$	L	L1	L2	O-ring
BE846H101A	HSK32	6	M10x1.0	26	20.5	5.5	P4
BE846H201A	HSK40	8	M12x1.0	29.5	22	7.5	P6
BE846H301A	HSK50	10	M16x1.0	33	23.5	9.5	P9
BE846H401A	HSK63	12	M18x1.0	36.5	25	11.5	P11
BE846H501A	HSK80	14	M20x1.5	40	25.5	13.5	P12
BE846H601A	HSK100	16	M24x1.5	44	28.5	15.5	P15

BT/Coolant Thru-Hole Models

BT水孔型

Pull Stud 拉栓

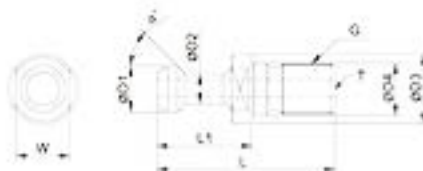

Code No. 型號	Type 規格 BT-d°	T	W	L	L1	$\phi D1$	$\phi D2$	$\phi D3$	$\phi D4$	G
BE812BW04A	BT40-45°	$\phi 4$	19	60	35	15	10	23	17	M16
BE812BW05A	BT40-60°	$\phi 4$								
BE812BW06A	BT40-90°	$\phi 4$								
BE812BW07A	BT50-45°	$\phi 7$	30	85	45	23	17	38	25	M24
BE812BW08A	BT50-60°	$\phi 7$								
BE812BW09A	BT50-90°	$\phi 7$								

BT/Threading Ground Models

BT磨牙型

Pull Stud 拉栓

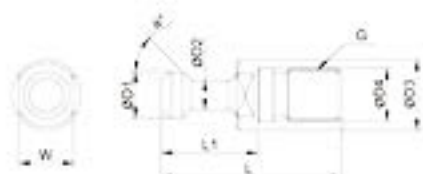

Code No. 型號	Type 規格 BT-d°	W	L	L1	$\phi D1$	$\phi D2$	$\phi D3$	$\phi D4$	$\phi D4$
BE812BG01A	BT30-45°G	13	43	23	11	7	16.5	12.5	M12
BE812BG04A	BT40-45°G	19	60	35	15	10	23	17	M16
BE812BG07A	BT50-45°G	30	85	45	23	17	38	25	M24
BE812BG02A	BT30-60°G	13	43	23	11	7	16.5	12.5	M12
BE812BG05A	BT40-60°G	19	60	35	15	10	23	17	M16
BE812BG08A	BT50-60°G	30	85	45	23	17	38	25	M24
BE812BG03A	BT30-90°G	13	43	23	11	7	16.5	12.5	M12
BE812BG06A	BT40-90°G	19	60	35	15	10	23	17	M16
BE812BG09A	BT50-90°G	30	85	45	23	17	38	25	M24

DIN A Type
DIN A型

Pull Stud 拉栓



Code No. 型號	Type 規格	W	L	L1	$\phi C1$	$\phi C2$	$\phi C3$	$\phi C4$	$\phi C5$	ϕ
BE812DA01A	DIN 30A	14	44	24	13	9	17	13	-	M12
BE812DA02A	DIN 40A	19	54	26	19	14	23	17	7	M16
BE812DA03A	DIN 40-A-L	19	54	29	19	14	23	17	7	M16
BE812DA04A	DIN 50A	30	74	34	28	21	36	25	11.5	M24

DIN B Type
DIN B型

Pull Stud 拉栓



Code No. 型號	Type 規格	W	L	L1	$\phi C1$	$\phi C2$	$\phi C3$	$\phi C4$	$\phi C5$	ϕ
BE812DB01A	DIN 30B	14	44	24	13	9	17	13	-	M12
BE812DB02A	DIN 40B	19	54	26	19	14	23	17	7	M16
BE812DB03A	DIN 50B	30	74	34	28	21	36	25	11.5	M24

DIN / R Type
DIN R型

Pull Stud 拉栓

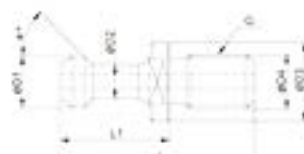

Code No. 型號	Type 規格	D	d1	d2	d3	d4	L	L1	L2	SW	F
BE812DR01A	DIN 40-R	23	14	19	17	7	54	29	23	19	M16*2.0

ISO A Type / ISO B Type

ISO A型 / ISO B型

Pull Stud 拉栓



Code No. 型號	Type 規格	W	L	L1	$\phi D1$	$\phi D2$	$\phi D3$	$\phi D4$	ϕD	Q
BE812SA01A	ISO 40-A	19	54	26	19	14	23	17	7	M16
BE812SA02A	ISO 50-A	30	74	34	28	21	36	25	11.5	M24
BE812SB01A	ISO 40-B	19	44.5	16.4	18.8	12.95	22.5	17	7.3	M16
BE812SB02A	ISO 50-B	30	65.5	25.5	29.1	19.6	37	25	11.5	M24

CAT Standard Models

CAT標準型

Pull Stud 拉栓

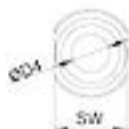

Code No. 型號	Type 規格	SW	L	L1	$\phi D1$	$\phi D2$	$\phi D3$	$\phi D4$	Q
BE812CT01A	CAT 40	0.75	1.5	0.64	0.74	0.49	0.94	0.281	5/8"-11
BE812CT02A	CAT 50	1.25	2.3	1	1.14	0.82	1.44	0.468	1"-8

BT(S) Power Type

強力型拉栓

Pull Stud 拉栓



-190° cryogenic.
treatment.
High hardness.
High tensile.

強力型拉栓
破層分布穩定
本產品經過 -190° 超冷處理
硬度增加 具有高拉力

Code No. 型號	Type 規格	D	d1	d2	d3	L	L1	L2	SW	P
BE815BS01A	BT30-45°S	16.5	7	11	12.5	43	23	18	13	M12*1.75
BE815BS02A	BT30-60°S	16.5	7	11	12.5	43	23	18	13	M12*1.75
BE815BS03A	BT40-45°S	23	10	15	17	60	35	28	19	M16*2.0
BE815BS04A	BT40-60°S	23	10	15	17	60	35	28	19	M16*2.0

*訂購數量 100pcs/箱

ER SPRING COLLET SYSTEM

彈性筒夾 DIN 6499

■ Application / 產品適用

- It is applied for a variety of processing including drilling, milling, tapping and grinding.
- 它適用於各種的加工，包含鑽孔，銑床，攻牙和研磨。

Toolholder not included

不含刀把

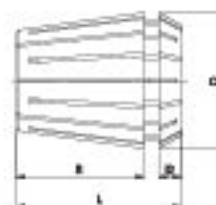

Code No. 型號	Type 規格	Collet 規格	D	L	n	l2
BE000100A	ER8x9	5, 4.5, 4, 3.5, 3, 2.5, 2, 1.5, 1	8.5	13.5	10.8	1.5
BE000200A	ER11x7	7, 6, 5, 4, 3, 2, 1	11.5	18	13.5	2.5
BE000300A	ER11x13	7, 6.5, 6, 5.5, 5, 4.5, 4, 3.5, 3, 2.5, 2, 1.5, 1				
BE000400A	ER16x8	10, 9, 8, 7, 6, 5, 4, 3	17	27	20.8	4
BE000500A	ER16x10	10, 9, 8, 7, 6, 5, 4, 3, 2, 1				
BE000600A	ER20x10	13, 12, 11, 10, 9, 8, 7, 6, 5, 4	21	31	23.9	4.8
BE000700A	ER20x12	13, 12, 11, 10, 9, 8, 7, 6, 5, 4, 3, 2				
BE000800A	ER25x7	13, 12, 11, 10, 9, 8, 7, 6, 5, 4, 3, 2	26	35	25.9	5
BE000900A	ER25x15	16, 15, 14, 13, 12, 11, 10, 9, 8, 7, 6, 5, 4, 3, 2				
BE001000A	ER32x6	20, 16, 12, 10, 8, 6	33	40	30.9	5.5
BE001100A	ER32x11	20, 18, 16, 15, 13, 12, 10, 8, 6, 5, 4				
BE001200A	ER32x18	20, 19, 18, 17, 16, 15, 14, 13, 12, 11, 10, 9, 8, 7, 6, 5, 4, 3	41	46	34.9	7
BE001300A	ER40x7	25, 20, 16, 12, 10, 8, 6				
BE001400A	ER40x15	26, 25, 22, 21, 20, 18, 16, 15, 13, 12, 10, 8, 6, 5, 4	52	60	46	8.5
BE001500A	ER40x23	26, 25, 24, 23, 22, 21, 20, 19, 18, 17, 16, 15, 14, 13, 12, 11, 10, 9, 8, 7, 6, 5, 4				
BE001600A	ER50x12	34, 32, 30, 28, 26, 24, 22, 20, 18, 16, 14, 12				

ER SPRING COLLET SYSTEM

彈性筒夾 DIN 6499

■ Application / 產品適用

- It is applied for a variety of processing including drilling, milling, tapping and grinding.
- 它適用於各種的加工，包含鑽孔，銑床，攻牙和研磨。

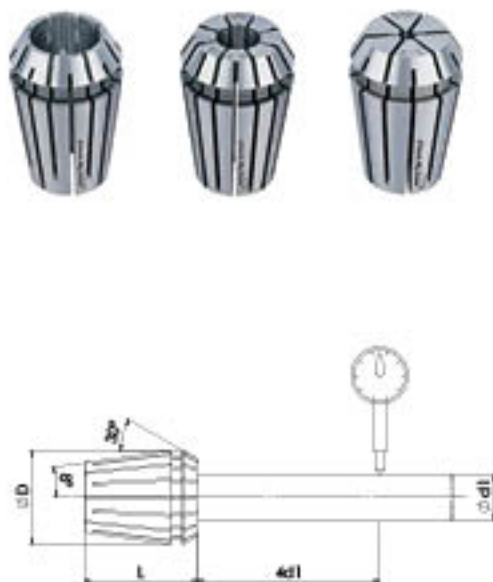

Type	ϕD	L
ER08	8.5	13.5
ER11	11.5	18
ER14	17	27
ER20	21	31
ER25	26	35
ER32	33	40
ER40	41	46
ER50	52	60

Code No. 型號	Type 規格	Code No. 型號	Type 規格
BE8000101A	ER8 [1.0-0.5]	BE8000701A	ER20[1.0-0.5]
BE8000102A	ER8 [1.5-1.0]	BE8000702A	ER20[0.5-1.0]
BE8000103A	ER8 [2.0-1.5]	BE8000703A	ER20[2.0-1.5]
BE8000104A	ER8 [2.5-2.0]	BE8000704A	ER20[2.5-2.0]
BE8000105A	ER8 [3.0-2.5]	BE8000705A	ER20[3.0-2.5]
BE8000106A	ER8 [3.5-3.0]	BE8000706A	ER20[3.5-3.0]
BE8000107A	ER8 [4.0-3.5]	BE8000707A	ER20[4.0-3.5]
BE8000108A	ER8 [4.5-4.0]	BE8000708A	ER20[4.5-4.0]
BE8000109A	ER8 [5.0-4.5]	BE8000709A	ER20[5.0-4.5]
BE8000301A	ER11 [1.0-0.5]	BE8000710A	ER20[5.5-5.0]
BE8000302A	ER11 [1.5-1.0]	BE8000711A	ER20[6.0-5.5]
BE8000303A	ER11 [2.0-1.5]	BE8000712A	ER20[6.5-6.0]
BE8000304A	ER11 [2.5-2.0]	BE8000713A	ER20[7.0-6.5]
BE8000305A	ER11 [3.0-2.5]	BE8000714A	ER20[7.5-7.0]
BE8000306A	ER11 [3.5-3.0]	BE8000715A	ER20[8.0-7.5]
BE8000307A	ER11 [4.0-3.5]	BE8000716A	ER20[8.5-8.0]
BE8000308A	ER11 [4.5-4.0]	BE8000717A	ER20[9.0-8.5]
BE8000309A	ER11 [5.0-4.5]	BE8000718A	ER20[9.5-9.0]
BE8000310A	ER11 [5.5-5.0]	BE8000719A	ER20[10-9.5]
BE8000311A	ER11 [6.0-5.5]	BE8000720A	ER20[10.5-10]
BE8000312A	ER11 [6.5-6.0]	BE8000721A	ER20[11-10.5]
BE8000313A	ER11 [7.0-6.5]	BE8000722A	ER20[11.5-11]
BE8000501A	ER16 [1.0-0.5]	BE8000723A	ER20[12-11.5]
BE8000502A	ER16 [1.5-1.0]	BE8000724A	ER20[12.5-12]
BE8000503A	ER16 [2.0-1.5]	BE8000725A	ER20[13-12.5]
BE8000504A	ER16 [2.5-2.0]	BE8000903A	ER25[2.0-1.0]
BE8000505A	ER16 [3.0-2.5]	BE8000904A	ER25[3.0-2.0]
BE8000506A	ER16 [3.5-3.0]	BE8000905A	ER25[4.0-3.0]
BE8000507A	ER16 [4.0-3.5]	BE8000906A	ER25[5.0-4.0]
BE8000508A	ER16 [4.5-4.0]	BE8000907A	ER25[6.0-5.0]
BE8000509A	ER16 [5.0-4.5]	BE8000908A	ER25[7.0-6.0]
BE8000510A	ER16 [5.5-5.0]	BE8000909A	ER25[8.0-7.0]
BE8000511A	ER16 [6.0-5.5]	BE8000910A	ER25[9.0-8.0]
BE8000512A	ER16 [6.5-6.0]	BE8000911A	ER25[10-9.0]
BE8000513A	ER16 [7.0-6.5]	BE8000912A	ER25[11-10]
BE8000514A	ER16 [7.5-7.0]	BE8000913A	ER25[12-11]
BE8000515A	ER16 [8.0-7.5]	BE8000914A	ER25[13-12]
BE8000516A	ER16 [8.5-8.0]	BE8000915A	ER25[14-13]
BE8000517A	ER16 [9.0-8.5]	BE8000916A	ER25[15-14]
BE8000518A	ER16 [9.5-9.0]	BE8000917A	ER25[16-15]
BE8000519A	ER16 [10.0-9.5]		

ER SPRING COLLET SYSTEM

彈性筒夾 DIN 6499

■ Application / 產品適用

- It is applied for a variety of processing including drilling, milling, tapping, mill.
- 它適用於各種的加工，包含鑽孔，銑床，攻牙和銑刀。

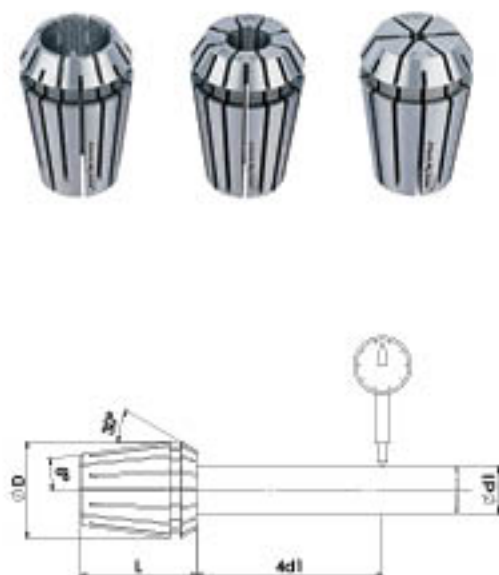

Type	∅D	L
ER08	8.5	13.5
ER11	11.5	18
ER16	17	27
ER20	21	31
ER25	26	35
ER32	33	40
ER40	41	46
ER50	52	60

Code No. 型號	Type 規格
BE8001101A	ER32 [2.0-1.0]
BE8001102A	ER32 [3.0-2.0]
BE8001103A	ER32 [4.0-3.0]
BE8001104A	ER32 [5.0-4.0]
BE8001105A	ER32 [6.0-5.0]
BE8001106A	ER32 [7.0-6.0]
BE8001107A	ER32 [8.0-7.0]
BE8001108A	ER32 [9.0-8.0]
BE8001109A	ER32 [10-9.0]
BE8001110A	ER32 [11-10]
BE8001111A	ER32 [12-11]
BE8001112A	ER32 [13-12]
BE8001113A	ER32 [14-13]
BE8001114A	ER32 [15-14]
BE8001115A	ER32 [16-15]
BE8001116A	ER32 [17-16]
BE8001117A	ER32 [18-17]
BE8001118A	ER32 [19-18]
BE8001119A	ER32 [20-19]

Code No. 型號	Type 規格
BE8001301A	ER40 [3.0-2.0]
BE8001302A	ER40 [4.0-3.0]
BE8001303A	ER40 [5.0-4.0]
BE8001304A	ER40 [6.0-5.0]
BE8001305A	ER40 [7.0-6.0]
BE8001306A	ER40 [8.0-7.0]
BE8001307A	ER40 [9.0-8.0]
BE8001308A	ER40 [10-9.0]
BE8001309A	ER40 [11-10]
BE8001310A	ER40 [12-11]
BE8001311A	ER40 [13-12]
BE8001312A	ER40 [14-13]
BE8001313A	ER40 [15-14]
BE8001314A	ER40 [16-15]
BE8001315A	ER40 [17-16]
BE8001316A	ER40 [18-17]
BE8001317A	ER40 [19-18]
BE8001318A	ER40 [20-19]
BE8001319A	ER40 [21-20]
BE8001320A	ER40 [22-21]
BE8001321A	ER40 [23-22]
BE8001322A	ER40 [24-23]
BE8001323A	ER40 [25-24]
BE8001324A	ER40 [26-25]
BE8001507A	ER50 [12-10]
BE8001508A	ER50 [14-12]
BE8001509A	ER50 [16-14]
BE8001510A	ER50 [18-16]
BE8001511A	ER50 [20-18]
BE8001512A	ER50 [22-20]
BE8001513A	ER50 [24-22]
BE8001514A	ER50 [26-24]
BE8001515A	ER50 [28-26]
BE8001516A	ER50 [30-28]
BE8001517A	ER50 [32-30]
BE8001518A	ER50 [34-32]

SK SPRING COLLET SYSTEM

彈性筒夾 DIN 6499

■ Application / 產品適用

- It is applied for a variety of processing including drilling, milling, tapping and grinding.
- 它適用於各種的加工，包含鑽孔，銑床，攻牙和研磨。



Type	∅D	L
SK06	10.5	25
SK10	15.5	30.5
SK13	20	39
SK16	24.5	45
SK20	28.5	54
SK25	35.5	57



SK6			
Code No.	Type	∅d	FW/DL
BE8102101A	SK6	2	2-1.75
BE8102102A		2.5	2.5-2.25
BE8102103A		3	3-2.75
BE8102104A		3.5	3.5-3
BE8102105A		4	4-3.5
BE8102106A		4.5	4.5-4
BE8102107A		5	5-4.5
BE8102108A		5.5	5.5-5
BE8102109A		6	6-5.5

SK25			
Code No.	Type	∅d	FW/DL
BE8103101A	SK25	6	6-5.5
BE8103103A		8	8-7.5
BE8103105A		10	10-9.5
BE8103107A		12	12-11.5
BE8103109A		14	14-13.4
BE8103111A		16	16-15.5
BE8103113A		18	18-17.5
BE8103115A		20	20-19.5
BE8103117A		22	22-21.5
BE8103119A		24	24-23.5
BE8103120A		25	25-24.5
BE8103121A		25.4	25.4-25

SK20			
Code No.	Type	∅d	FW/DL
BE8102901A	SK20	3	3-2.75
BE8102902A		4	4-3.5
BE8102903A		5	5-4.5
BE8102904A		6	6-5.5
BE8102905A		6.5	6.5-6
BE8102906A		7	7-6.5
BE8102907A		7.5	7.5-7
BE8102908A		8	8-7.5
BE8102909A		8.5	8.5-8
BE8102910A		9	9-8.5
BE8102911A		9.5	9.5-9
BE8102912A		10	10-9.5
BE8102913A		10.5	10.5-10
BE8102914A		11	11-10.5
BE8102915A		11.5	11.5-11
BE8102916A		12	12-11.5
BE8102917A		12.5	12.5-12
BE8102918A		13	13-12.5
BE8102919A		13.5	13.5-13
BE8102920A		14	14-13.5
BE8102921A	14.5	14.5-14	
BE8102922A	15	15-14.5	
BE8102923A	15.5	15.5-15	
BE8102924A	16	16-15.5	
BE8102925A	16.5	16.5-16	
BE8102926A	17	17-16.5	
BE8102927A	17.5	17.5-17	
BE8102928A	18	18-17.5	
BE8102929A	18.5	18.5-18	
BE8102930A	19	19-18.5	
BE8102931A	19.5	19.5-19	
BE8102932A	20	20-19.5	

SK16			
Code No.	Type	∅d	FW/DL
BE8102501A	SK16	3	3-2.75
BE8102502A		3.5	3.5-3
BE8102503A		4	4-3.5
BE8102504A		4.5	4.5-4
BE8102505A		5	5-4.5
BE8102506A		5.5	5.5-5
BE8102507A		6	6-5.5
BE8102508A		6.5	6.5-6
BE8102509A		7	7-6.5
BE8102510A		7.5	7.5-7
BE8102511A		8	8-7.5
BE8102512A		8.5	8.5-8
BE8102513A		9	9-8.5
BE8102514A		9.5	9.5-9
BE8102515A		10	10-9.5
BE8102516A		10.5	10.5-10
BE8102517A	11	11-10.5	
BE8102518A	11.5	11.5-11	
BE8102519A	12	12-11.5	
BE8102520A	12.5	12.5-12	
BE8102521A	13	13-12.5	
BE8102522A	13.5	13.5-13	
BE8102523A	14	14-13.5	
BE8102524A	14.5	14.5-14	
BE8102525A	15	15-14.5	
BE8102526A	15.5	15.5-15	
BE8102527A	16	16-15.5	

SK10			
Code No.	Type	∅d	FW/DL
BE8102301A	SK10	2	2-1.75
BE8102302A		2.5	2.5-2.25
BE8102303A		3	3-2.75
BE8102304A		3.5	3.5-3
BE8102305A		4	4-3.5
BE8102306A		4.5	4.5-4
BE8102307A		5	5-4.5
BE8102308A		5.5	5.5-5
BE8102309A		6	6-5.5
BE8102310A		6.5	6.5-6
BE8102311A		7	7-6.5
BE8102312A		7.5	7.5-7
BE8102313A		8	8-7.5
BE8102314A		8.5	8.5-8
BE8102315A	9	9-8.5	
BE8102316A	9.5	9.5-9	
BE8102317A	10	10-9.5	

STRAIGHT COLLET

直筒式彈性筒夾

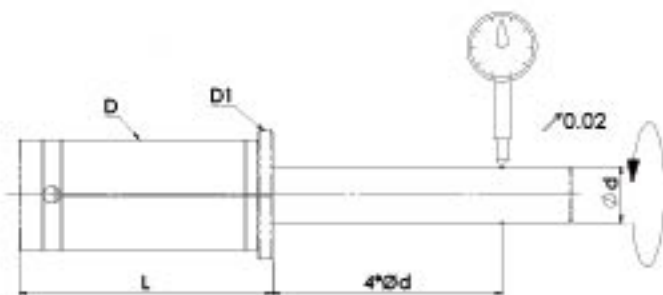

Code No. 型號	Type 規格	d1	L	D	DI
BE8004301A	C20	3	52	20	25
BE8004302A		4			
BE8004303A		5			
BE8004304A		6			
BE8004305A		7			
BE8004306A		8			
BE8004307A		9			
BE8004308A		10			
BE8004309A		11			
BE8004310A		12			
BE8004311A		13			
BE8004312A		14			
BE8004313A		15			
BE8004314A		16			

Code No. 型號	Type 規格	d1	L	D	d1
BE8004501A	C25	4	60	25	31
BE8004502A		5			
BE8004503A		6			
BE8004505A		8			
BE8004506A		9			
BE8004507A		10			
BE8004508A		11			
BE8004509A		12			
BE8004517A		13			
BE8004510A		14			
BE8004511A		15			
BE8004512A		16			
BE8004513A		17			
BE8004514A		18			
BE8004515A	19				
BE8004516A	20				

* 公制 → 公制 | 公制 → 英制 | 英制 → 英制 · 請客戶需求

STRAIGHT COLLET

直筒式彈性筒夾

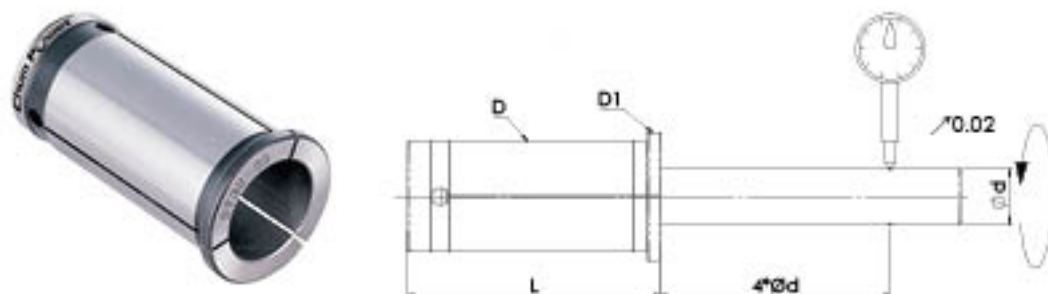

Code No. 型號	Type 規格	d1	L	D	d
BE8004701A	C32	3	73	32	37
BE8004702A		4			
BE8004703A		5			
BE8004704A		6			
BE8004705A		7			
BE8004706A		8			
BE8004707A		9			
BE8004708A		10			
BE8004709A		11			
BE8004710A		12			
BE8004711A		13			
BE8004712A		14			
BE8004713A		15			
BE8004714A		16			
BE8004715A		17			
BE8004716A		18			
BE8004717A		19			
BE8004718A		20			
BE8004719A		21			
BE8004720A		22			
BE8004723A		25			

Code No. 型號	Type 規格	d1	L	D	d
BE8004901A	C42	6	78	42	48
BE8004902A		8			
BE8004903A		10			
BE8004904A		12			
BE8004905A		14			
BE8004906A		16			
BE8004907A		18			
BE8004908A		20			
BE8004909A		22			
BE8004910A		25			
BE8004911A		32			

Z Axial Preset Gauge

Z軸設定器

- For setting length on machining centers/lathe centers.
- Setting height: $50.00 \pm 0.005\text{mm}$.
- Large measuring surface and easy to operate.
 - Low spring force, May avoid the milling cutter or the drill bit breaking.
 - Easy to be calibrated by a ground parallel or gauge block.
 - Better parallelism, sensitivit, and precision for use.
 - 在電腦銑床 / 車床上設定刀長用。
 - 設計高度： $50,00 \pm 0.005\text{mm}$ 。
 - 量側面大，操作容易。
 - 彈簧力較小，可避免小銑刀或鑽頭斷裂。
 - 用研磨過的平行板，即可簡單設定。
 - 平行度及各方面使用靈敏，且精度更好。

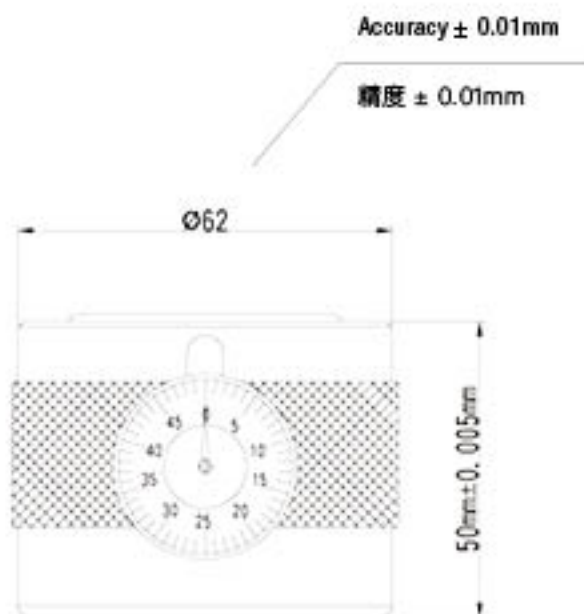

Code No. 型號	Type 規格	Height 高度 (mm)	G/W Weight 重量 (G)	LxWxH	Magnetism 磁性
BTAPG845501A	ZH-50A	50.00±0.005	1.2	50×63×63	0

Tool Locking Device

鎖刀座

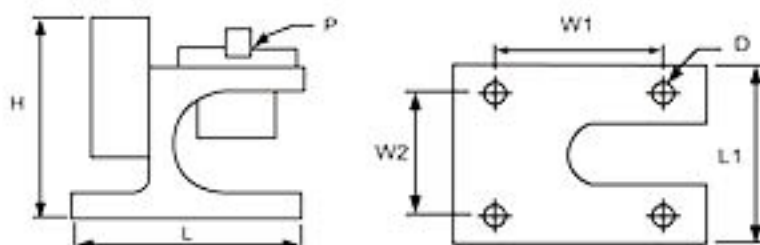

Code No. 型號	TYPE 規格	P	L	L1	H	W1	W2	D	Wgt. 重量(kg)
BTTLD845101A	BT30	BT	145	103	143	112	72	13	4.2
BTTLD845102A	BT40	BT	145	103	143	112	72	13	4.2
BTTLD845103A	BT50	BT	177	135	205	140	100	13	7.6

Tool Locking Device A Type (Cast Iron Body)

鎖刀座 A型(主體為鑄鐵)

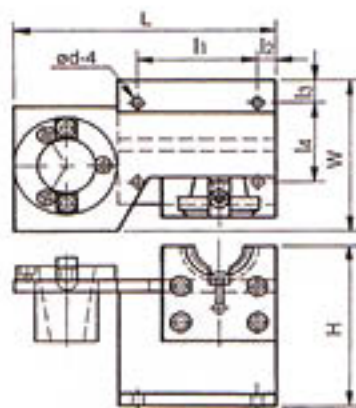

Code No. 型號	TYPE 規格	L	l1	l2	b1	b2	H	H	W	H.W. 淨重(kg)	G.W. 毛重(kg)	Shipped Size 裝箱尺寸(mm)
BTTLD845151A	CP-BT30A	210	95	10	15	67	130	100	3.6	3.7	22x11.5x14	
BTTLD845152A	CP-BT40A	210	95	10	15	67	130	100	3.7	3.9	22x11.5x14	
BTTLD845153A	CP-BT50A	275	113	20	24	105	200	150	11	11.4	29.5x17x21	
BTTLD845154A	CP-DIN40A	210	95	10	15	67	130	100	3.6	3.8	22x11.5x14	
BTTLD845155A	CP-DIN50A	275	113	20	24	105	200	150	10.8	11.2	29.5x17x21	
BTTLD845156A	CP-CAT40A	210	95	10	15	67	130	100	3.6	3.8	22x11.5x14	
BTTLD845157A	CP-CAT50A	275	113	20	24	105	200	150	10.8	11.2	29.5x17x21	

Taper Wiper BT Type

清潔棒 BT型

- Cleaning chips of taper wiper is made of lambskin.
- It can clean inside sides of spindles to prevent static electricity and to extend the longevity of spindles and tapers.
- 清潔棒的清潔片由小羊皮製成，可清理主軸內部，不傷主軸，防止靜電產生，延長主軸使用壽命。



Code No. 型號	TYPE 規格	Taper 直徑	H.W. 淨重 (g)	G.W. 毛重 (g)	Shipment Size 裝箱尺寸 (cm)	Pieces/Box/Ctn 每箱(支/箱)
BTSTT000101A	W-30	#30	0.06	0.08	41x29.5x20	30
BTSTT000102A	W-40	#40	0.07	0.10	41x29.5x20	30
BTSTT000103A	W-50	#50	0.16	0.20	41x29.5x20	10
BTSTT000104A	W-30P	#30	0.06	0.08	41x29.5x20	30
BTSTT000105A	W-40P	#40	0.07	0.10	41x29.5x20	30
BTSTT000106A	W-50P	#50	0.16	0.20	41x29.5x20	10

Taper Wiper HSK Type

清潔棒 HSK型

- Cleaning chips of taper wiper is made of lambskin.
- It can clean inside sides of spindles to prevent static electricity and to extend the longevity of spindles and tapers.
- 清潔棒的清潔片由小羊皮製成，可清理主軸內部，不傷主軸，防止靜電產生，延長主軸使用壽命。



Code No. 型號	TYPE 規格	Model No. 型號	H.W. 淨重 (g)	G.W. 毛重 (g)	Shipment Size 裝箱尺寸 (cm)	Pieces/Box/Ctn 每箱(支/箱)
BTSTT000201A	W-HSK40A	HSK40	0.08	0.10	41x29.5x20	30
BTSTT000202A	W-HSK50H	HSK50/HSK63F	0.08	0.12	41x29.5x20	10
BTSTT000203A	W-HSK63H	HSK63/HSK80F	0.10	0.13	41x29.5x20	10
BTSTT000204A	W-HSK100H	HSK100	0.54	0.7	41x29.5x20	3

H Type

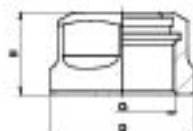

ER Hx

Code No. 型號	Spec. 規格	H	D	SW	Ø	Spanner No. 扳手編號
BB200ER11A001A	ER 11-H	11.5	19	17	M14xP0.75	BA2ER11020001A
BB200ER16A001A	ER 16-H	17.5	28	25	M22xP1.5	BA2ER16020001A
BB200ER20A001A	ER 20-H	19	34	30	M25xP1.5	BA2ER20020001A

B Type

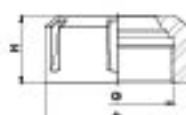

ER B

Code No. 型號	Spec. 規格	H	D	Ø	Spanner No. 扳手編號
BB200ER25B001A	ER 25-B	20	42	M32xP1.5	BA2ER25100001A
BB200ER32B001A	ER 32-B	24	50	M40xP1.5	BA2ER32100001A
BB200ER40B001A	ER 40-B	25	63	M50xP1.5	BA2ER40100001A
BB200ER50B001A	ER 50-B	35	78	M64xP2.0	BA2ER50100001A

S Type

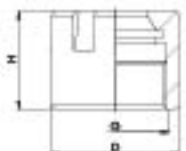

ER S

Code No. 型號	Spec. 規格	H	D	Ø	Spanner No. 扳手編號
BB200ER08S001A	ER 8-S	10.8	12	M10xP0.75	BE80SER08A
BB200ER11S001A	ER 11-S	12	16	M13xP0.75	BE80SER11A
BB200ER16S001A	ER 16-S	18	23	M19xP1.0	BE80SER16A
BB200ER20S001A	ER 20-S	19	28	M24xP1.0	BE80SER20A
BB200ER25S001A	ER 25-S	20	35	M30xP1.0	BE80SER25A



Code No. 型號	Spec. 規格	H	D	Ø	Spanner No. 扳手編號
BB200SK06D001A	SK 6	16.5	19.5	M15.5xP1.0	BE80DSK06A
BB200SK10D001A	SK10	20	30	M21.5xP1.0	BE80DSK10A
BB200SK16D001A	SK16	30	40	M32xP1.5	BE80DSK16A

Fig1



Fig2



Fig1

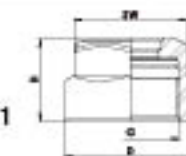
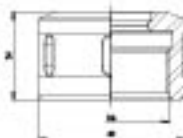

Fig2



Code No. 型號	Spec. 規格	H	D	SW	Ø	Type	Spanner No. 扳手編號
BB200SK06A001A	SK06	15	19.5	18	M15.5xP1.0	Fig1.	BA2SK06250001A
BB200SK10A001A	SK10	17	29	25	M21.5xP1.0	Fig1.	BA2SK10250001A
BB200SK10C001A	SK10	17	29		M21.5xP1.0	Fig2.	BA2SK10260001A
BB200SK13C001A	SK13	21	33		M27xP1.0	Fig2.	BA2SK13260001A
BB200SK16C001A	SK16	24	40		M32xP1.5	Fig2.	BA2SK16260001A
BB200SK20C001A	SK20	24	48.5		M40xP1.0	Fig2.	BA2SK20260001A
BB200SK25C001A	SK25	30	55		M45xP1.5	Fig2.	BA2SK25260001A

ER Spanner

ER板手



ER小徑板手 ER S

Code No. 型號	Spec. 規格	A	L
BE80SER08A	ER08S	13	75
BE80SER11A	ER11S	17	95
BE80SER16A	ER16S	22.5	118
BE80SER20A	ER20S	28	110
BE80SER25A	ER25S	36.5	135



開口板手 ER Hex

Code No. 型號	Spec. 規格	A	L
BA2ER11020001A	ER11H	17	130
BA2ER16020001A	ER16H	25	140
BA2ER20020001A	ER20H	30	170



ER標準板手 ER B

Code No. 型號	Spec. 規格	A	L
BA2ER25100001A	ER25B	65	210
BA2ER32100001A	ER32B	75	250
BA2ER40100001A	ER40B	90	290
BA2ER50100001A	ER50B	110	350

Hook Wrench

勾板手



Code No. 型號	Spec. 規格	A	L
BA20C20030001A	C20	-	202
BA20C25030001A	C25	-	232
BA20C32030001A	C32	-	272
BA20C42030001A	C42	-	338

Optical Edge Finder

光電式尋邊器

- Quickly locate work edges and save time to find positions for Milling , Lathe Machine, and other machines.
- The scope of application includes processing material edge, and measuring inside and outside diameters of work-piece efficiently.
 - There is a safety spring puller, which will put a ball precisely back to the position when ball breaks away from ball seat.
 - Attached 2 dry batteries to light the red lamp.
- 迅速的找出工作位置，對於銑床、車床、及其他機械設備，都能有效節省尋找位置所需時間。
- 可應用於加工件邊及內、外徑之高效率量測。
- 當鋼球脫離時，有一個安全彈簧可精確的將其拉回原來的 位置。
- 附 2 枚 1.5V 鹼性乾電池。

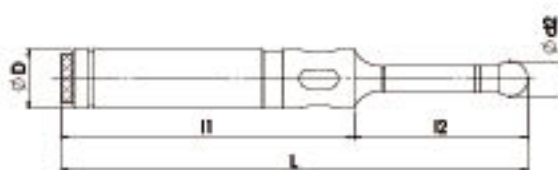

Code No. 型號	TYPE 口徑	d	L	l1	l2
BTLEF844301A	20	10	158	108	50
BTLEF844302A	32	10	158	108	50