

Angle Head

橫向銑頭

G



Feature

產品特色

- Customized setting blocks can be rasily installed without any mondification of machine construction.
- The body is made of Ductile Casr Iron with high tensile strength.
- Can be automatic tool changed. Save time; increase efficiency.
- Cutting direction can be adjusted from 0 to 360 degree. Can easily be set by indicating the datum face.
- Precision P4 Class bearing provides accurate concentricity.
- Low tenoerature rising, waterproof, oil-proof, and dust-proof.
- Avoids turning workpiece around to increase accuracy and productivity.
- Ideal for drilling, tapping, end milling, face milling and various machining applications.

- 定位塊安裝簡易，無需更改機台結構。
- 本體材質為球狀石墨鑄鐵，抗拉强度高。
- 可於刀庫自動換刀，節省時間，效率高。
- 可 360 度旋轉調整加工角度，可透過兩側研磨平行面，簡單校正加工方向。
- 使用 P4 級軸承，確保高精度。
- 溫升小、防水、防油級防塵。
- 減少翻動工件，提高加工工件精度及生產力。
- 多功能用途，適用鑽孔、攻牙、端銑、面銑 ... 等加工，加工適用範圍大。

Application 加工範例



Internal Machining
內面加工



Saw and Cutting
鉅切加工

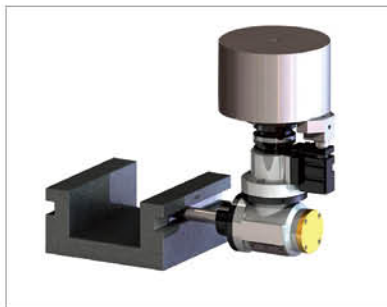

Side Machining
側面加工

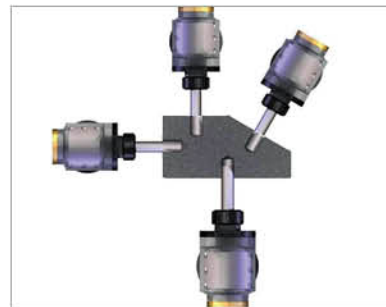

Any Angle Machining
任意角度加工



Curved Surface Machining
曲面加工



45 Degree Machining
45° 角加工

CPA Type

90°橫向銑頭 90°Angle Head-ER

- The body is made of Ductile Cast Iron. High strength steel; stable machining.
- Wide selections of tool shanks. The design of ER32, ER40, and FA25.4 heads ensures various applications.
- Can be automatic tool changed. Increases productivity.
- Suitable for light and middle cutting.
- 本體採用球狀石墨鑄鐵，剛性強，加工穩定。
- 適用主軸種類多樣化。夾持刀具種類、尺寸多樣化，ER32、ER40、FA25.4 型式，可涵蓋大部分加工應用。
- 自動刀庫換刀加工，量化生產必備工具。
- 適用中、輕切削。

內孔偏擺度	0.002 mm
材質	球狀石墨鑄鐵
轉速	最高 4000 RPM
扭力	最大 27Nm
齒輪比	1:0.81
適用主軸	BT, NT, SK(ISO), CAT
標準配件	鉤形扳手、ER 扳手、ER 螺帽
出力軸轉向	反轉

Run out	0.002 mm
Material	Ductile Cast Iron
R.P.M.	Max. 4000 RPM
Torque	Max. 27Nm
Gear Ratio	1:0.81
Spindle Type	BT, NT, SK(ISO), CAT
Standard Accessory	Hook Spanner ER Wrench, ER Nut
Output Rotation	Reverse to Input Rotation

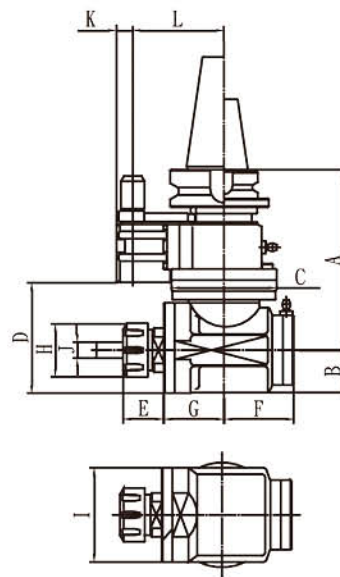

Code NO. 型號	TYPE 規格	A	B	C	D	E	F	G	H	I	J	K	L	N.W.(KG)
BTCPA0100010	BT40-ER32	160	40	98	103	39	65	56	50	88	3~20	15	65/80/85	7.8
BTCPA0100020	BT50-ER32	171	40	98	103	39	65	56	50	88	3~20	15	80/85/110	9.5
BTCPA0100030	BT40-ER40	160	40	98	103	44	65	56	63	88	4~26	15	65/80/85	7.8
BTCPA0100040	BT50-ER40	171	40	98	103	44	65	56	63	88	4~26	15	80/85/110	9.5
BTCPA0100050	NT50-ER32	171	40	98	103	39	65	56	50	88	3~20	15	80/85/110	9.5
BTCPA0100060	NT50-ER40	171	40	98	103	44	65	56	63	88	4~26	15	80/85/110	9.5
BTCPA0100070	SK40-ER32	160	40	98	103	39	65	56	50	88	3~20	15	65/80/85	7.8
BTCPA0100080	SK50-ER32	171	40	98	103	39	65	56	50	88	3~20	15	80/85/110	9.5
BTCPA0100090	SK40-ER40	160	40	98	103	44	65	56	63	88	4~26	15	65/80/85	7.8
BTCPA0100100	SK50-ER40	171	40	98	103	44	65	56	63	88	4~26	15	80/85/110	9.5
BTCPA0100110	CAT40-ER32	160	40	98	103	39	65	56	50	88	3~20	15	65/80/85	7.8
BTCPA0100120	CAT50-ER32	171	40	98	103	39	65	56	50	88	3~20	15	80/85/110	9.5
BTCPA0100130	CAT40-ER40	160	40	98	103	44	65	56	63	88	4~26	15	65/80/85	7.8
BTCPA0100140	CAT50-ER40	171	40	98	103	44	65	56	63	88	4~26	15	80/85/110	9.5

Unit/mm

CPA Type

90°橫向銑頭 90°Angle Head-FA

- The body is made of Ductile Cast Iron. High strength steel; stable machining.
- Wide selections of tool shanks. The design of ER32, ER40, and FA25.4 heads ensures various applications.
- Can be automatic tool changed. Increases productivity.
- Suitable for light and middle cutting.
- 本體採用球狀石墨鑄鐵，剛性強，加工穩定。
- 適用主軸種類多樣化。夾持刀具種類、尺寸多樣化，ER32、ER40、FA25.4 型式，可涵蓋大部分加工應用。
- 自動刀庫換刀加工，量化生產必備工具。
- 適用中、輕切削。

內孔偏滲度	0.002 mm
材質	球狀石墨鑄鐵
轉速	最高 4000 RPM
扭力	最大 27Nm
齒輪比	1:0.81
適用主軸	BT, NT, SK(ISO), CAT
標準配件	開口扳手
出力軸轉向	反轉

Run out	0.002 mm
Material	Ductile Cast Iron
R.P.M.	Max. 4000 RPM
Torque	Max. 27Nm
Gear Ra	1:0.81
Spindle Type	BT, NT, SK(ISO), CAT
Standard Accessory	Open End Wrench
Output Rotation	Reverse to Input Rotation

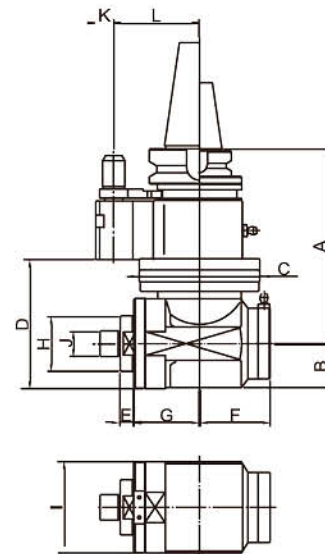

Code NO. 型號	TYPE 規格	A	B	C	D	E	F	G	H	I	J	K	L	N.W.(KG)
BTCPA0200010	BT40-FA25.4	160	40	98	103	12	65	56	50	88	25.4	15	65/80/85	7.8
BTCPA0200020	BT50-FA25.4	171	40	98	103	12	65	56	50	88	25.4	15	80/85/110	9.5
BTCPA0200030	NT50-FA25.4	171	40	98	103	12	65	56	50	88	25.4	15	80/85/110	9.5
BTCPA0200040	SK40-FA25.4	160	40	98	103	12	65	56	50	88	25.4	15	65/80/85	7.8
BTCPA0200050	SK50-FA25.4	171	40	98	103	12	65	56	50	88	25.4	15	80/85/110	9.5
BTCPA0200060	CAT40-FA25.4	160	40	98	103	12	65	56	50	88	25.4	15	65/80/85	7.8
BTCPA0200070	CAT50-FA25.4	171	40	98	103	12	65	56	50	88	25.4	15	80/85/110	9.5

Unit/mm

CPB Type

90°橫向銑頭 90°Angle Head-BT

- The body is made of Ductile Cast Iron, High strength steel; stable machining.
- The output interface of BT30 ensures wide-range application with various BT30 tool holders.
 - Can be automatic tool changed. Increases productivity.
 - 本體採用球狀石墨鑄鐵，剛性強，加工穩定。
 - BT30 刀具接合介面，提供各種 BT30 刀具之彈性應用，涵蓋大部分加工應用。
 - 自動刀庫換刀加工，量化生產必備工具。

內孔偏擺度	0.002 mm
材質	球狀石墨鑄鐵
轉速	最高 4000 RPM
扭力	最大 47Nm
齒輪比	1:1
適用主軸	BT, SK(ISO), CAT
標準配件	鉤形扳手、ER 扳手、ER 螺帽
出力軸轉向	反轉

Run out	0.002 mm
Material	Ductile Cast Iron
R.P.M.	Max. 4000 RPM
Torque	Max. 47Nm
Gear Ratio	1:1
Spindle Type	BT, SK(ISO), CAT
Standard Accessory	Hook Spanner Open End Wrench, BT Nut
Output Rotation	Reverse to Input Rotation

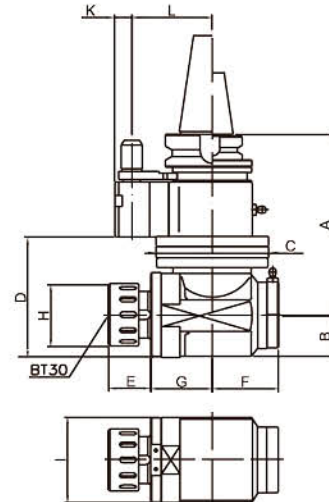

Code NO. 型號	TYPE 規格	A	B	C	D	E	F	G	H	I	K	L	Unit/mm N.W.(KG)
BTCPB0300010	BT40-BT30	192	44.5	120	127.5	45	70	65	66	90	17	70/80/85	12.1
BTCPB0300020	BT50-BT30	195	44.5	120	127.5	45	70	65	66	90	17	80/85/110	14.7
BTCPB0300030	SK40-BT30	192	44.5	120	127.5	45	70	65	66	90	17	70/80/85	12.1
BTCPB0300040	SK50-BT30	195	44.5	120	127.5	45	70	65	66	90	17	80/85/110	14.7
BTCPB0300050	CAT40-BT30	192	44.5	120	127.5	45	70	65	66	90	17	70/80/85	12.1
BTCPB0300060	CAT50-BT30	195	44.5	120	127.5	45	70	65	66	90	17	80/85/110	14.7

CPB Type

90°橫向銑頭 90°Angle Head-ER

- The body is made of Ductile Cast Iron, High strength steel; stable machining.
- Can be automatic tool changed. Increases productivity.
 - 本體採用球狀石墨鑄鐵，剛性強，加工穩定。
 - 自動刀庫換刀加工，量化生產必備工具。

內孔漏掃度	0.002 mm
材質	球狀石墨鑄鐵
轉速	最高 4000 RPM
扭力	最大 47Nm
齒輪比	1:1
適用主軸	BT, SK(ISO), CAT
標準配件	鉤形扳手、ER 扳手、ER 螺帽
出力軸轉向	反轉

Run out	0.002 mm
Material	Ductile Cast Iron
R.P.M.	Max. 4000 RPM
Torque	Max. 47Nm
Gear Ratio	1:1
Spindle Type	BT, SK(ISO), CAT
Standard Accessory	Hook Spanner ER Wrench, ER Nut
Output Rotation	Reverse to Input Rotation

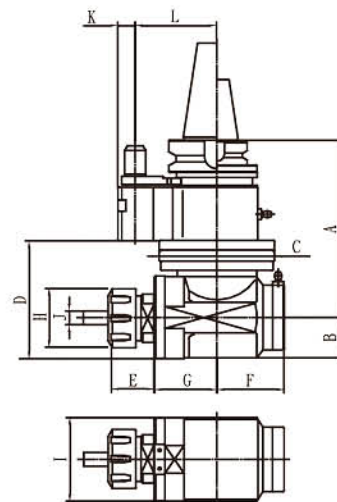

Code NO. 型號	TYPE 規格	A	B	C	D	E max	F	G	H	I	J	K	L	Unit/mm N.W.(KG)
BTCPB0100010	BT40-ER40	192	44.5	120	127.5	44	70	65	63	90	4~26	17	70/80/85	12.1
BTCPB0100020	BT50-ER40	195	44.5	120	127.5	44	70	65	63	90	4~26	17	80/85/110	14.7
BTCPB0100030	SK40-ER40	192	44.5	120	127.5	44	70	65	63	90	4~26	17	70/80/85	12.1
BTCPB0100040	SK50-ER40	195	44.5	120	127.5	44	70	65	63	90	4~26	17	80/85/110	14.7
BTCPB0100050	CAT40-ER40	192	44.5	120	127.5	44	70	65	63	90	4~26	17	70/80/85	12.1
BTCPB0100060	CAT50-ER40	195	44.5	120	127.5	44	70	65	63	90	4~26	17	80/85/110	14.7

CPC Type

90°橫向銑頭 90°Angle Head-FA

- The body is made of Ductile Cast Iron. High strength steel; stable machining.
- The AHC series is suitable for firm and fast face milling.
- Can be automatic tool changed. Increases productivity.
 - 本體採用球狀石墨鑄鐵，剛性強，加工穩定。
 - 面銑刀專用機種，直接連結面銑刀，加工穩定快速。
 - 自動刀庫換刀加工，量化生產必備工具。

內孔偏擺度	0.002 mm
材質	球狀石墨鑄鐵
轉速	最高 4000 RPM
扭力	最大 47 Nm
齒輪比	1:1
適用主軸	BT, SK(ISO), CAT
標準配件	開口 ER 扳手
出力軸轉向	反轉

Run-out	0.002 mm
Material	Ductile Cast Iron
R.P.M.	Max. 4000 RPM
Torque	Max. 47 Nm
Gear Ratio	1:1
Spindle Type	BT, SK(ISO), CAT
Standard Accessory	Open End Wrench
Output Rotation	Reverse to Input Rotation

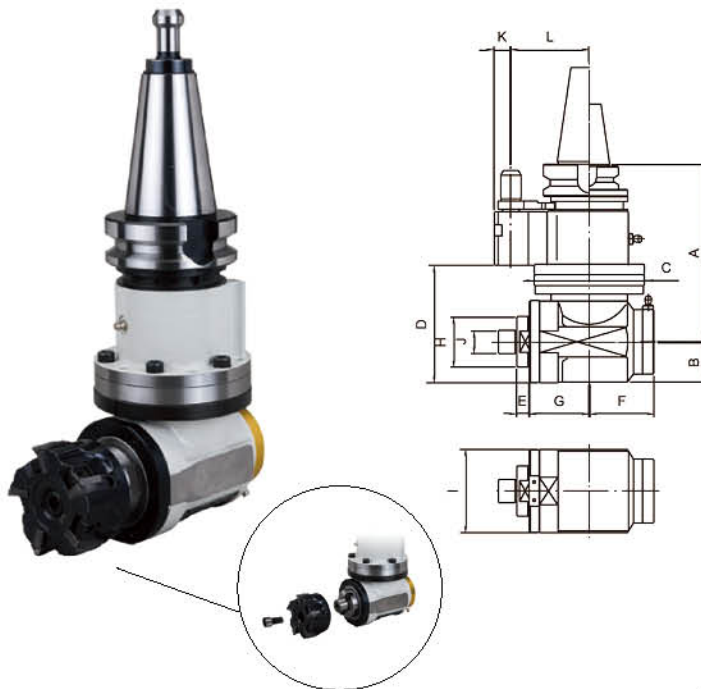

Code NO. 型號	TYPE 規格	A	B	C	D	E	F	G	H	I	J	K	L	Unit/mm N.W.(KG)
BTCP0200010	BT40-FA25.4	192	44.5	120	127.5	13.5	70	65	55	90	25.4	17	70/80/85	12.1
BTCP0200020	BT50-FA25.4	195	44.5	120	127.5	13.5	70	65	55	90	25.4	17	80/85/110	14.7
BTCP0200030	SK40-FA25.4	192	44.5	120	127.5	13.5	70	65	55	90	25.4	17	70/80/85	12.1
BTCP0200040	SK50-FA25.4	195	44.5	120	127.5	13.5	70	65	55	90	25.4	17	80/85/110	14.7
BTCP0200050	CAT40-FA25.4	192	44.5	120	127.5	13.5	70	65	55	90	25.4	17	70/80/85	12.1
BTCP0200060	CAT50-FA25.4	195	44.5	120	127.5	13.5	70	65	55	90	25.4	17	80/85/110	14.7

CPD Type

加長型橫向銑頭 Modular Angle Head-Longer

- The body is made of Ductile Cast Iron. High strength steel; stable machining.
- The AHC series is suitable for form and fast face milling.
- Can be automatic tool changed. Increases productivity.
 - 小型化設計、加長型下座，適用於深槽與深孔之內面加工。
 - 自動刀庫換刀加工，量化生產必備工具。

內孔偏差度	0.002 mm
材質	球狀石墨鑄鐵
轉速	最高 4000 RPM
扭力	最大 15Nm
齒輪比	1:1
適用主軸	BT, SK(ISO), CAT
標準配件	鉤形扳手、ER 扳手、 ER 螺帽
出力軸轉向	反轉

Run out	0.002 mm
Material	Ductile Cast Iron
R.P.M.	Max. 4000 RPM
Torque	Max. 15 Nm
Gear Ratio	1:1
Spindle Type	BT, SK(ISO), CAT
Standard Accessory	Hook Spanner, ER Wrench, ER Nut
Output Rotation	Reverse to Input Rotation

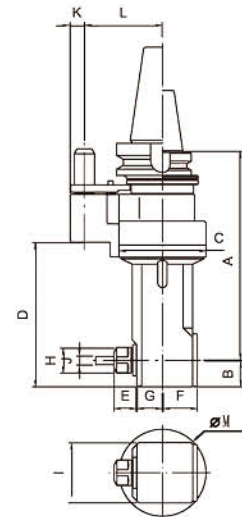

Code NO. 型號	TYPE 規格	A	B	C	D	E max	F	G	H	I	J	K	L	M	Unit/mm
															N.W.(KG)
BTCPD0400010	BT40-A1	227	29	95	156	38	38	28	34	66	1~13(ER20)	15.5	65/80/85	116	8.4
BTCPD0400020	BT50-A1	238	29	95	156	38	38	28	34	66	1~13(ER20)	15.5	80/85/110	116	11
BTCPD0400030	SK40-A1	227	29	95	156	38	38	28	34	66	1~13(ER20)	15.5	65/80/85	116	8.1
BTCPD0400040	SK50-A1	238	29	95	156	38	38	28	34	66	1~13(ER20)	15.5	80/85/110	116	10.8
BTCPD0400050	CAT40-A1	227	29	95	156	38	38	28	34	66	1~13(ER20)	15.5	65/80/85	116	8.1
BTCPD0400060	CAT50-A1	238	29	95	156	38	38	28	34	66	1~13(ER20)	15.5	80/85/110	116	10.8
BTCPD0400070	BT40-A3	227	29	95	156	47	38	28	42	66	2~16(ER25)	15.5	65/80/85	125	8.4
BTCPD0400080	BT50-A3	238	29	95	156	47	38	28	42	66	2~16(ER25)	15.5	80/85/110	125	11
BTCPD0400090	SK40-A3	227	29	95	156	47	38	28	42	66	2~16(ER25)	15.5	65/80/85	125	8.1
BTCPD0400100	SK50-A3	238	29	95	156	47	38	28	42	66	2~16(ER25)	15.5	80/85/110	125	10.8
BTCPD0400110	CAT40-A3	227	29	95	156	47	38	28	42	66	2~16(ER25)	15.5	65/80/85	125	8.1
BTCPD0400120	CAT50-A3	238	29	95	156	47	38	28	42	66	2~16(ER25)	15.5	80/85/110	125	10.8

* 此系列橫銑頭可選購延長器，以增加本體長度，詳細規格請見 P148。
* For longer length, Extension is available, whose specification is shown on P148.

CPD Type

小型橫向銑頭 Modular Angle Head-Compact

- Compact body design is the best tool for internal machining application.
- Can be automatic tool changed. Increases productivity.
 - 小型化外部設計，內面加工的最佳選擇。
 - 自動刀庫換刀加工，量化生產必備工具。

內孔偏擺度	0.002 mm
材質	球狀石墨鑄鐵
轉速	最高 4000 RPM
扭力	最大 15 Nm
齒輪比	1:1
適用主軸	BT, SK(ISO), CAT
標準配件	鉤形扳手、ER 扳手、ER 螺帽
出力軸轉向	反轉

Run out	0.002 mm
Material	Ductile Cast Iron
R.P.M.	Max. 4000 RPM
Torque	Max. 15 Nm
Gear Ratio	1:1
Spindle Type	BT, SK(ISO), CAT
Standard Accessory	Hook Spanner, ER Wrench, ER Nut
Output Rotation	Reverse to Input Rotation

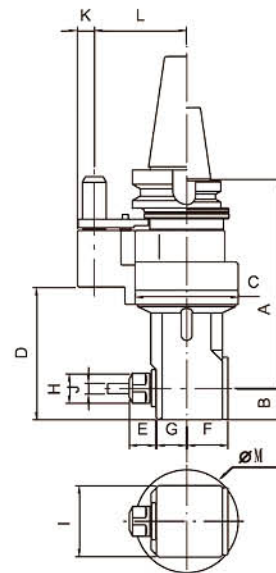

Code NO. 型號	TYPE 規格	A	B	C	D	E max	F	G	H	I	J	K	L	M	Unit/mm N.W.(KG)
BTCPD0500010	BT40-A2	192	29	95	122	38	38	28	34	66	1~13(ER20)	15.5	65/80/85	116	7.2
BTCPD0500020	BT50-A2	203	29	95	122	38	38	28	34	66	1~13(ER20)	15.5	80/85/110	116	10
BTCPD0500030	SK40-A2	192	29	95	122	38	38	28	34	66	1~13(ER20)	15.5	65/80/85	116	6.9
BTCPD0500040	SK50-A2	203	29	95	122	38	38	28	34	66	1~13(ER20)	15.5	80/85/110	116	9.8
BTCPD0500050	CAT40-A2	192	29	95	122	38	38	28	34	66	1~13(ER20)	15.5	65/80/85	116	6.9
BTCPD0500060	CAT50-A2	203	29	95	122	38	38	28	34	66	1~13(ER20)	15.5	80/85/110	116	9.8
BTCPD0500070	BT40-A4	192	29	95	122	47	38	28	42	66	2~16(ER25)	15.5	65/80/85	125	7.2
BTCPD0500080	BT50-A4	203	29	95	122	47	38	28	42	66	2~16(ER25)	15.5	80/85/110	125	10
BTCPD0500090	SK40-A4	192	29	95	122	47	38	28	42	66	2~16(ER25)	15.5	65/80/85	125	6.9
BTCPD0500100	SK50-A4	203	29	95	122	47	38	28	42	66	2~16(ER25)	15.5	80/85/110	125	9.8
BTCPD0500110	CAT40-A4	192	29	95	122	47	38	28	42	66	2~16(ER25)	15.5	65/80/85	125	6.9
BTCPD0500120	CAT50-A4	203	29	95	122	47	38	28	42	66	2~16(ER25)	15.5	80/85/110	125	9.8

* 此系列橫銑頭可選購延長器，以增加本體長度，詳細規格請見 p148。

*For longer length, Extension is available, whose specification is shown on p148.

CPD Type

45°橫向銑頭 Modular Angle Head-45°

- The 45 degree design ensures 45 degree drilling, milling and curved surface processing.
- Can be automatic tool changed . Increases productivity.
- 45° 設計，適用於 45° 鑽銑加工與曲面加工等。
- 自動刀庫換刀加工，量化生產必備工具。

內孔漏掃度	0.002 mm
材質	球狀石墨鑄鐵
轉速	最高 4000 RPM
扭力	最大 15Nm
齒輪比	1:1
適用主軸	BT, SK(ISO), CAT
標準配件	鉤形扳手、ER 扳手、 ER 螺帽
出力軸轉向	反轉

Run out	0.002 mm
Material	Ductile Cast Iron
R.P.M.	Max. 4000 RPM
Torque	Max. 15 Nm
Gear Ratio	1:1
Spindle Type	BT, SK(ISO), CAT
Standard Accessory	Hook Spanner, ER Wrench, ER Nut
Output Rotation	Reverse to Input Rotation

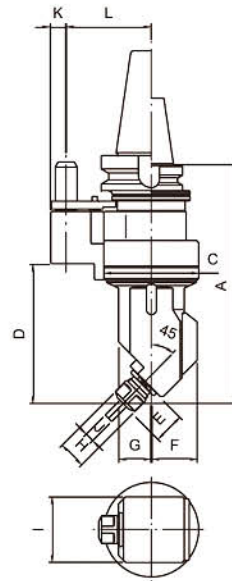

Code NO. 型號	TYPE 規格	A	C	D	E	F	G	H	I	J	K	L	Unit/mm
													N.W.(KG)
BTCPD0600010	BT40-B1	238	95	139	30	46	33	34	66	1~13(ER20)	15.5	65/85/80	7.4
BTCPD0600020	BT50-B1	249	95	139	30	46	33	34	66	1~13(ER20)	15.5	80/85/110	10.2
BTCPD0600030	SK40-B1	238	95	139	30	46	33	34	66	1~13(ER20)	15.5	65/85/80	7.1
BTCPD0600040	SK50-B1	249	95	139	30	46	33	34	66	1~13(ER20)	15.5	80/85/110	10
BTCPD0600050	CAT40-B1	238	95	139	30	46	33	34	66	1~13(ER20)	15.5	65/85/80	7.1
BTCPD0600060	CAT50-B1	249	95	139	30	46	33	34	66	1~13(ER20)	15.5	80/85/110	10

* 此系列橫銑頭可選購延長器，以增加本體長度，詳細規格請見 P148。
* For longer length, Extension is available, whose specification is shown on P148.

CPG Type

萬向銑頭 Universal Angle Head

- Cutting angle can be set from 0 to ± 90 degree for various applications.
- Compact design provides extra strength, oil-proof, dust-proof, and duration.
- Can be automatic tool changed. Increases productivity.
 - 0° ~ $\pm 90^\circ$ 加工角度多樣化，適用於各種加工應用。
 - 小型化設計、剛性高、防油、防塵佳、使用壽命長。
 - 自動刀庫換刀加工，量化生產必備工具。

內孔偏擺度	0.002 mm
材質	合金鋼 & 球狀石墨鑄鐵
轉速	最高 4000 RPM
扭力	最大 20 Nm
齒輪比	1:1
適用主軸	BT, SK(ISO), CAT
標準配件	開口扳手、ER 扳手、ER 螺帽
輸出軸轉向	反轉

Run out	0.002 mm
Material	Alloy Steel & Ductile Cast Iron
R.P.M.	Max. 4000 RPM
Torque	Max. 20 Nm
Gear Ratio	1:1
Spindle Type	BT, SK(ISO), CAT
Standard Accessory	Open End Wrench, ER Wrench, ER Nut
Output Rotation	Reverse to Input Rotation

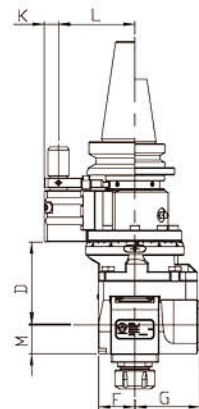
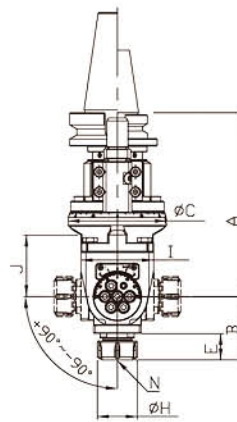

Unit/mm

Code NO. 型號	TYPE 規格	A	B max	C	D	E max	F	G	H	I	J	K	L	M	N	N.W.(KG)
BTCPD0700010	BT40-A1	184.5	89	103	87.6	32	38	70.7	42	76	64.5	17	65/80/85	29.5	2-16 (ER25)	9
BTCPD0700020	BT50-A1	195.5	89	103	87.6	32	38	70.7	42	76	64.5	17	80/85/110	29.5	2-16 (ER25)	11.5
BTCPD0700030	SK40-A1	184.5	89	103	87.6	32	38	70.7	42	76	64.5	17	65/80/85	29.5	2-16 (ER25)	9
BTCPD0700040	SK50-A1	195.5	89	103	87.6	32	38	70.7	42	76	64.5	17	80/85/110	29.5	2-16 (ER25)	11.5
BTCPD0700050	CAT40-A1	184.5	89	103	87.6	32	38	70.7	42	76	64.5	17	65/80/85	29.5	2-16 (ER25)	9
BTCPD0700060	CAT50-A1	195.5	89	103	87.6	32	38	70.7	42	76	64.5	17	80/85/110	29.5	2-20 (ER25)	11.5

CPK Type

鎖固式橫向銑頭 Heavy Duty Angle Head

- The output interface of BT40 ensures wide-range application with various BT40 tool holders.
- Mount directly on the machine spindle surface. Rugged body construction for heavy duty cutting.
- Interchangeable among same taper machines by changing the mounting plate.
- Hardened precision spiral bevel gears ensure stable performance with long service life.
- Cutting direction can be adjusted from 0 ~ 360 degree.
- BT40 刀具接合介面，提供各種 BT40 刀具之彈性應用，涵蓋大部分加工應用。
- 直接安裝於機台法蘭面。本體設計簡約，結構堅固。
- 藉由更換法蘭盤，可於相同錐度之各式機台上交替使用。
- 採用高硬度高精度螺旋傘齒輪，運轉穩定，壽命長。
- 可 360 度旋轉調整加工角度。

內孔漏掃度	0.002 mm
材質	球狀石墨鑄鐵
轉速	最高 4000 RPM
扭力	最大 100Nm
齒輪比	1:1
適用主軸	BT, SK(ISO), CAT
標準配件	開口扳手、L 型扳手
出力軸轉向	反轉

Run out	0.002 mm
Material	Ductile Cast Iron
R.P.M.	Max. 4000 RPM
Torque	Max. 100 Nm
Gear Ratio	1:1
Spindle Type	BT, SK(ISO), CAT
Standard Accessory	Open End Wrench, L Type Wrench
Output Rotation	Reverse to Input Rotation

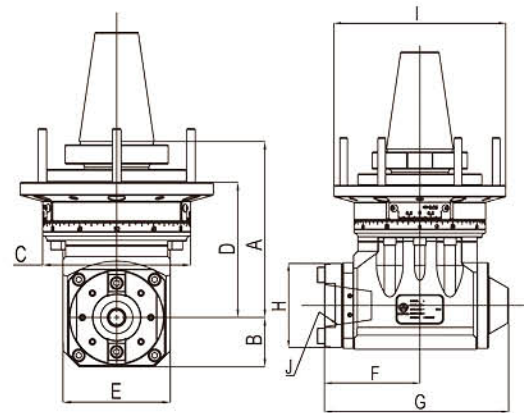

Code NO. 型號	TYPE 規格	A	B	C	D	E	F	G	H	I	J	N.W.(KG)
BTCPD0800010	BT40-A1G	164	46	138	126	100	100	193	88	180	BT40	17.3
BTCPD0800020	BT50-A1G	164	46	138	126	100	100	193	88	180	BT40	20
BTCPD0800030	SK40-A1G	164	46	138	126	100	100	193	88	180	BT40	17.3
BTCPD0800040	SK50-A1G	164	46	138	126	100	100	193	88	180	BT40	20
BTCPD0800050	CAT40-A1G	164	46	138	126	100	100	193	88	180	BT40	17.3
BTCPD0800060	CAT50-A1G	164	46	138	126	100	100	193	88	180	BT40	20

Unit/mm

CPK Type

鎖固式橫向銑頭 Heavy Duty Angle Head-Longer

- The output interface of BT40 ensures wide-range application with various BT40 tool holders.
- Mount directly on the machine spindle surface. Rugged body construction for heavy duty cutting.
- Interchangeable among same taper machines by changing the mounting plate.
- Hardened precision spiral bevel gears ensure stable performance with long service life.
- Cutting direction can be adjusted from 0 ~ 360 degree.
- 錐度 40 刀具接合介面，提供各種 BT40 刀具之彈性應用，涵蓋大部分加工應用。
- 直接安裝於機台法蘭面。本體設計簡約，結構堅固。
- 藉由更換法蘭盤，可於相同錐度之各式機台上交替使用。
- 採用高硬度高精密螺旋傘齒輪，運轉穩定，壽命長。
- 可 360 度旋轉調整加工角度。

內孔偏誤度	0.002 mm
材質	球狀石墨鑄鐵
轉速	最高 4000 RPM
扭力	最大 100 Nm
齒輪比	1:1
適用主軸	BT, SK(ISO), CAT
標準配件	開口扳手、L 型扳手
出力軸轉向	反轉

Run out	0.002 mm
Material	Ductile Cast Iron
R.P.M.	Max. 4000 RPM
Torque	Max. 100 Nm
Gear Ratio	1:1
Spindle Type	BT, SK(ISO), CAT
Standard Accessory	Open End Wrench, L Type Wrench
Output Rotation	Reverse to Input Rotation

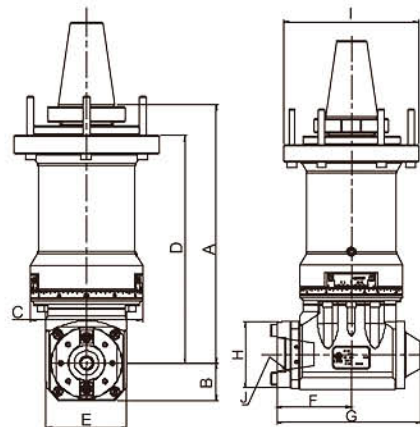

Code NO. 型號	TYPE 規格	A	B	C	D	E	F	G	H	I	J	Unit/mm	N.W.(KG)
BTCPK0900010	BT40-A2G	318	46	138	280	100	100	193	88	180	BT40		30.9
BTCPK0900020	BT50-A2G	318	46	138	280	100	100	193	88	180	BT40		33.6
BTCPK0900030	SK40-A2G	318	46	138	280	100	100	193	88	180	BT40		30.9
BTCPK0900040	SK50-A2G	318	46	138	280	100	100	193	88	180	BT40		33.6
BTCPK0900050	CAT40-A2G	318	46	138	280	100	100	193	88	180	BT40		30.9
BTCPK0900060	CAT50-A2G	318	46	138	280	100	100	193	88	180	BT40		33.6

CPK Type

抓刀式橫向銑頭 Multi - block Angle Head-BT

- The output interface of BT40 ensures wide- range application with various BT40 tool holder.
- Hardened precision spiral bevel gears ensure stable performance with long service life.
- Cutting direction can be adjusted from 0~360 degree.
- Multi-block support system improves working rigidity and stability.
- The automatic disengagement and engagement of Angle Head can be easily operated on the base of table and improve e ciency.
- Rugged Alloy Steel body construction with compact design.
- BT40 刀具接合介面，提供各種 BT40 刀具之彈性應用，涵蓋大部分加工應用。
- 採用高硬度高精密螺旋傘齒輪，運轉穩定，壽命長。
- 可 360 度旋轉調整加工角度。
- 多點支撐設計，可增加加工剛性及穩定性。
- 可於工作台上自動換刀，增加工作效率。
- 本體設計簡約，合金鋼本體結構堅固。

內孔偏滯度	0.002 mm
材質	合金鋼
轉速	最高 4000 RPM
扭力	最大 60 Nm
齒輪比	1:1
適用主軸	BT, SK(ISO), CAT
標準配件	開口扳手、L 型扳手
出力軸轉向	反轉

Run out	0.002 mm
Material	Alloy Steel
R.P.M.	Max. 4000 RPM
Torque	Max. 60 Nm
Gear Ratio	1:1
Spindle Type	BT, SK(ISO), CAT
Standard Accessory	Open End Wrench, L Type Wrench
Output Rotation	Reverse to Input Rotation

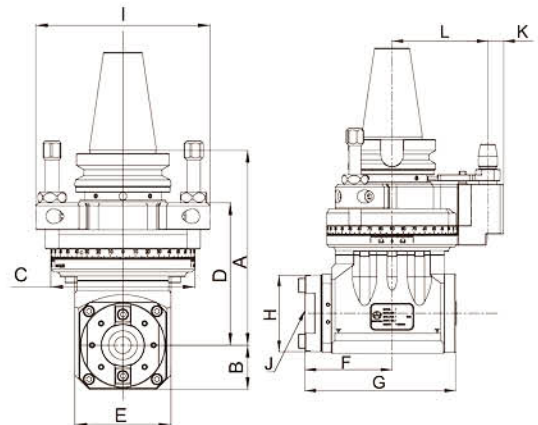

Code NO. 型號	TYPE 規格	A	B	C	D	E	F	G	H	I	J	K	L	N.W.(KG)
BTCPK0600010	BT50-B1	202.5	46	150	148	100	100	193	88	239	BT40	18	110	22.5
BTCPK0600020	SK50-B1	202.5	46	150	148	100	100	193	88	239	BT40	18	110	22.5
BTCPK0600030	CAT50-B1	202.5	46	150	148	100	100	193	88	239	BT40	18	110	22.5

Unit/mm

CPK Type

抓刀式橫向銑頭 Multi - block Angle Head-HSK

- The output interface of HSK63 ensures wide-range application with various HSK63 tool holders.
- Rugged Alloy Steel body construction with compact design.
- Hardened precision spiral bevel gears ensure stable performance with long service life.
- Cutting direction can be adjusted from 0 ~ 360 degree.
- Multi-block support system improves working rigidity and stability.
- The automatic disengagement and engagement of Angle Head can be easily operated on the base of table and improve efficiency.
- HSK63 刀具結合介面，提供各種 HSK63 刀具之彈性應用，涵蓋大部分加工應用。
- 本體設計簡約，合金鋼本體結構堅固。
- 採用高硬度高精度螺旋傘齒輪，運轉穩定，壽命長。
- 可 360 度旋轉調整加工角度。
- 多點支撐設計，可增加加工剛性及穩定性。
- 可於工作台上自動換刀，增加工作效率。

內孔偏誤度	0.002 mm
材質	合金鋼
轉速	最高 4000 RPM
扭力	最大 60 Nm
齒輪比	1:1
適用主軸	BT, SK(ISO), CAT
標準配件	開口扳手、L 型扳手
出力軸轉向	反轉

Run out	0.002 mm
Material	Alloy Steel
R.P.M.	Max. 4000 RPM
Torque	Max. 60 Nm
Gear Ratio	1:1
Spindle Type	BT, SK(ISO), CAT
Standard Accessory	Open End Wrench, L Type Wrench
Output Rotation	Reverse to Input Rotation

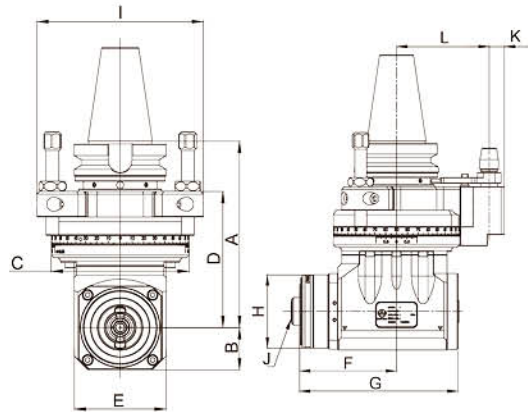

Code NO. 型號	TYPE 規格	A	B	C	D	E	F	G	H	I	J	K	L	Unit/mm
														NW.(KG)
BTCPK1000010	BT50-B2	202.5	46	150	148	100	115	208	87	239	HSK63	18	110	23.4
BTCPK1000020	SK50-B2	202.5	46	150	148	100	115	208	87	239	HSK63	18	110	23.4
BTCPK1000030	CAT50-B2	202.5	46	150	148	100	115	208	87	239	HSK63	18	110	23.4

CPK Type

抓刀式橫向銑頭(中心出水) Multi - block Angle Head-HSK (Int.)

- The output interface of HSK63 ensures wide-range application with various HSK63 tool holders.
- Hardened precision spiral bevel gears ensure stable performance with long service life.
 - Cutting direction can be adjusted from 0 ~ 360 degree.
 - Multi-block support system ensures working rigidity and stability.
 - The automatic disengagement and engagement of Angle Head can be easily operated on the base of table and improve efficiency.
 - Rugged Alloy Steel body construction with compact design.
 - HSK63 刀具結合介面，提供各種 HSK63 刀具之彈性應用，涵蓋大部分加工應用。
 - 本體設計簡約，合金鋼本體結構堅固。
 - 採用高硬度高精密螺旋傘齒輪，運轉穩定，壽命長。
 - 可 360 度旋轉調整加工角度。
 - 多點支撐設計，可增加加工剛性及穩定性。
 - 可於工作台上自動換刀，增加工作效率。

內孔偏溼度	0.002 mm
材質	合金鋼
轉速	最高 4000 RPM
扭力	最大 60 Nm
齒輪比	1:1
適用主軸	BT, SK(ISO), CAT
標準配件	開口扳手、L 型扳手
出力軸轉向	反轉
中心出水	30bar

Run out	0.002 mm
Material	Alloy Steel
R.P.M.	Max. 4000 RPM
Torque	Max. 60 Nm
Gear Ratio	1:1
Spindle Type	BT, SK(ISO), CAT
Standard Accessory	Open End Wrench, L Type Wrench
Output Rotation	Reverse to Input Rotation
Max. Coolant Bar	30bar

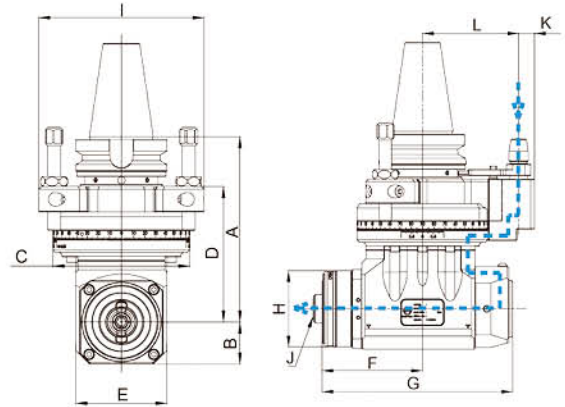

Code NO. 型號	TYPE 規格	A	B	C	D	E	F	G	H	I	J	K	L	N.W.(KG)
BTCPK1100010	BT50-B2-1	202.5	46	150	148	100	115	218	87	239	HSK63	18	110	23.4
BTCPK1100020	SK50-B2-1	202.5	46	150	148	100	115	218	87	239	HSK63	18	110	23.4
BTCPK1100030	CAT50-B2-1	202.5	46	150	148	100	115	218	87	239	HSK63	18	110	23.4

* Int : 中心出水 Internal Coolant

CPK Type

法蘭型自動換刀橫向銑頭(立車) Heavy Duty Angle Head (VTC)

- Can be applied on Vertical Turning Center, Plano Milling Machine and various machines with Adapter Plate.
- Built-in spindle positioning system. The exible design of connection part which is suitable for various magazines makes the ATC application possible.
- Can be connected to tooth-shaped Flange Disc or any shape of Machine Spindle surface to reach Max. rigidity.
- Hardened precision spiral bevel gears ensure stable performance with long service life.
- Cutting direction can be adjusted from 0~360 degree.
- 搭配轉接盤，可於立式車床、龍門銑床等各種不同機 台上使用。
- 主軸定位結構，可配合刀庫規格設計，自動換刀入刀 庫。
- 可與齒型連結盤或機台主軸端面形狀連結，達到最佳 化剛性。
- 採用高硬度高精度螺旋傘齒輪，運轉穩定，壽命長。
- 可 360 度旋轉調整加工角度。

內孔偏擺度	0.002 mm
材質	合金鋼
轉速	最高 4000 RPM
扭力	最大 60 Nm
齒輪比	1:1
適用主軸	BT, SK(ISO), CAT
標準配件	開口扳手、L 型扳手
出力軸轉向	反轉

Run out	0.002 mm
Material	Alloy Steel
R.P.M.	Max. 4000 RPM
Torque	Max. 60 Nm
Gear Ratio	1:1
Spindle Type	BT, SK(ISO), CAT
Standard Accessory	Open End Wrench, L Type Wrench
Output Rotation	Reverse to Input Rotation

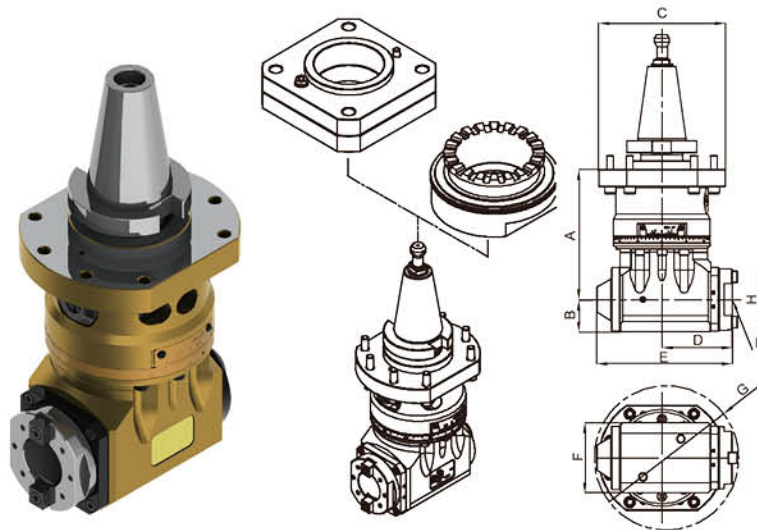

Code NO. 型號	TYPE 規格	A	B	C	D	E	F	G	H	I	N.W.(KG)
BTCPK1200010	BT50-C1	185	46	180	100	193	100	205	88	BT40	25.7
BTCPK1200020	SK50-C1	185	46	180	100	193	100	205	88	BT40	25.7
BTCPK1200030	CAT50-C1	185	46	180	100	193	100	205	88	BT40	25.7

Unit/mm

CPL Type

輕量化橫向銑頭 Light Angle Head

- Compact and lighter body design is suitable for drilling, milling, and tapping application.
- Can be automatic tool changed. Increases productivity.
- Enclosed Positioning Pin: Cutting Direction can be adjusted from 0~360 degrees.
 - It allows higher clamping torque and cutting direction could remain during the machining.
- 輕量化設計，適用於鑽銑加工及攻牙加工。
- 自動刀庫換刀加工，量化生產必備工具。
- 環抱型定位塊設計，可 360 度旋轉調整加工角度，並加強鎖固力道及加工角度精確性。

內孔漏掃度	0.002 mm
材質	合金鋼
轉速	最高 4000 RPM
扭力	最大 12 Nm
齒輪比	1:1
適用主軸	BT, SK(ISO), CAT
標準配件	開口扳手、L 型扳手、ER 螺帽
出力軸轉向	反轉

Run out	0.002 mm
Material	Alloy Steel
R.P.M.	Max. 4000 RPM
Torque	Max. 12 Nm
Gear Ratio	1:1
Spindle Type	BT, SK(ISO), CAT
Standard Accessory	Open End Wrench, L Type Wrench, ER Nut
Output Rotation	Reverse to Input Rotation

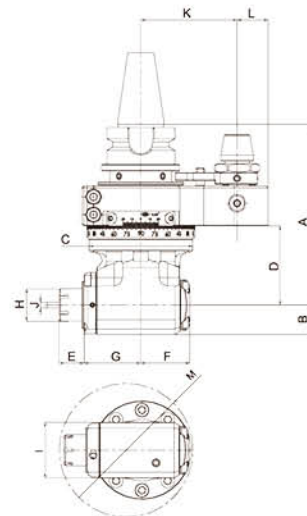

Code NO. 型號	TYPE 規格	Unit/mm													N.W.(KG)
		A	B	C	D	E	F	G	H	I	J	K	L	M	
BTCPL1300010	BT30-A1.55	122	20	70	53.5	17	33.1	38.3	22	39.5	1~10 (ER16)	55	21	95	3
BTCPL1300020	SK30-A1.55	122	20	70	53.5	17	33.1	38.3	22	39.5	1~10 (ER16)	55	21	95	3
BTCPL1300030	CAT30-A1.55	122	20	70	53.5	17	33.1	38.3	22	39.5	1~10 (ER16)	55	21	95	3
BTCPL1300040	BT30-A1.65	122	20	70	53.5	17	33.1	38.3	22	39.5	1~10 (ER16)	65	21	95	3
BTCPL1300050	BT40-A1.65	122	20	70	53.5	17	33.1	38.3	22	39.5	1~10 (ER16)	65	21	95	3.3
BTCPL1300060	SK30-A1.65	122	20	70	53.5	17	33.1	38.3	22	39.5	1~10 (ER16)	65	21	95	3
BTCPL1300070	SK40-A1.65	122	20	70	53.5	17	33.1	38.3	22	39.5	1~10 (ER16)	65	21	95	3.3
BTCPL1300080	CAT30-A1.65	122	20	70	53.5	17	33.1	38.3	22	39.5	1~10 (ER16)	65	21	95	3
BTCPL1300090	CAT40-A1.65	122	20	70	53.5	17	33.1	38.3	22	39.5	1~10 (ER16)	65	21	95	3.3

* 另有 6000 RPM 可供選擇

* Further option : 6000 RPM

CPL Type

90°橫向銑頭 90°Angle Head

- Compact and lighter body design is suitable for drilling, milling, and tapping application.
- Can be automatic tool changed. Increases productivity.
- Enclosed Positioning Pin: Cutting Direction can be adjusted from 0~360 degrees.
 - It allows higher clamping torque and cutting direction could remain during the machining.
- 輕量化設計，適用於鑽銑加工及攻牙加工。
- 自動刀庫換刀加工，量產生產必備工具。
- 環抱型定位塊設計，可 360 度旋轉調整加工角度，並加強鎖固力道及加工角度精確性。

內孔偏擺度	0.002 mm
材質	航太用鋁合金 / 球狀石墨鑄鐵 / 合金鋼
轉速	最高 6000 RPM
扭力	最大 30 Nm
齒輪比	1:1
適用主軸	BT, SK(ISO), CAT
標準配件	開口扳手、ER 扳手、ER 螺帽
出力軸轉向	反轉

Run out	0.002 mm
Material	Aerospace Alu. Alloy / Ductile Cast Iron / Alloy Steel
R.P.M.	Max. 6000 RPM
Torque	Max. 30 Nm
Gear Ratio	1:1
Spindle Type	BT, SK(ISO), CAT
Standard Accessory	Open End Wrench, L Type Wrench
Output Rotation	Reverse to Input Rotation

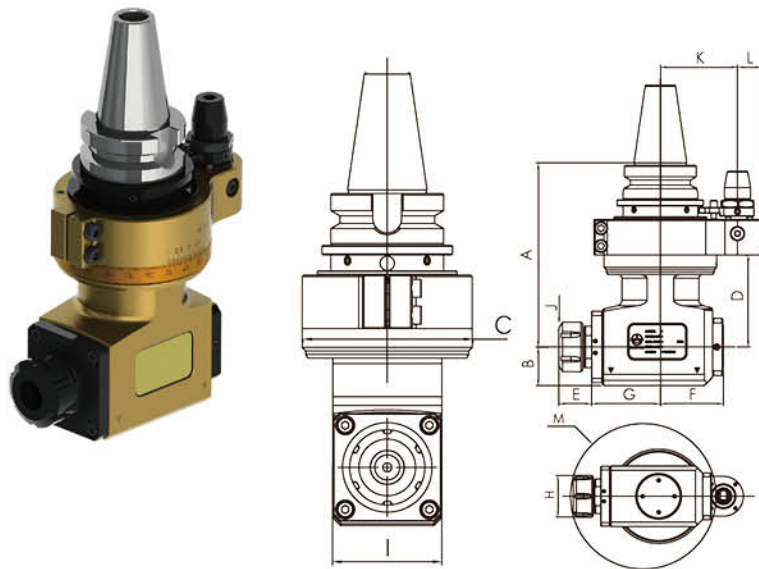

Code NO. 型號	TYPE 規格	A	B	C	D	E	F	G	H	I	J	K	L	M	N.W.(KG)
BTCPL1400010	BT40-A2.65	155	32.5	95	68.5	32	52.7	58	43	61	1~16 (ER25)	65	20	146	6.7
BTCPL1400020	SK40-A2.65	160.5	32.5	95	68.5	32	52.7	58	43	61	1~16 (ER25)	65	20	146	6.7
BTCPL1400030	CAT40-A2.65	160.5	32.5	95	68.5	32	52.7	58	43	61	1~16 (ER25)	65	20	146	6.7
BTCPL1400040	BT50-A2.80/110	162	32.5	95	68.5	32	52.7	58	43	61	1~16 (ER25)	80/110	20	146	9.1
BTCPL1400050	SK50-A2.80/110	162	32.5	95	68.5	32	52.7	58	43	61	1~16 (ER25)	80/110	20	146	9.1
BTCPL1400060	CAT50-A2.80/110	162	32.5	95	68.5	32	52.7	58	43	61	1~16 (ER25)	80/110	20	146	9.1
BTCPL1400070	BT40-A3.65	155	32.5	95	68.5	34	52.7	58	50	61	3~20 (ER32)	65	20	152	6.7
BTCPL1400080	SK40-A3.65	160.5	32.5	95	68.5	34	52.7	58	50	61	3~20 (ER32)	65	20	152	6.7
BTCPL1400090	CAT40-A3.65	160.5	32.5	95	68.5	34	52.7	58	50	61	3~20 (ER32)	65	20	152	6.7
BTCPL1400100	BT50-A3.80/110	162	32.5	95	68.5	34	52.7	58	50	61	3~20 (ER32)	80/110	20	152	9.1
BTCPL1400110	SK50-A3.80/110	162	32.5	95	68.5	34	52.7	58	50	61	3~20 (ER32)	80/110	20	152	9.1
BTCPL1400120	CAT50-A3.80/110	162	32.5	95	68.5	34	52.7	58	50	61	3~20 (ER32)	80/110	20	152	9.1

CPL Type

輕量化萬向銑頭 Light Angle Head-Universal

- Cutting angle can be set from 0° ~ ±120° for various applications.
- Compact design provides extra strength, oil-proof, dust-proof, and duration.
- Can be automatic tool changed. Increases productivity.
- Enclosed Positioning Pin: Cutting Direction can be adjusted from 0~360 degrees. It allows higher clamping torque and cutting direction could remain during the machining.
- 0° ~ ±120° 加工角度多樣化, 適用於各種加工應用。
- 小型化設計、剛性高、防油、防塵佳、使用壽命長。
- 自動刀庫換刀加工, 量化生產必備工具。
- 環抱型定位塊設計, 可 360 度旋轉調整加工角度, 並加強鎖固力道及加工角度精確性。

內孔漏掃度	0.002 mm
材質	合金鋼
轉速	最高 4000 RPM
扭力	最大 9 Nm
齒輪比	1:1
適用主軸	BT, SK(ISO), CAT
標準配件	開口扳手、ER 扳手、ER 螺帽
出力軸轉向	正轉

Run out	0.002 mm
Material	Alloy Steel
R.P.M.	Max. 4000 RPM
Torque	Max. 9 Nm
Gear Ratio	1:1
Spindle Type	BT, SK(ISO), CAT
Standard Accessory	Open End Wrench, ER Wrench, ER Nut
Output Rotation	Same as Input Rotation

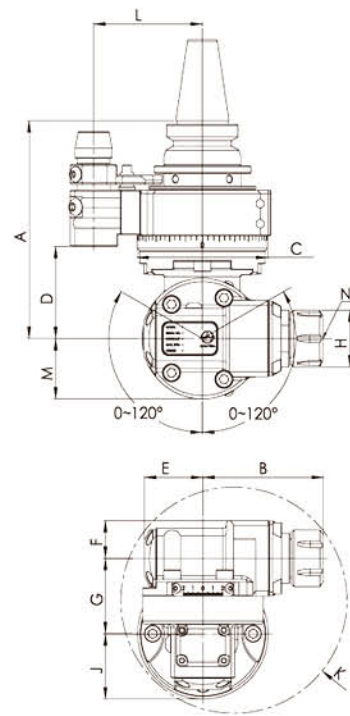

Code NO. 型號	TYPE 規格	A	B max	C	D	E	F	G	H	J	K	L	M	N	Unit/mm
															N.W.(KG)
BTCPL1500010	BT30-B1.55	130	72~79	73	61.5	34.5	22.5	45	36	36.5	140	55	36	1~13 (ER20)	4
BTCPL1500020	SK30-B1.55	130	72~79	73	61.5	34.5	22.5	45	36	36.5	140	55	36	1~13 (ER20)	4
BTCPL1500040	BT30-B1.65	130	72~79	73	61.5	34.5	22.5	45	36	36.5	140	65	36	1~13 (ER20)	4
BTCPL1500050	BT40-B1.65	130	72~79	73	61.5	34.5	22.5	45	36	36.5	140	65	36	1~13 (ER20)	4.5
BTCPL1500060	SK30-B1.65	130	72~79	73	61.5	34.5	22.5	45	36	36.5	140	65	36	1~13 (ER20)	4
BTCPL1500070	SK40-B1.65	130	72~79	73	61.5	34.5	22.5	45	36	36.5	140	65	36	1~13 (ER20)	4.5
BTCPL1500090	CAT40-B1.65	130	72~79	73	61.5	34.5	22.5	45	36	36.5	140	65	36	1~13 (ER20)	4.5

CPL Type

細長型橫向銑頭 Modular Angle Head-Ultra Slim

- Compact and longer body design is suitable for machining the deep-hole and deep-slot.
- Can be automatic tool changed. Increases productivity.
- Cutting Direction can be adjusted from 0~360 degrees.
 - 小型化設計、加長型下座，適用於深槽與深孔之內面加工。
 - 自動刀庫換刀加工，量化生產必備工具。
 - 可 360 度旋轉調整加工角度。

材質	合金鋼
轉速	最高 4000 RPM
扭力	C1: 最大 6 Nm D1: 最大 12 Nm
鑽孔	最大 6 mm
攻牙	C1: 最大 M4 D1: 最大 M6
齒輪比	1:1
適用主軸	BT, SK(ISO), CAT
標準配件	T 型扳手

Material	Alloy Steel
R.P.M.	Max. 4000 RPM
Torque	C1: Max. 6 Nm D1: Max. 12 Nm
Drilling	Max. 6 mm
Tapping	C1: Max. M4 D1: Max. M6
Gear Ratio	1:1
Spindle Type	BT, SK(ISO), CAT
Standard Accessory	Open End Wrench, ER Wrench, ER Nut

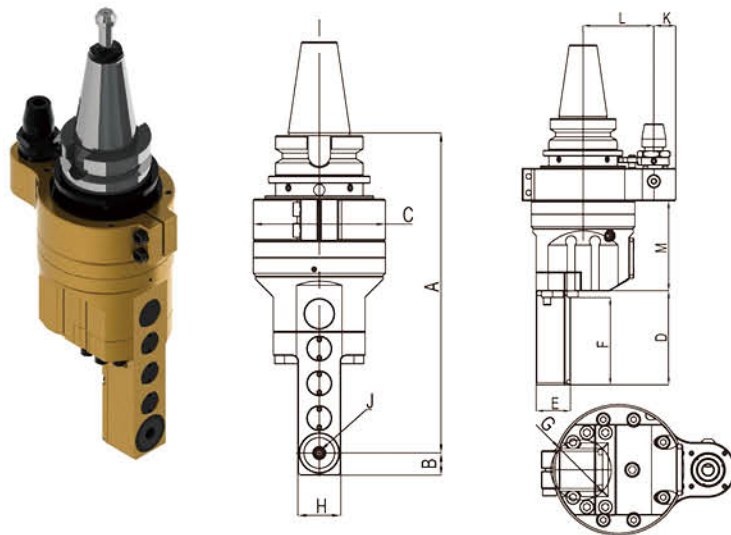

Code NO. 型號	TYPE 規格	A	B	C	D	E	F	G	H	J	K	L	M	Unit/mm NLW(KG)
BTCPL1700010	BT40-C4.65	230	16	95	86	31.5	80	44	31	2~6 (ADC6)	20	65	82.5	6.6
BTCPL1700020	BT50-C4.80	237	16	95	86	31.5	80	44	31	2~6 (ADC6)	20	80	82.5	9
BTCPL1700030	BT50-C4.110	237	16	95	86	31.5	80	44	31	2~6 (ADC6)	20	110	82.5	9
BTCPL1700040	SK40-C4.65	230	16	95	86	31.5	80	44	31	2~6 (ADC6)	20	65	82.5	6.6
BTCPL1700050	SK50-C4.80	237	16	95	86	31.5	80	44	31	2~6 (ADC6)	20	80	82.5	9
BTCPL1700060	SK50-C4.110	237	16	95	86	31.5	80	44	31	2~6 (ADC6)	20	110	82.5	9
BTCPL1700070	CAT40-C4.65	230	16	95	86	31.5	80	44	31	2~6 (ADC6)	20	65	82.5	6.6
BTCPL1700080	CAT50-C4.80	237	16	95	86	31.5	80	44	31	2~6 (ADC6)	20	80	82.5	9
BTCPL1700090	CAT50-C4.110	237	16	95	86	31.5	80	44	31	2~6 (ADC6)	20	110	82.5	9

* 此橫銑頭須採用我司特製 ADC 筒夾
* This Angle Head requires the adoption of special ADC collet.

CPM Type

鋁合金橫向銑頭 Aluminum Angle Head

- 6000 rpm high speed processing. Increases machining efficiency.
- Compact and lighter body design is suitable for machines with light-load magazine and high speed ATC system.
- Can be automatic tool changed. Increases productivity.
- Cutting Direction can be adjusted from 0~360 degrees.
- 6000 PRM 高轉速加工，提高加工效率。
- 輕量化設計，適用於輕型及高速自動換刀之機台。
- 自動刀庫換刀加工，量化生產必備工具。
- 可 360° 旋轉調整加工角度。

內孔漏掃度	0.002 mm
材質	航太用鋁合金
轉速	最高 6000 RPM
扭力	最大 15 Nm
齒輪比	1:1
適用主軸	BT, SK(ISO), CAT
標準配件	開口扳手、ER 扳手、ER 螺帽
出力軸轉向	反轉

Run out	0.002 mm
Material	Aerospace Aluminum Alloy
R.P.M.	Max. 6000 RPM
Torque	Max. 15 Nm
Gear Ratio	1:1
Spindle Type	BT, SK(ISO), CAT
Standard Accessory	Open End Wrench, ER Wrench, ER Nut
Output Rotation	Reverse to Input Rotation

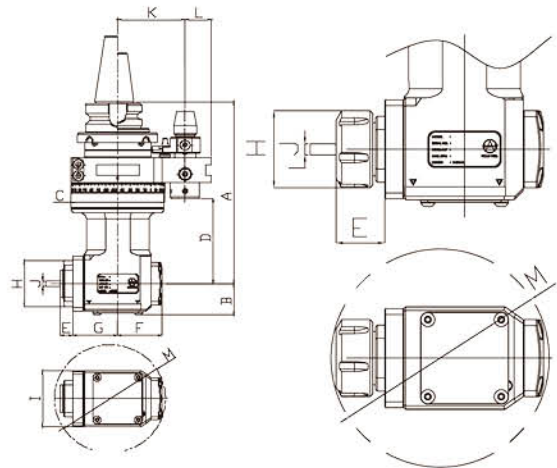

Code NO. 型號	TYPE 規格	Unit/mm													N.W.(KG)
		A	B	C	D	E	F	G	H	I	J	K	L	M	
BTCPM1900010	BT30-A04.180G	180	31.2	90	84.5	26.5	43	43.5	42	60	1~16 (ER25)	65	25	120	4.5
BTCPM1900020	BT40-A04.180G	180	31.2	90	84.5	26.5	43	43.5	42	60	1~16 (ER25)	65	25	120	5
BTCPM1900030	SK30-A04.180G	180	31.2	90	84.5	26.5	43	43.5	42	60	1~16 (ER25)	65	25	120	4.5
BTCPM1900040	SK40-A04.180G	180	31.2	90	84.5	26.5	43	43.5	42	60	1~16 (ER25)	65	25	120	5
BTCPM1900060	CAT40-A04.180G	180	31.2	90	84.5	26.5	43	43.5	42	60	1~16 (ER25)	65	25	120	5
BTCPM1900070	BT30-A10.180G	180	31.2	90	84.5	12	43	43.5	45	60	1~13 (ER20 I.N)	65	25	105	4.5
BTCPM1900080	BT40-A10.180G	180	31.2	90	84.5	12	43	43.5	45	60	1~13 (ER20 I.N)	65	25	105	5
BTCPM1900090	SK30-A10.180G	180	31.2	90	84.5	12	43	43.5	45	60	1~13 (ER20 I.N)	65	25	105	4.5
BTCPM1900100	SK40-A10.180G	180	31.2	90	84.5	12	43	43.5	45	60	1~13 (ER20 I.N)	65	25	105	5
BTCPM1900120	CAT40-A10.180G	180	31.2	90	84.5	12	43	43.5	45	60	1~13 (ER20 I.N)	65	25	105	5

* I.N.: 內牙 Internal Nut

CPM Type

鋁合金橫向銑頭(中心出水) Aluminum Angle Head (Int.)

- 6000 rpm high speed processing. Increases machining efficiency.
- Compact and lighter body design is suitable for machines with light-load magazine and high speed ATC system.
 - Can be automatic tool changed. Increases productivity.
 - Cutting Direction can be adjusted from 0~360 degrees.
- 6000 PRM 高轉速加工，提高加工效率。
- 輕量化設計，適用於輕型及高速自動換刀之機台。
- 自動刀庫換刀加工，量產生產必備工具。
- 可 360° 旋轉調整加工角度。

內孔偏誤度	0.002 mm
材質	航太用鋁合金
轉速	最高 6000 RPM
扭力	最大 15 Nm
齒輪比	1:1
通用主軸	BT, SK(ISO), CAT
標準配件	開口扳手、ER 扳手、ER 螺帽
出力軸轉向	反轉
中心出水	30bar

Run out	0.002 mm
Material	Aerospace Aluminum Alloy
R.P.M.	Max. 6000 RPM
Torque	Max. 15 Nm
Gear Ratio	1:1
Spindle Type	BT, SK(ISO), CAT
Standard Accessory	Open End Wrench, ER Wrench, ER Nut
Output Rotation	Reverse to Input Rotation
Max. Coolant Bar	30bar

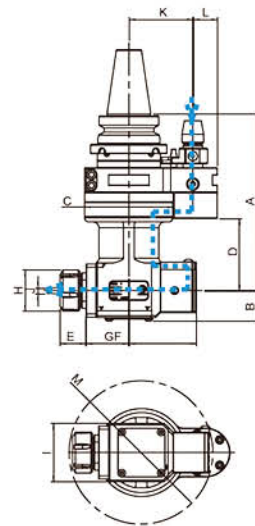

Code NO. 型號	TYPE 規格	A	B	C	D	E	F	G	H	I	J	K	L	M	NW (KG)
BTCPM2000010	BT30-A04.180G-1	180	31.2	90	84.5	26.5	68.7	43.5	42	60	1~16 (ER25)	65	25	120	5.3
BTCPM2000020	BT40-A04.180G-1	180	31.2	90	84.5	26.5	68.7	43.5	42	60	1~16 (ER25)	65	25	120	5.8
BTCPM2000030	SK30-A04.180G-1	180	31.2	90	84.5	26.5	68.7	43.5	42	60	1~16 (ER25)	65	25	120	5.3
BTCPM2000040	SK40-A04.180G-1	180	31.2	90	84.5	26.5	68.7	43.5	42	60	1~16 (ER25)	65	25	120	5.8
BTCPM2000060	CAT40-A04.180G-1	180	31.2	90	84.5	26.5	68.7	43.5	42	60	1~16 (ER25)	65	25	120	5.8

* Int. : 中心出水 Internal Coolant

CPM Type

鋁合金後縮橫向銑頭 Aluminum Offset Angle Head

- The output interface of BT40 ensures wide-range application with various BT40 Tool Holder.
- O set design ensures compact body and largely eliminates interference.
- O set design eliminates the protrusion of tools and enhances working rigidity.
- Special tool-locking design ensures easier tool engagement and release.
- Can be automatic tool changed. Increases productivity.
- Cutting Direction can be adjusted from 0~360 degrees.
- BT 40 刀具接合介面，提供各種 BT40 刀具之彈性應用，涵蓋大部分加工應用。
- 採用後縮設計，減少本體長度，降低工件干涉。
- 刀具加工支點靠近橫銑頭中心增加加工剛性。
- 拆刀、鎖刀扳手設計，方便拆鎖刀時固定橫向軸與施力。
- 自動刀庫換刀加工，量化生產必備工具。
- 可 360 度旋轉調整加工角度。

內孔偏溼度	0.002 mm
材質	航太用鋁合金 / 合金鋼
轉速	最高 4000 RPM
扭力	最大 50 Nm
齒輪比	1:1
適用主軸	BT, SK(ISO), CAT
標準配件	鎖刀板、L 型扳手
出力軸轉向	正轉

Run out	0.002 mm
Material	Aerospace Aluminum Alloy/ Alloy Steel
R.P.M.	Max. 4000 RPM
Torque	Max. 50 Nm
Gear Ratio	1:1
Spindle Type	BT, SK(ISO), CAT
Standard Accessory	Tool-Locking Plate, L type Wrench
Output Rotation	Same as Input Rotation

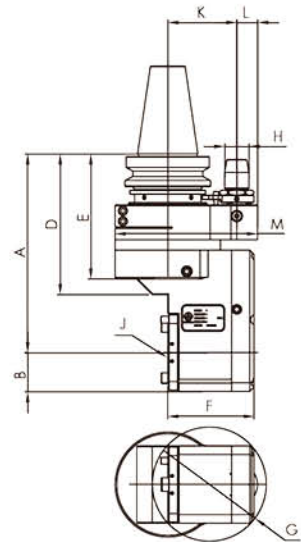
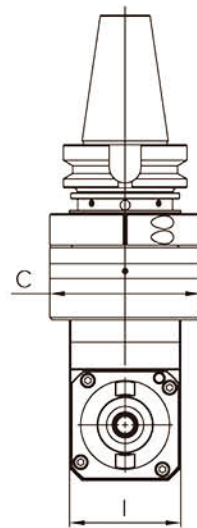

Code NO. 型號	TYPE 規格	A	B	C	D	E	F	G	H	I	J	K	L	M	N.W.(KG)
BTCPM2100010	BT50-D42.230	230	45	122	163	145	100	132	28	90	BT40	80/85/110	24	165	14.8
BTCPM2100020	SK50-D42.230	230	45	122	163	145	100	132	28	90	BT40	80/85/110	24	165	14.8
BTCPM2100030	CAT50-D42.230	230	45	122	163	145	100	132	28	90	BT40	80/85/110	24	165	14.8

選購配件 Optional Accessory

定位塊 Setting Block / Stopper

- Standard - Taper 40
- Code No. - BTCPT4220010
- Type - Taper40 ICP-00288

- 標準錐度 - 40

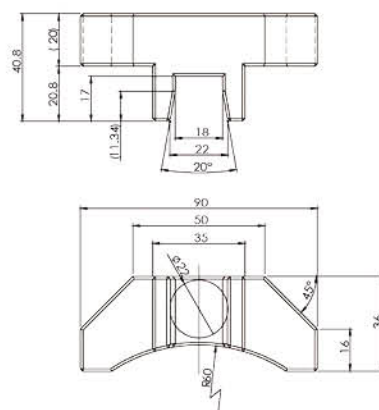

- Standard - Taper 50
- Code No. - BTCPT5220010
- Type - Taper50 ICP-00289

- 標準錐度 - 50

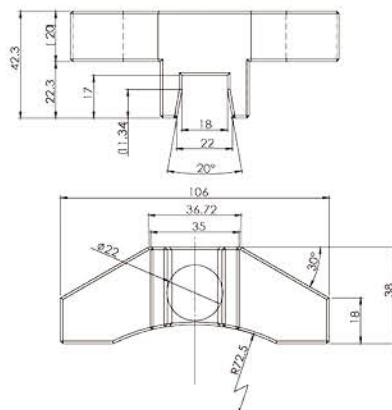

客製化定位塊 Customized Setting Block / Stopper

- Code No. - BTCPT5230010
- Type - BT-1



* 圖面僅供參考。實際的定位塊規格視客戶機台主軸尺寸不同而定。
 * For reference only. The real specification would vary from different machine spindle dimensions.

選購配件 Optional Accessory

客製法蘭盤 Customized Flange

- CPK-A1 Series Only
- Code No. - BTCPK08P0010
- Type - BT-2

· CPK-A1 專用



延長器 Extension

- CPD Series Only

· CPD 系列專用

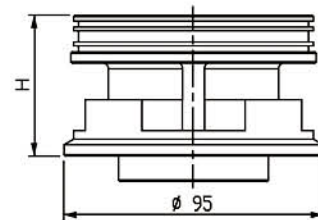

Unit/mm

Code NO. 型號	TYPE 規格	H
BTCPDE1P0010	E1	50
BTCPDE1P0020	E2	100

筒夾 Collet

- CPK-A1 Series Only
- Code No. - BTCPLADP0010
- Type - BT-2

· CPK-A1 專用

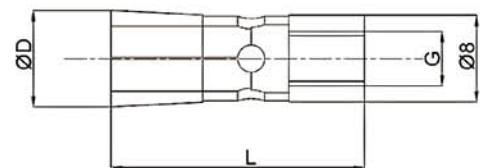

Unit/mm

Code NO. 型號	TYPE 規格	Metric Size	D	L	G	N.W.(KG)
BTCPPLADP0010	ADC6	2/3/4/5/6	8.9	23.5	M5*P0.8	0.005