

Zero Point 零點定位器 Clamping System

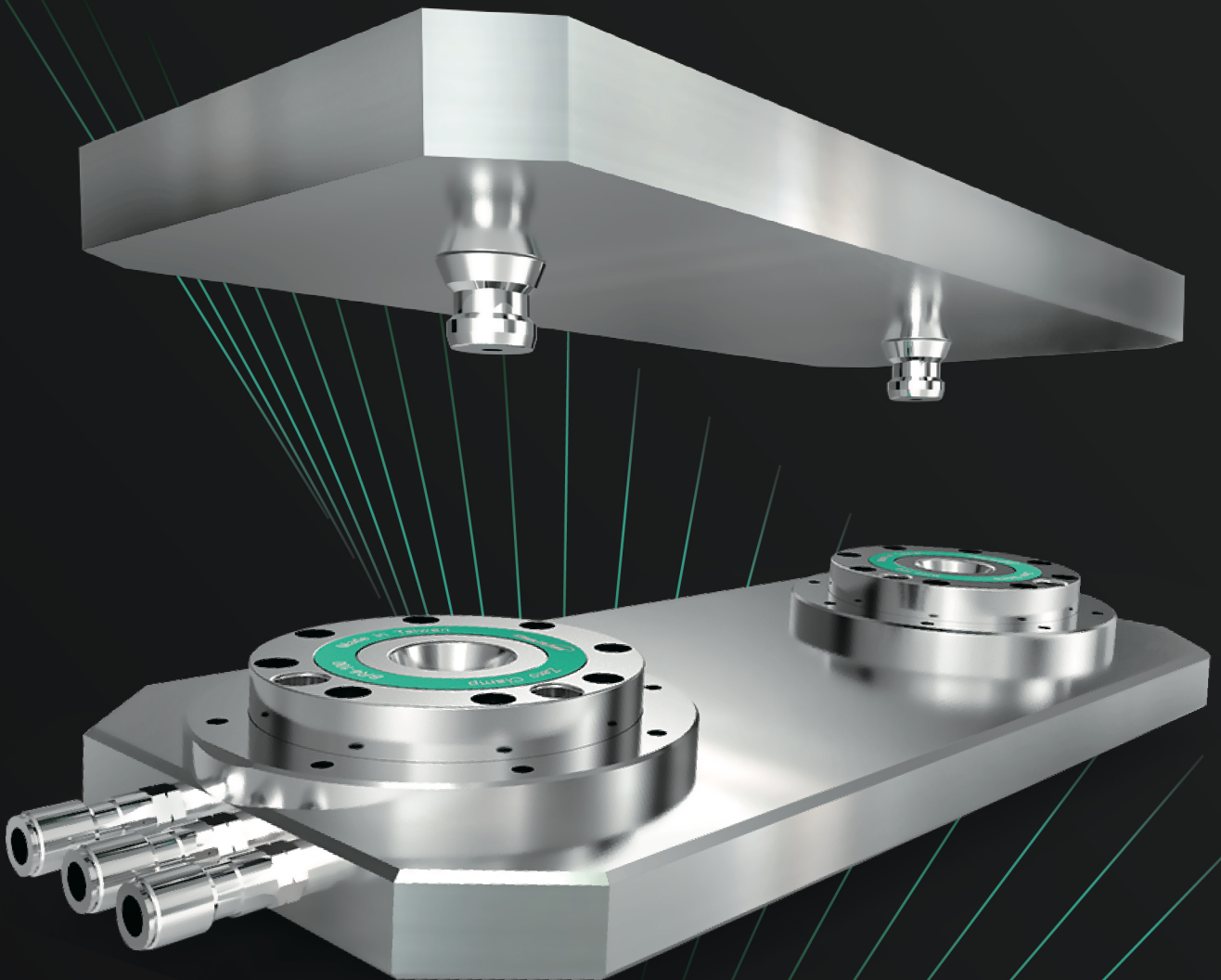

Introduction

介紹

CHUMPOWER Zero Point Clamping System can quickly change the clamp, effectively shorten the replacement time of production line, and greatly improve the production efficiency.

Its main part is made of stainless steel, the repeat positioning accuracy reach to 0.005mm; Also, the central hole with cleaning function can eliminates iron filings and impurities. It only needs 6kg / cm² air supply pressure to start the Zero Point Clamping System, could reduce the production costs easily.

銓寶零點定位器可快速更換夾治具，有效縮短更換產線時間，大幅提升生產效率。

主體零件由不銹鋼製成，重複定位精度達0.005mm；具有中心孔吹氣功能排除鐵屑及雜質，使加工工件更加完美，並且只需6kg/cm²供氣壓力即可啟動零定位點夾持，輕鬆降低生產成本。

Installation

安裝

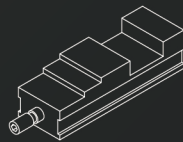

MC Mechanical Power Vise
機械虎鉗

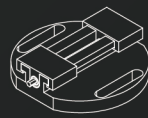

Self Centring Vise
同動求心虎鉗
(Screw lock - 螺絲鎖固)

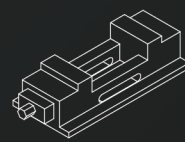

Self Centring Vise
同動求心虎鉗
(Platen lock - 壓板鎖固)

Optional 選項



One Fixture 單穴子板



Two Pallet 兩穴子板

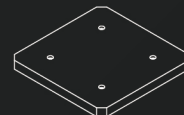

Four Pallet 四穴子板

Machine Table
工具機床台

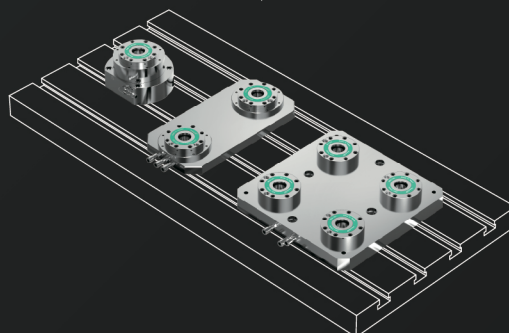

Application

產品適用

CNC Milling Machine

CNC銑床工具機

Traditional Milling Machine/
Special Purpose Machine

傳統銑床/
專用加工機

Other Type of Machine
(Welding 、 EDM 、 Wire Cutting)

特殊加工機
(焊接、放電、線割)

Efficiency

生產效率

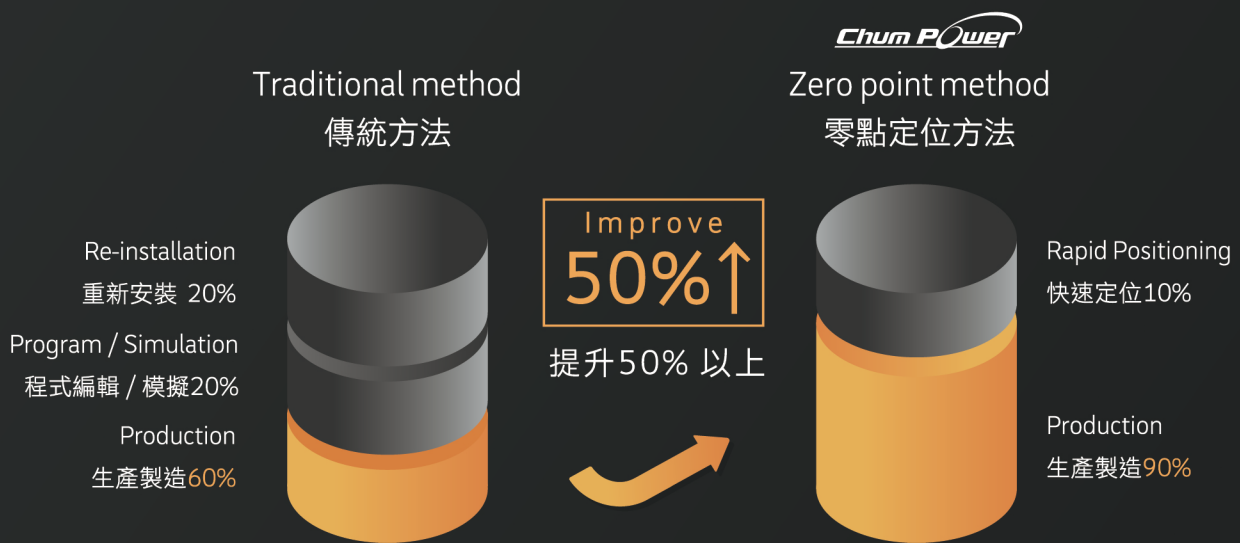

Depend on processing conditions 依照加工條件不同而有所變更

Ø65 1-way Clamping Bracket

直徑 65 單主體組

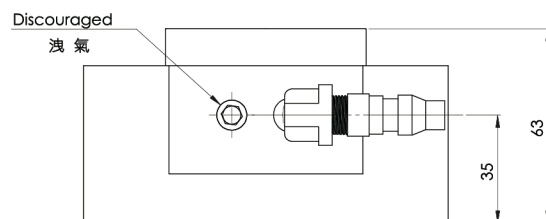
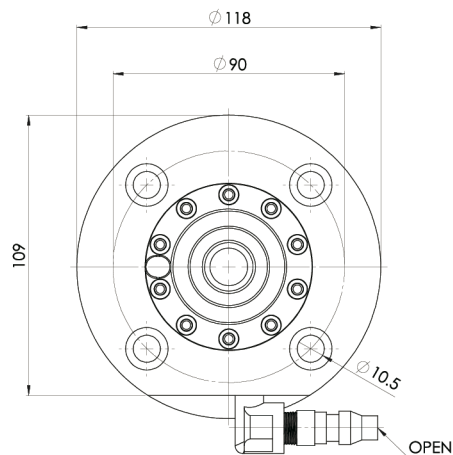

Specification 規格			
Item No. 產品編號	Size 產品大小	Kg 重量	Material 材質
BR4A206500001A	Ø65 型	1.65kg	Body 主體 -Stainless 不鏽鋼

Ø100/Ø130 1-way Clamping Bracket

直徑 100/130 單主體組

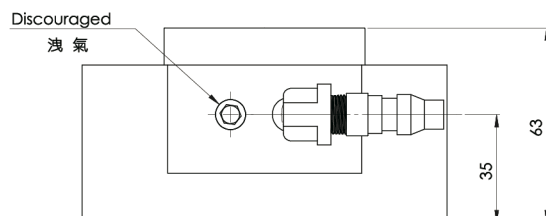
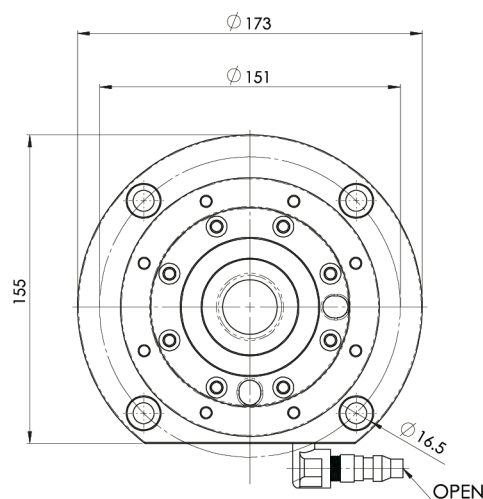
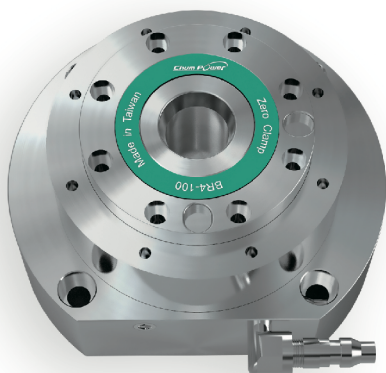

Specification 規格			
Item No. 產品編號	Size 產品大小	Kg 重量	Material 材質
BR4A210000001A	Ø100 型	5.5	Body 主體 -Stainless 不鏽鋼
BR4A213000001A	Ø130 型	6.1	

Ø65/Ø100/Ø130 2-way Clamping Bracket

直徑 65/100/130 雙主體組

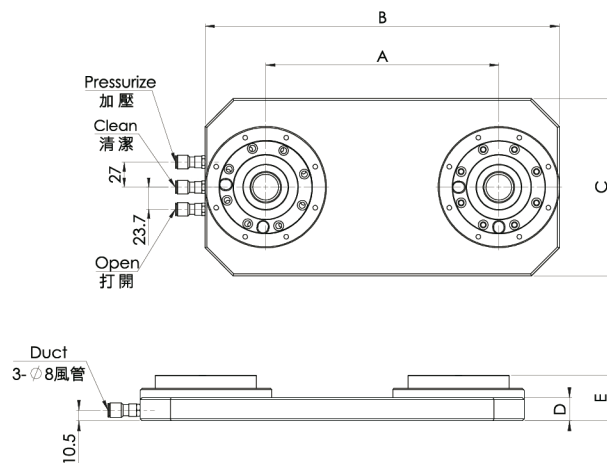

Specification 規格								
Item No. 產品編號	Size 產品大小	A(mm) 間距	B(mm) 全長	C(mm) 全長	D(mm) 板高	E(mm) 全高	Kg 重量	Material 材質
BR4B306500001A	Ø65 型	100	205	85	30	39	3.9	Body 主體 -Stainless 不鏽鋼
BR4B310000001A	Ø100 型	200	338	190	23	45	14	
BR4B313000001A	Ø130 型	200	338	190	23	45	15.2	

Ø65/Ø100/Ø130 4-way Clamping Bracket

直徑 65/100/130 四主體組

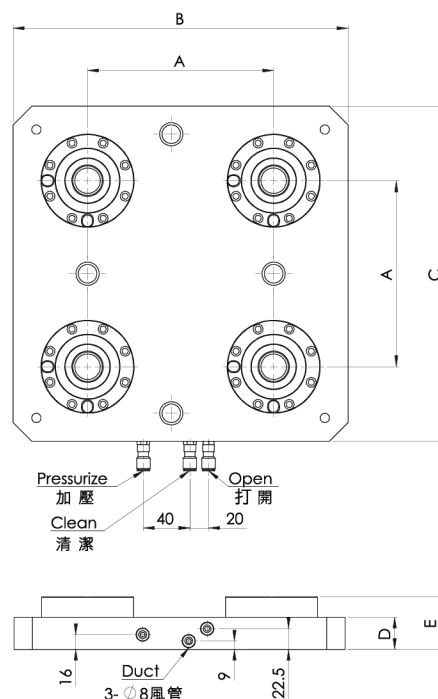
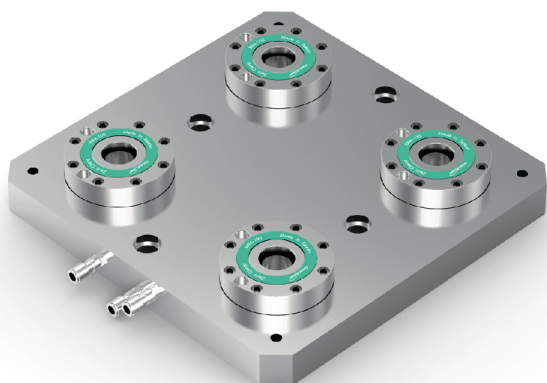

Specification 規格								
Item No. 產品編號	Size 產品大小	A(mm) 間距	B(mm) 全長	C(mm) 全長	D(mm) 板高	E(mm) 全高	Kg 重量	Material 材質
BR4D310000001A	Ø130 型	200	360	360	35	57	39.4kg	Body 主體 -Stainless 不鏽鋼



Integrity to build reputation

Quality to determine future

Innovation to accomplish dream

Service to customer satisfaction

 **PayPal** below USD 2,000

CHUMPOWER MACHINERY CORPORATION

No.688-1, Sec. 3, Zhongshan Rd., Wuri Dist, Taichung City 414, Taiwan 414 台中市烏日區中山路三段 688-1 號
TEL 886-4-2338-8289 FAX 886-4-2335-5626 Email dali@chumpower.com

