

CNC REVOLVING CENTER SERIES

迴轉頂針系列



CNC HEAVY DUTY 'R'

重型R系列

APPLICATION

- CNC Heavy Duty - R Model is suitable for high speed and high load applications on CNC Turning Machine.
- This design is most popular and fastest selling design.
- The quality and performance is comparable to the best European makes of Germany and Italy.

DESIGN FEATURES

- It is a triple bearing design with High Precision bearings used of European & Japanese make.
- The bearings are lubricated for life with Kluber Germany make ISO Flex NBU 15 Grease.
- Body material: 20MnCr5 (Equivalent to SAE 8620) case hardened to 55-58 HRC.
- Point Material: Bearing steel EN-31(Equivalent to SAE 52100) hardened to 60HRC.
- Good Quality Dual Lip Seal System prevents entry of dust & coolant into the bearing assembly.
- Runout less than 0.005 mm. (0.010mm for MT-6)
- POINT STYLE (NOSE STYLE) 60 Degrees

應用

- 重型 R 系列適用於 CNC 車床上的高速強力切削
- 此設計是銷售最好且最受歡迎的產品
- 品質和性能可與歐洲德國及義大利的最佳品牌相媲美

特性

- 採用歐洲和日本製造的高精度三軸承設計
- 軸承的潤滑油採德國克魯勃 (Kluber Germany) 生產的 ISO Flex NBU 15
- 本體材質：20MnCr5（相當於 SAE 8620），硬度 55-58 HRC
- 尖端材質：軸承鋼 EN-31（相當於 SAE 52100），硬度 60HRC
- 雙層密封系統可防止灰塵和冷卻劑進入軸承組件
- 精度小於 0.005 mm (MT-6 為 0.010mm)
- 尖端類型為 60 度



HDR-01 (STUB POINT) 重型R系列

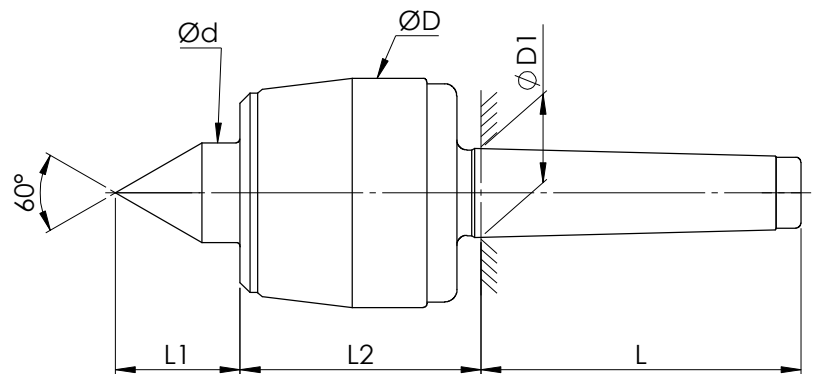

Code No. 型號	Type 規格	Shank Taper 刀柄 ØD1 mm	Ød mm	ØD mm	L1 mm	L2 mm	L mm	Max. Job Wt. Kg 加工件重量	Conc. Error mm 精度	Max. RPM 迴轉速
BTSMC110010A	HDR-01-2A	MT2 (17.78)	20	46	25.0	48.5	64.0	200	0.005	7000
BTSMC110011A	HDR-01-3A	MT3 (23.825)	28	62	34.0	62.5	81.0	500	0.005	5000
BTSMC110012A	HDR-01-4A	MT4 (31.267)	32	68	41.0	65.0	102.0	800	0.005	3800
BTSMC110013A	HDR-01-5A	MT5 (44.399)	38	87	51.0	80.0	129.5	2000	0.005	3000
BTSMC110014A	HDR-01-6A	MT6 (63.348)	55	112	63.0	106.0	182	3500	0.010	2600

HDR-02 (EXTENDED POINT) 重型R系列

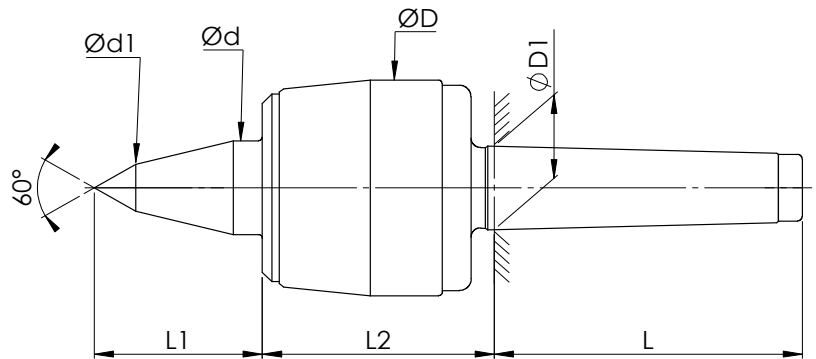

Code No. 型號	Type 規格	Shank Taper 刀柄 ØD1 mm	Ød1 mm	Ød mm	ØD mm	L1 mm	L2 mm	L mm	Max. Job Wt. Kg 加工工件重量	Conc. Error mm 精度	Max. RPM 迴轉速
BTSMC110020A	HDR-02-2A	MT2(17.78)	10	20	46	35.0	48.5	64.0	140	0.005	7000
BTSMC110021A	HDR-02-3A	MT3(23.825)	12	28	62	51.0	62.5	81.0	400	0.005	5000
BTSMC110022A	HDR-02-4A	MT4(31.267)	14	32	68	54.5	65.0	102.5	500	0.005	3800
BTSMC110023A	HDR-02-5A	MT5(44.399)	16	38	87	65.0	80.5	129.5	1200	0.005	3000
BTSMC110024A	HDR-02-6A	MT6(63.348)	18	55	112	95.0	106.0	182.0	2500	0.010	2600

HRD-03 (PROFILED POINT) 重型R系列

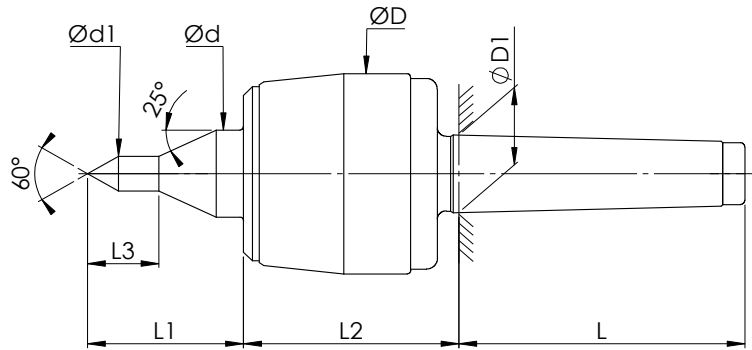

Code No. 型號	Type 規格	Shank Taper 刀柄 ØD1 mm	Ød mm	ØD mm	L1 mm	L2 mm	L3 mm	L mm	Max. Job Wt. Kg 加工件重量	Conc. Error mm 精度	Max. RPM 迴轉速
BTSMC110030A	HDR-03-2A	MT2(17.78)	8	20	46	48.5	16	64.0	100	0.005	7000
BTSMC110031A	HDR-03-3A	MT3(23.825)	10	28	62	62.5	20	81.0	150	0.005	5000
BTSMC110032A	HDR-03-4A	MT4(31.267)	12	32	68	65.0	26	102.5	180	0.005	3800
BTSMC110033A	HDR-03-5A	MT5(44.399)	14	38	87	80.5	30	129.5	280	0.005	3000

CNC MEDIUM DUTY SLIMLINE

中型細長系列

APPLICATION

- CNC Medium Duty with Slimline Model is suitable for very high rpm requirement in excess of what the CNC Heavy Duty R Model is suitable for.
- Suitable only for medium duty applications for very small & medium size work pieces.
- Suitable for work pieces with high L/D (length to diameter) ratio due to roller bearing assembly.

DESIGN FEATURES

- It is a triple bearing design with High Precision bearings used of European & Japanese make.
- The bearings are lubricated for life with Kluber Germany make ISO Flex NBU 15 Grease.
- Body material: 20MnCr5 (Equivalent to SAE 8620) case hardened to 55-58 HRC.
- Point Material: Bearing steel EN-31 (Equivalent to SAE 52100) hardened to 60HRC.
- Good Quality Dual Lip Seal System prevents entry of dust & coolant into the bearing assembly.
- Runout less than 0.005 mm (MT-5 : 0.010mm MT-6 : 0.020mm)
- POINT STYLE (NOSE STYLE) 60 Degrees

應用

- 中型細長系列為超高轉速設計，其轉速更甚於重型 R 系列
- 僅適用於中小型加工件的高速切削
- 採滾針軸承組件的設計，適用於高長徑比的加工件

特性

- 採用歐洲和日本製造的高精度三軸承設計
- 軸承的潤滑油採德國克魯勃 (Kluber Germany) 生產的 ISO Flex NBU 15
- 本體材質：20MnCr5 (相當於 SAE 8620) ，硬度 55-58 HRC。
- 尖端材質：軸承鋼 EN-31 (等同於 SAE 52100) ，硬度 60HRC
- 雙層密封系統可防止灰塵和冷卻劑進入軸承組件
- 精度小於 0.005mm (MT-5 為 0.010mm ，MT-6 為 0.015mm)
- 尖端類型為 60 度

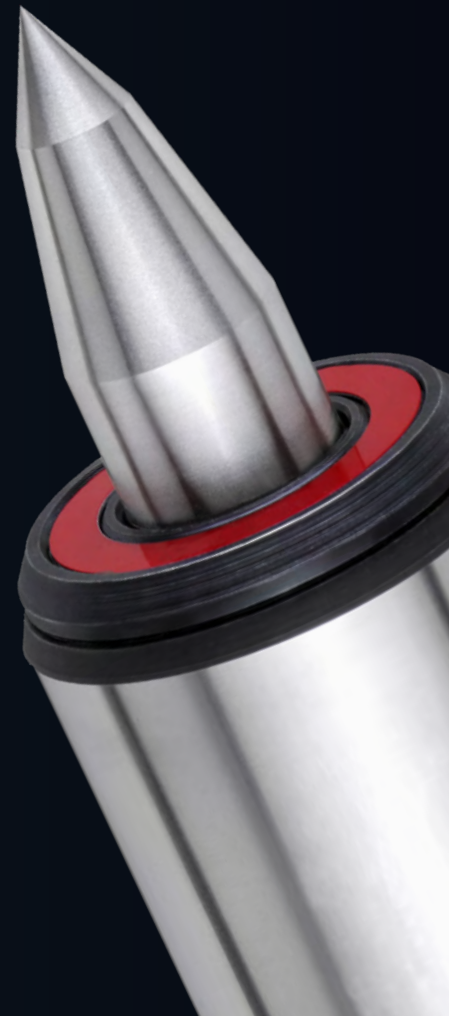

MDL-01 (STUB POINT) 中型細長系列

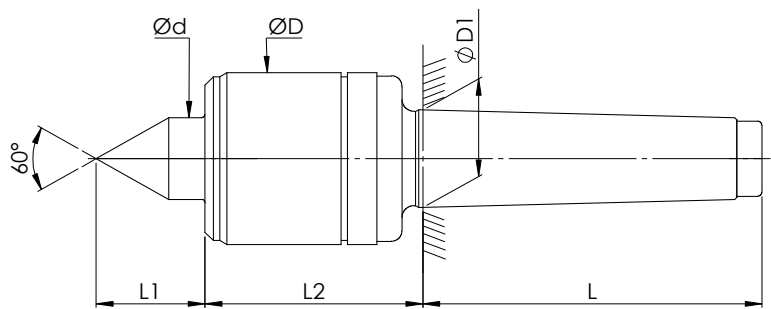

Code No. 型號	Type 規格	Shank Taper 刀柄 ØD1 mm	Ød mm	ØD mm	L1 mm	L2 mm	L mm	Max. Job Wt. Kg 加工件重量	Conc. Error mm 精度	Max. RPM 迴轉速
BTSMC120011A	MDL-01-3A	MT3(23.825)	20	42	26	52	81	450	0.005	6300
BTSMC120012A	MDL-01-4A	MT4(31.267)	24	54	32	63	102.5	800	0.005	4500
BTSMC120013A	MDL-01-5A	MT5(44.399)	38	87	51	91.5	129.5	2000	0.010	2800
BTSMC120014A	MDL-01-6A	MT6(63.348)	59.5	125	68	107.5	182	5000	0.020	1900

MDL-02 (EXTENDED POINT) 中型細長系列

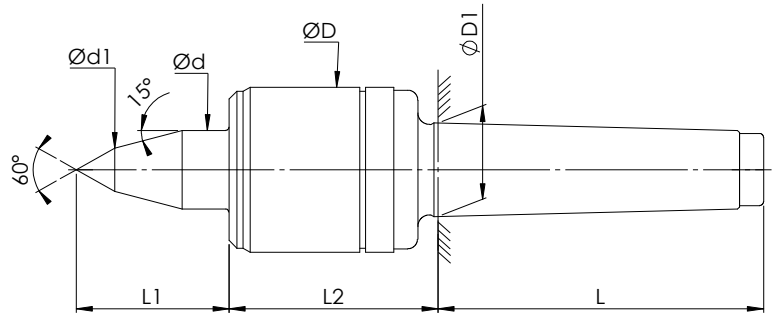

Code No. 型號	Type 規格	Shank Taper 刀柄 ØD1 mm	Ød1 mm	Ød mm	ØD mm	L1 mm	L2 mm	L mm	Max. Job Wt. Kg 加工件重量	Conc. Error mm 精度	Max. RPM 迴轉速
BTSMC120021A	HDL-02-3A	MT3(23.825)	20	11	42	38	52	81	250	0.008	5750
BTSMC120022A	HDL-02-4A	MT4(31.267)	24	13	54	44	63	102.5	375	0.008	4500
BTSMC120023A	HDL-02-5A	MT5(44.399)	38	16	87	65	91.5	129.5	900	0.010	2700
BTSMC120024A	HDL-02-6A	MT6(63.348)	59.5	22	125	100	107.5	182	2000	0.020	1750

MDL-03 (PROFILED POINT) 中型細長系列

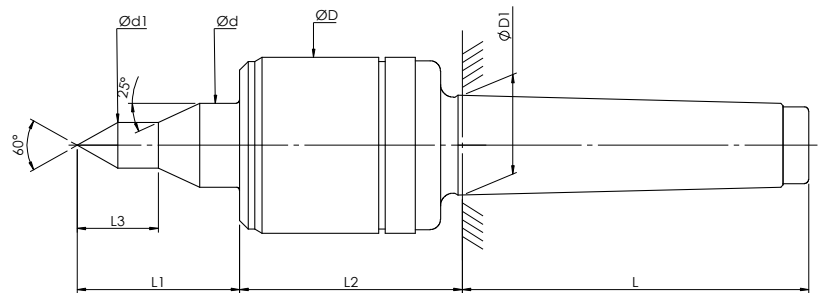

Code No. 型號	Type 規格	Shank Taper 刀柄 ØD1 mm	Ød1 mm	Ød mm	ØD mm	L1 mm	L2 mm	L mm	Max. Job Wt. Kg 加工件重量	Conc. Error mm 精度	Max. RPM 迴轉速
BTSMC120031A	MDL-03-3A	MT3(23.825)	20	11	42	38	52	81	250	0.008	5750
BTSMC120032A	MDL-03-4A	MT4(31.267)	24	13	54	44	63	102.5	375	0.008	4500
BTSMC120033A	MDL-03-5A	MT5(44.399)	38	16	87	65	91.5	129.5	900	0.010	2700
BTSMC120034A	MDL-03-6A	MT6(63.348)	59.5	22	125	100	107.5	182	2000	0.020	1750

CNC MEDIUM DUTY WITH SMALL CASING DIAMETER

中型小徑系列

APPLICATION

- CNC Medium Duty with Small Casing Diameter Model is suitable for very high rpm requirement in excess of what the CNC Heavy Duty R Model is suitable for.
- Suitable only for light & medium duty applications for very small work pieces.
- Suitable for work pieces with high L/D (length to diameter) ratio due to roller bearing assembly.

DESIGN FEATURES

- It is a triple bearing design with High Precision bearings used of European & Japanese make.
- The bearings are lubricated for life with Kluber Germany make ISO Flex NBU 15 Grease.
- Body material: 20MnCr5 (Equivalent to SAE 8620) case hardened to 55-58 HRC.
- Point Material: Bearing steel EN-31(Equivalent to SAE 52100) hardened to 60HRC.
- Good Quality Dual Lip Seal System prevents entry of dust & coolant into the bearing assembly.
- Runout less than 0.005 mm (MT-5 : 0.010mm MT-6 : 0.015mm)
- POINT STYLE (NOSE STYLE) 60 Degrees

應用

- 中型小徑系列為超高轉速設計，其轉速更甚於重型 R 系列
- 僅適用於小型加工件的輕型及中型高速切削
- 採用滾針軸承組件的設計，適用於高長徑比的加工件

特性

- 採用歐洲和日本製造的高精度三軸承設計
- 軸承的潤滑油採德國克魯勃 (Kluber Germany) 生產的 ISO Flex NBU 15
- 本體材質：20MnCr5（相當於 SAE 8620），硬度 55-58 HRC
- 尖端材質：軸承鋼 EN-31（相當於 SAE 52100），硬度 60HRC
- 雙層密封系統可防止灰塵和冷卻劑進入軸承組件
- 精度小於 0.005 毫米（MT-5 : 0.010mm MT-6 : 0.015mm）
- 尖端類型為 60 度

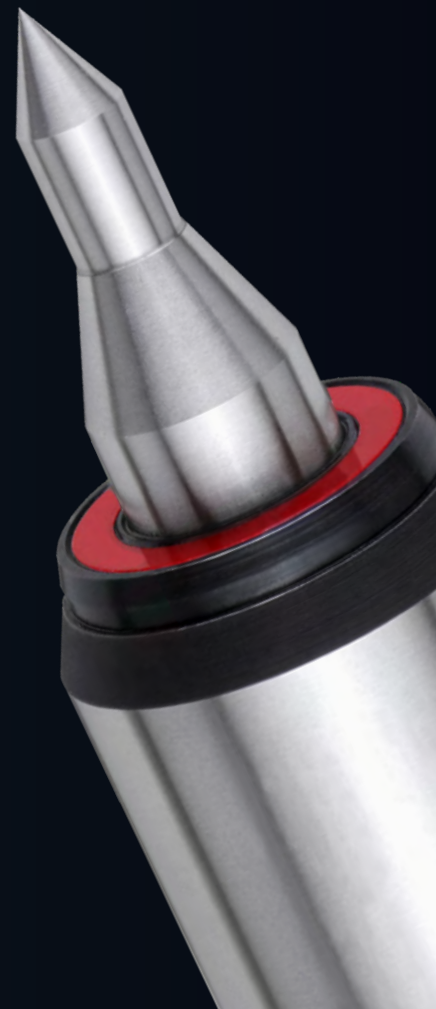

MDC-01 (STUB POINT) 中型小徑系列

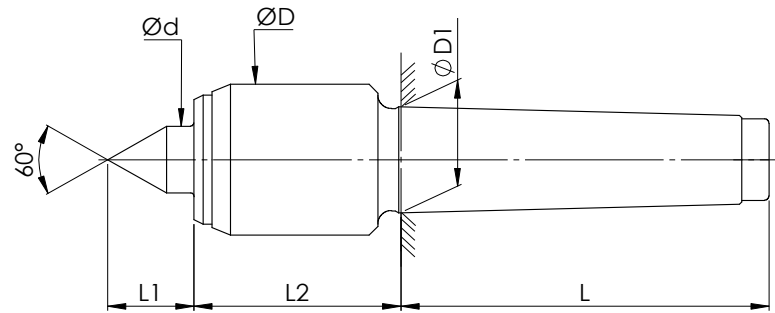

Code No. 型號	Type 規格	Shank Taper 刀柄 ØD1 mm	Ød mm	ØD mm	L1 mm	L2 mm	L mm	Max. Job Wt. Kg 加工件重量	Conc. Error mm 精度	Max. RPM 迴轉速
BTSMC130010A	MDC-01-2A	MT2(17.78)	15	34	19	45.5	64.0	200	0.005	7000
BTSMC130011A	MDC-01-3A	MT3(23.825)	15	34	19	45.5	81.0	400	0.005	7000
BTSMC130012A	MDC-01-4A	MT4(31.267)	20	42	25	53.5	102.5	800	0.005	6300
BTSMC130013A	MDC-01-5A	MT5(44.399)	32	68	41	76.5	129.5	1600	0.010	4300
BTSMC130014A	MDC-01-6A	MT6(63.348)	50	102	58	104.0	182.0	3500	0.015	3000

MDC-02 (EXTENDED POINT) 中型小徑系列

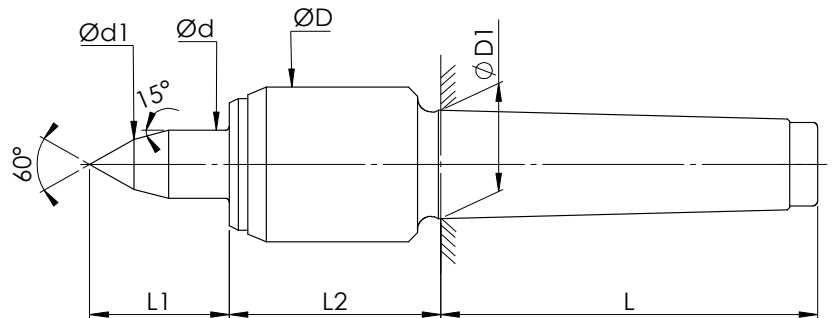

Code No. 型號	Type 規格	Shank Taper 刀柄 ØD1 mm	Ød1 mm	Ød mm	ØD mm	L1 mm	L2 mm	L mm	Max. Job Wt. Kg 加工件重量	Conc. Error mm 精度	Max. RPM 迴轉速
BTSMC130020A	MDC-02-2A	MT2(17.78)	15	10	34	29	48.5	64.0	125	0.008	6300
BTSMC130021A	MDC-02-3A	MT3(23.825)	15	11	34	30	48.5	81.0	250	0.008	6300
BTSMC130022A	MDC-02-4A	MT4(31.267)	20	13	42	38	56.0	102.5	375	0.008	5600
BTSMC130023A	MDC-02-5A	MT5(44.399)	32	14	68	53	78.0	129.5	900	0.010	3300

MDC-03 (PROFILED POINT) 中型小徑系列

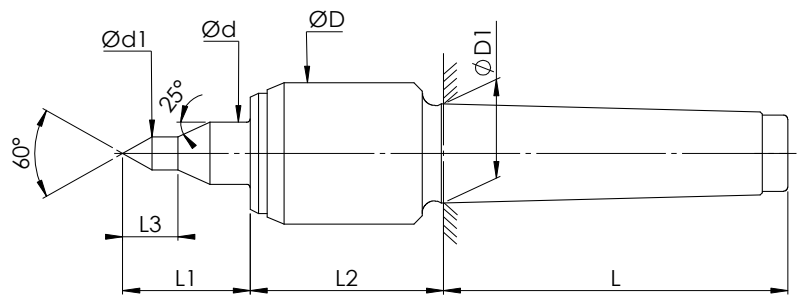

Code No. 型號	Type 規格	Shank Taper 刀柄 ØD1 mm	Ød1 mm	Ød mm	ØD mm	L1 mm	L2 mm	L3 mm	L mm	Max. Job Wt. Kg 加工件重量	Conc. Error mm 精度	Max. RPM 迴轉速
BTSMC130030A	MDC-02-2A	MT2(17.78)	15	6	34	29	48.5	12	64.0	100	0.008	6300
BTSMC130031A	MDC-02-3A	MT3(23.825)	15	8	34	30	48.5	16	81.0	200	0.008	6300
BTSMC130032A	MDC-02-4A	MT4(31.267)	20	10	42	38	56.0	20	102.5	300	0.008	5600
BTSMC130033A	MDC-02-5A	MT5(44.399)	32	14	68	53	78.0	28	129.5	800	0.010	3300

Chum Power



CHUMPOWER MACHINERY CORP.
銓寶工業股份有限公司

No.688-1, Sec. 3, Zhongshan Rd., Wuri Dist, Taichung City 414, Taiwan
414 台中市烏日區中山路三段 688-1 號

TEL: 886 4 2338 8289 | FAX: 886 4 2336 5626
Email: dali@chumpower.com