

OTT PULL STUD TYPE CLAMPING

四瓣爪 OTT PULL STUD TYPE CLAMPING

■ Design Features

- All the above materials are composed of alloy steel.
- The Gripper in accordance with the tool standard of MAS 403 system.
- Grippers are developed for integrated and comprise four clamping segments, which is suitable for high and low-speed turning spindles.
- The surfaces of Grippers are wear-resisting, anticorrosive and special tensile force treatment. The tensile force can bear 1,000 KG force which means 1 million times of lifetime testing circle in our each Grippers. (**ie.BT40)
- Easy to assemble and suitable for every type of spindles.
- Our Grippers are followed the examples of OTT standards.

■ 特點

- 四瓣爪材料皆以合金鋼製成
- 此四瓣爪依據 MAS 403 標準工具規範製作
- 一體式分隔爪片設計適用於各種高低轉速之主軸
- 爪片表面經耐磨耗、防腐蝕之特殊處理，拉力經循環壽命測試機測試可承受 1000Kg、100 萬次 (*BT40 為例)
- 採用易拆裝設計，適於各型系列主軸使用
- 同步採用德國 OTT 之說明規範



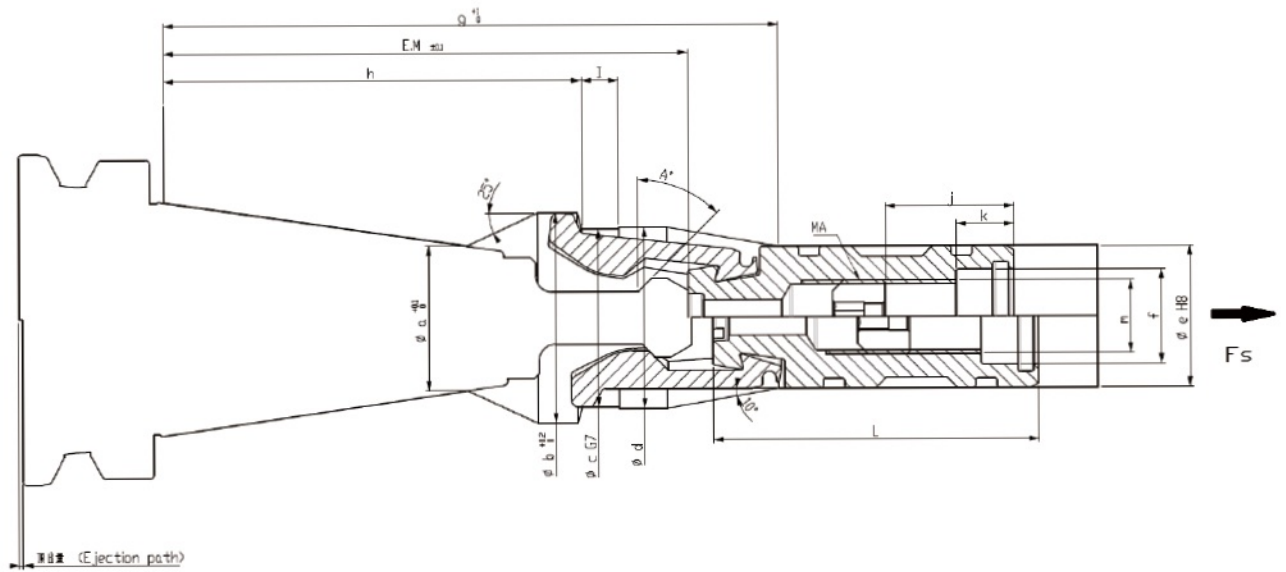

Code No. 型號	TYPE 規格	A*	a	b	c	d	e	f
BA900TTB30001A	BT30-45°	45°	19.5	27	22.5	23	19	12
BA900TTB40001A	BT40-45°	45°	27.6	40	34	34.5	27	18
BA900TTB40002A	BT40-30°	30°						
BA900TTB40003A	BT40-90°	90°						
BA900TTB50001A	BT50-45°	45°	43	56	49	49.5	40	20
BA900TTB50002A	BT50-30°	30°						
BA900TTB50003A	BT50-90°	90°						

Code No. 型號	g	h	l	j	k	L	m	Ejection path 頂出量	Fs max. (kN)	MA(Nm)
BA900TTB30001A	91	59	7	23	11	57	M10xP1.25	1	10	30
BA900TTB40001A	117	79.5	7	24.5	11	62	M14xP1.5	0.65	18	65
BA900TTB40002A										
BA900TTB40003A										
BA900TTB50001A	163	116.5	8	31.5	13	68	M16xP1.5	1	35	160
BA900TTB50002A										
BA900TTB50003A										

* Fs : 最大拉刀力 (Max.clamping Force)
 * MA : 最大鎖緊扭矩 (Max.Tightening Torque)

OTT PULL STUD TYPE CLAMPING

四瓣爪 OTT PULL STUD TYPE CLAMPING



■ Design Features

- All the above materials are composed of alloy steel.
- The Gripper in accordance with the tool standard of ANSI system.
- Grippers are developed for integrated and comprise four clamping segments, which is suitable for high and low-speed turning spindles.
- The surfaces of Grippers are wear-resisting, anticorrosive and special tensile force treatment. The tensile force can bear 1,000 KG force which means 1 million times of lifetime testing circle in our each Grippers. (**ie.CAT40)
- Easy to assemble and suitable for every type of spindles.
- Our Grippers are followed the examples of OTT standards.

■ 特點

- 四瓣爪材料皆以合金鋼製成
- 此四瓣爪依據 ANSI 標準工具規範製作
- 一體式分隔爪片設計適用於各種高低轉速之主軸
- 爪片表面經耐磨耗、防腐蝕之特殊處理，拉力經循環壽命測試機測試可承受 1000Kg、100 萬次 (*CAT40 為例)
- 採用易拆裝設計，適於各型系列主軸使用
- 同步採用德國 OTT 之說明規範

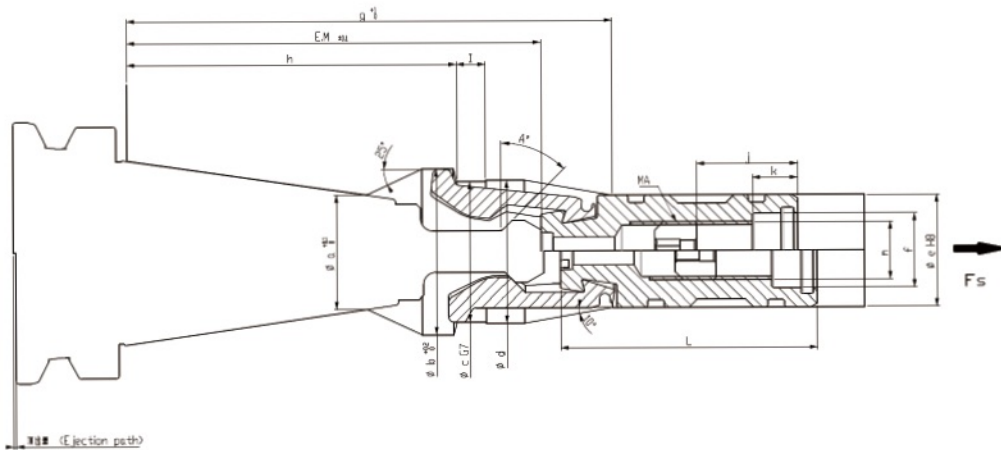

CAT

Code No. 型號	TYPE 規格	A*	a	b	c	d	e	f	g
BA900TTC40001A	CAT40	45	27.6	40	34	34.5	27	18	117
BA900TTC50001A	CAT50		43	56	49	49.5	40	20	163
Code No. 型號	h	i	j	k	L	m	Ejection path 頂出量	F _s max.(kN)	MA(Nm)
BA900TTC40001A	79.5	7	24.5	11	78	M14xP1.5	1.6	18	65
BA900TTC50001A	116.5	8	31.5	13	87	M16xP1.5	1	35	160

* F_s : 最大拉刀力 (Max.clamping Force)
 * MA : 最大鎖緊扭矩 (Max.Tightening Torque)

OTT PULL STUD TYPE CLAMPING

四瓣爪 OTT PULL STUD TYPE CLAMPING



■ Design Features

- All the above materials are composed of alloy steel.
- The Gripper in accordance with the tool standard of DIN 69871 / 69872 system.
- Grippers are developed for integrated and comprise four clamping segments, which is suitable for high and low-speed turning spindles.
- The surfaces of Grippers are wear-resisting, anticorrosive and special tensile force treatment. The tensile force can bear 1,000 KG force which means 1 million times of lifetime testing circle in our each Grippers. (**ie.DIN40)
- Easy to assemble and suitable for every type of spindles.
- Our Grippers are followed the examples of OTT standards.

■ 特點

- 四瓣爪材料皆以合金鋼製成
- 此四瓣爪依據 DIN 69871 / 69872 標準工具規範製作
- 一體式分隔爪片設計適用於各種高低轉速之主軸
- 爪片表面經耐磨耗、防腐蝕之特殊處理，拉力經循環壽命測試機測試可承受 1000Kg、100 萬次 (*DIN40 為例)
- 採用易拆裝設計，適於各型系列主軸使用
- 同步採用德國 OTT 之說明規範

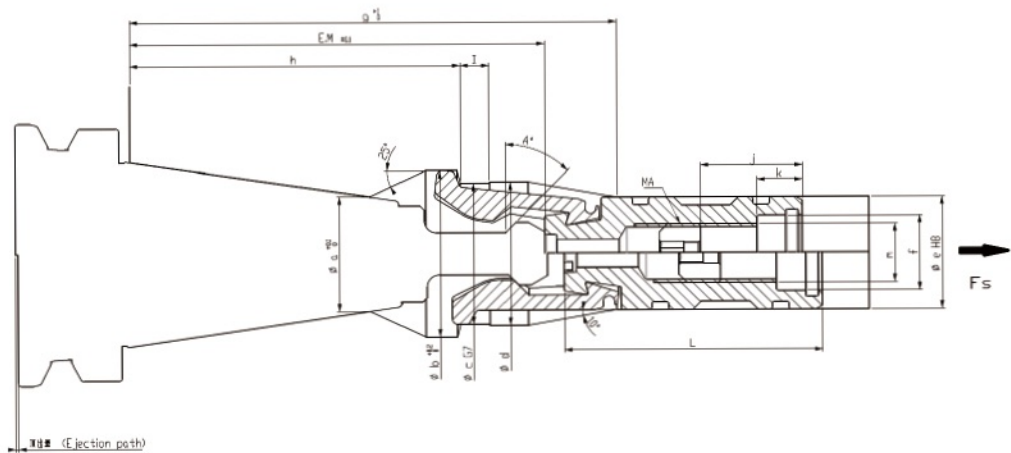

DIN

Code No. 型號	TYPE 規格	A*	a	b	c	d	e	f	g
BA900TTD40001A	DIN40	15	27.6	40	34	34.5	27	18	117
BA900TTD50001A	DIN50		43	56	49	49.5	40	20	163
Code No. 型號	h	i	j	k	L	m	Ejection path 頂出量	Fs max.(kN)	MA(Nm)
BA900TTD40001A	79.5	7	24.5	11	67	M14xP1.5	0.65	18	65
BA900TTD50001A	116.5	8	31.5	13	79.7	M16xP1.5	1	35	160

* Fs : 最大拉刀力 (Max.clamping Force)
* MA : 最大鎖緊扭矩 (Max.Tightening Torque)

OTT PULL STUD TYPE CLAMPING

四瓣爪 OTT ISO PULL STUD TYPE CLAMPING

■ Design Features

- All the above materials are composed of alloy steel.
- Suitable for high and low-speed turning spindles.
- The surfaces of Grippers are wear-resisting, anticorrosive.

■ 特點

- 四瓣爪材料皆以合金鋼製成
- 適用於各種高低轉速之主軸
- 爪片表面經耐磨耗、防腐蝕之特殊處理

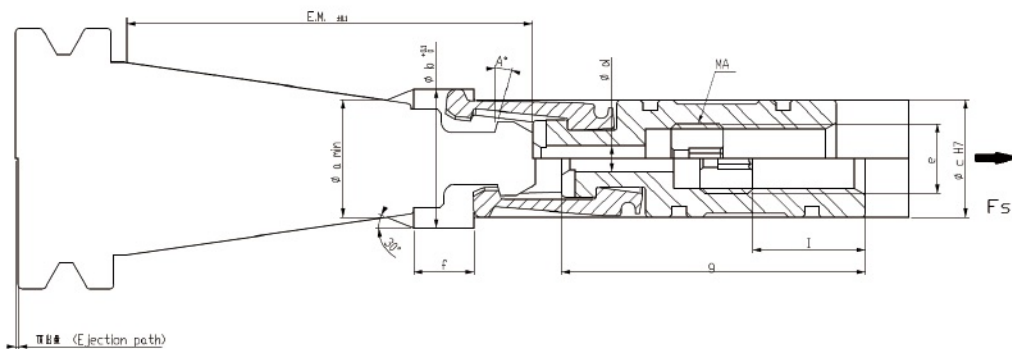

Code No. 型號	TYPE 規格	A*	a	b	c	d	e	f
BA900TTS20001A	ISO15	15°	12.5	14.5	12.5	2.5	M6xP1	5.5
BA900TTS30001A	ISO20		13.5	16	13.5	3	M8xP1.25	7
BA900TTS40002A	ISO25		14	17	14			8

Code No. 型號	g	Ejection path 頂出量	i	F _s max.(kN)	MA(Nm)
BA900TTS20001A	34	0.3	14	1.7	5
BA900TTS30001A	35	0.3	13	3	6
BA900TTS40002A	42	0.5	14	4	12

* F_s : 最大拉刀力 (Max.clamping Force)
* MA : 最大鎖緊扭矩 (Max.Tightening Torque)