

Spray Nozzle Series

Press Fit Type



FIG3



FIG2



FIG1

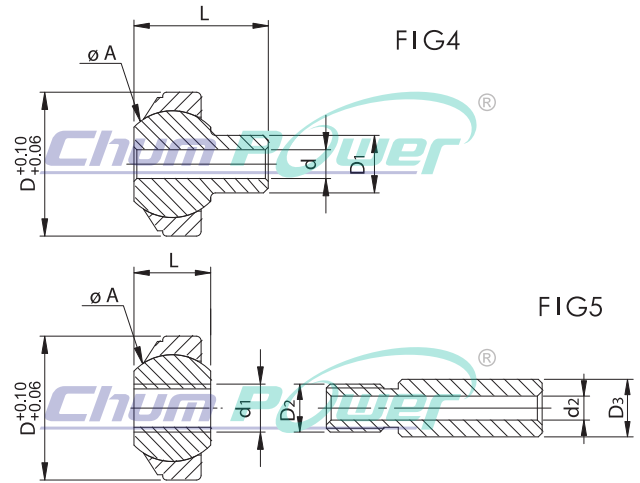

The Coolant Spray Nozzle could easily adjust its direction and spray precisely. When the coolants correspond with three pressures-low, medium and high pressures, it can precisely aim at workpiece. They are suitable for CNC Machine Center, CNC Lathes, CNC Milling Machine, Grinding Machine and so on. The products can enhance the processing efficiency and accuracy. Also it is helpful for extending the lifetime of tools and decreasing the cost.

噴水頭系列 壓配型

可任意調整噴水口角度，並有效對應低、中、高冷卻液液壓，正確噴向瞄準點。適用於綜合切削機、銑床、車床等各式工具機。此項產品除可提高加工效率及精度外，亦有助於延長工具使用壽命和減少成本消耗。

Code No. 型號	Nominal dimensions mm 規格								Ball dia 球徑	Allowable tilting angle degree 可調整角度	FIG
	D	D1	D2	D3	L	d	d1	d2	A	α	
90101	15	-	-	-	8	-	ø4	-	7/16"	29	1
90102	15	ø6	-	-	14	ø3	-	-	7/16"	29	2;4
90103	15	-	M5x0.8	ø6	8	-	M5x0.8	2.5	7/16"	29	3;5
90104	12	-	-	-	7	-	M5x0.8	-	9mm	28	1
90108	10	-	-	-	5.5	-	M4x0.7	-	7mm	23	1