

## Spray Nozzle Series Thread Mount Type

The Coolant Spray Nozzle could easily adjust its direction and spray precisely. When the coolants correspond with three pressures-low, medium and high pressures, it can improve cooling efficiency of tools. They are suitable for CNC Machine Center, CNC Lathes, CNC Milling Machine, Grinding Machine and so on. The products can enhance the processing efficiency and accuracy. Also it is helpful for extending the lifetime of tools and decreasing the cost.

### 噴水頭系列 螺紋型

可任意調整噴水口角度，並有效對應低、中、高冷卻液液壓，提昇刀具冷卻效率。適用於綜合切削機、銑床、車床等各式工具機。此項產品除可提高加工效率及精度外，亦有助於延長工具使用壽命和減少成本消耗。

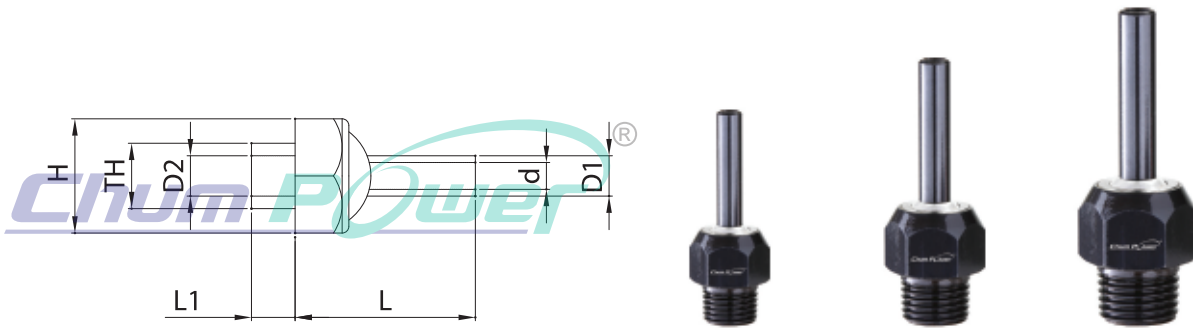

Code No. 型號	Thread mount 螺紋組接	L	L1	D1	D2	d	H
9011100	PT 1/8	20	10	6	5	4	17
9011200	PT 1/8	40					
9011000	PT 1/8	60					
9011300	PT 1/4	20	10	6	5	4	17
9011400	PT 1/4	40					
9011500	PT 1/4	60					
9011600	PT 3/8	30	13	8	10	6	24
9011700	PT 3/8	50					
9011800	PT 3/8	70					
9011900	PT 1/2	40	18	10	12	8	32
9012000	PT 1/2	60					
9012100	PT 1/2	80					
9012200	M10*1.25P	20	8	6	5	4	17
9012300	M10*1.25P	40					
9012400	M10*1.25P	60					
9012500	M20*1.5P	30	13	8	10	6	24
9012600	M20*1.5P	50					
9012700	M20*1.5P	70					
9012800	M24*2.0P	40	18	10	12	8	31
9012900	M24*2.0P	60					
9013000	M24*2.0P	80					
9013100	NPT 1/4	20	10	6	5	4	17
9013200	NPT 1/4	40					
9013300	NPT 1/4	60					
9013400	NPT 3/8	30	13	8	10	6	24
9013500	NPT 3/8	50					
9013600	NPT 3/8	70					