

# SPINDLE CLAMPING SYSTEM

## EZ-BAR

### LASER COOLANT POINTER 雷射導水筆

#### Introduction & Features

- The Laser Coolant Pointer is designed for the machines where you need to adjust the coolant Spray Nozzles of the spindle.
  - The main purpose is for the operator to correct the angle of coolant water and to prevent the operator from being sprayed by the coolant water.
- Leading by the laser coolant pointer can be adaptable for every kinds of cutting process (as Fig.1 and Fig.2 ).
- At the same time, it can improve the trouble of occupying too much space for the traditional adjustable coolant system hoses.

#### 特點:

- 雷射導水筆搭配主軸噴水頭即能簡便地校正冷卻水柱與刀具散熱點的角度。
- 雷射導水筆的導引與主軸噴水頭的配合，適用於工具機上的各種切削加工，(如圖1、圖2)並且有助於減少使用者與切削水直接接觸。
- 同時此項產品的設計亦可有效解決傳統噴水軟管占空間的困擾。

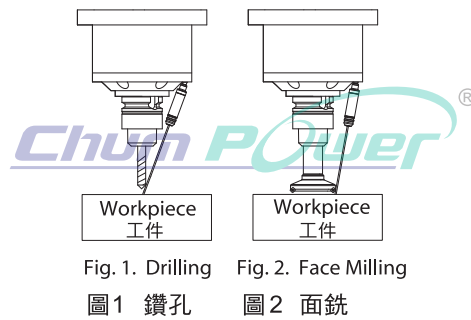

#### Name of each parts ( Fig. 3 )

1. Laser Head
2. Big O-Ring
3. Battery
4. Body
5. Small O-Ring
6. Adjust Link Stick

#### 各部位名稱(圖3)

1. 雷射頭
2. 大O型環
3. 電池
4. 本體
5. 小O型環
6. 調整接桿

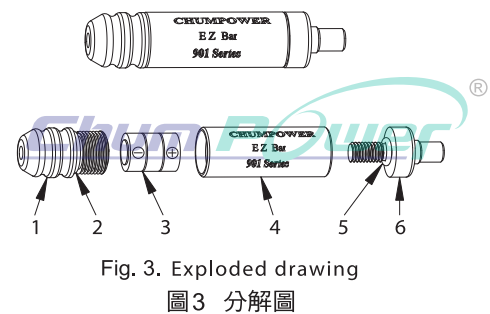

#### The Code No. & Spec. of the Adjust Link Stick (Fig.4) 調整接桿編號與規格，如下表及圖4所示

Code No.	Spec.			
	A	B	C	D
90100L				
90100L-AA	ø6mm	5mm	-	-
90100L-BB	-	-	ø4mm	7mm
90100L-CC	-	-	ø5mm	7mm
90100L-DD	-	-	ø6mm	7mm

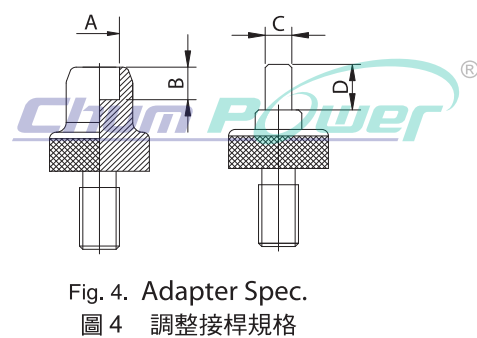

# EZ-BAR

#### Installations & Attentions

※ Please confirm the following steps before installing :

- Please confirm the neck of Laser Head & Adjust Link Stick shall wear the Big O-Ring & Small O-Ring to avoid infiltrating the water.
- The negative of battery shall be headed forward the Laser Head.
- The inner of the Body shall insert the plastic cushion to avoid the results of short circuit in the negative of battery & Body.

※ Installation :

- After you confirmed as above, you can assemble the all parts according to Fig.3.

#### 安裝步驟與注意事項

安裝前請確認.....

- 為避免滲水，請確認雷射頭與調整接桿之頸部套有大O型環及小O型環。
- 電池負極需朝向雷射頭。
- 本體內部嵌入塑膠墊片，用以避免電池負極與本體造成短路。

安裝.....

- 確認工作完畢後，依照圖3爆炸圖順序裝入即可。



#### Attentions on Usage & Maintenance

- When the Adjust Link Stick is screwed in the Body completely, the Laser Collation Bar is under the condition of "ON".
- After correcting the position of the Fountain Outlet, please screw out the Adjust Link Stick slightly. It'll avoid the unnecessary consumption for electric power.
- To check the cleanness of the lens of Laser Head as regular. If it is dirty, you can wipe it with the cotton bud.
- To check the O-Ring as regular, if it keeps the elasticity and without transfiguration to avoid infiltrating the water.
- You may not aim to your eyes by 650nm Diode Laser. Otherwise, it'll hurt your retina.

#### 使用與保養注意事項

- 當調整接桿完全旋入本體時，雷射導水筆處於開啓的狀態。
- 噴水口角度位置校正結束後，請將調整接桿略為旋出，避免電量消耗。
- 定期檢查雷射頭鏡面之清潔，骯髒時可使用棉花棒進行擦拭。
- 定期檢查O型環是否保持彈性及變形，以避免滲水。
- 不可將紅外線二極體雷射對準眼睛，以避免傷害到視網膜。