

- ▶ Quick Change Tap Collets with Overload Clutch
- ▶ DIN 371 Type

Features:

• Overload Clutch is designed to prevent tap from breaking upon tapping.

- ▶ 快換式絲攻夾頭-扭力型
- ▶ DIN 371

特性:

• 扭力型絲攻設計，可預防絲攻在攻牙時斷裂。

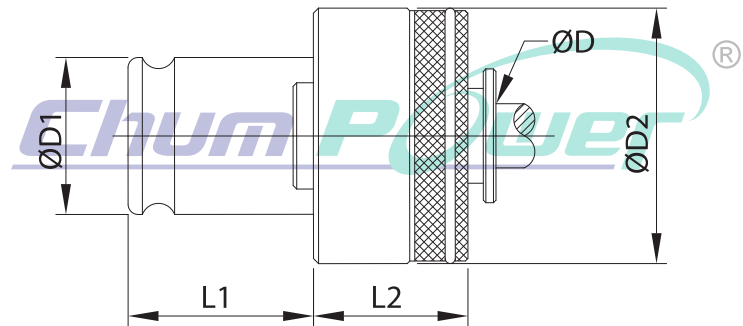

Code NO. 型號	TC312 DIN371 Tap	Tap Shank 絲攻尺寸		Capacity 攻牙能力	L1 (mm)	L2 (mm)	ØD1 (mm)	ØD2 (mm)
		ØD柄徑	□四方孔					
35223	M1~M1.8	2.5	2.1	M 3~M14	22	25	19	32
35224	M 2~M2.5	2.8	2.1					
35225	M 3	3.5	2.7					
35226	M3.5	4.0	3.0					
35227	M 4	4.5	3.4					
35228	M4.5	6.0	4.9					
35229	M 5	6.0	4.9					
35230	M 6	6.0	4.9					
35231	M 8	8.0	6.2					
35232	M10	10.0	8.0					

Code NO. 型號	TC820 DIN371 Tap	Tap Shank 絲攻尺寸		Capacity 攻牙能力	L1 (mm)	L2 (mm)	ØD1 (mm)	ØD2 (mm)
		ØD柄徑	□四方孔					
35130	M 5	6.0	4.9	M 8~M24	36	30.5	31	50
35131	M 6	6.0	4.9					
35132	M 8	8.0	6.2					
35133	M10	10.0	8.0					

*Custom-Built products are available on request. *特製品可依客戶需求訂製