

- ▶ Quick Change Tap Collets _Rigid Type ▶ 快換式絲攻_ 剛性
- ▶ DIN 371 ▶ DIN 371

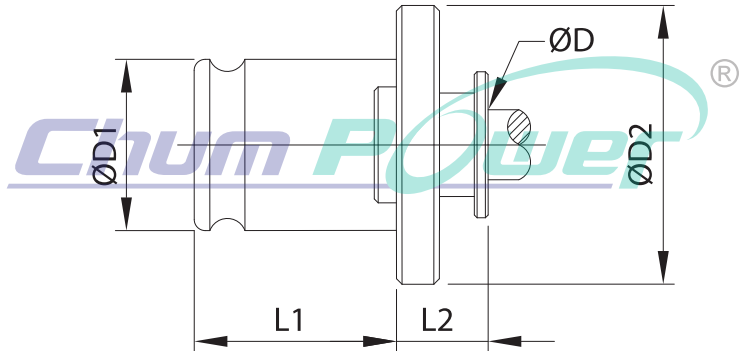

Code NO. 型號	TC 308B DIN371 TAP	Tap Shank 絲攻尺寸		Capacity 攻牙能力	L1 (mm)	L2 (mm)	øD1 (mm)	øD2 (mm)
		øD	□					
35824	M 1~M1.8	2.5	2.1	M 3~M 8	19.5	7	12.65	22
35825	M 2~M2.5	2.8	2.1					
35826	M 3	3.5	2.7					
35827	M3.5	4.0	3.0					
35828	M 4	4.5	3.4					
35829	M4.5	6.0	4.9					
35830	M 5	6.0	4.9					
35831	M 6	6.0	4.9					
35832	M 8	8.0	6.2					

Code NO. 型號	TC312B DIN371 TAP	Tap Shank 絲攻尺寸		Capacity 攻牙能力	L1 (mm)	L2 (mm)	øD1 (mm)	øD2 (mm)
		øD	□					
35423	M 1~M1.8	2.5	2.1	M 3~M14	22	7	19	30
35424	M 2~M2.5	2.8	2.1					
35425	M 3	3.5	2.7					
35426	M3.5	4.0	3.0					
35427	M 4	4.5	3.4					
35428	M4.5	6.0	4.9					
35429	M 5	6.0	4.9					
35430	M 6	6.0	4.9					
35431	M 8	8.0	6.2					
35432	M10	10.0	8.0					

Code NO. 型號	TC820B DIN371 TAP	Tap Shank 絲攻尺寸		Capacity 攻牙能力	L1 (mm)	L2 (mm)	øD1 (mm)	øD2 (mm)
		øD	□					
35529	M4.5	6.0	4.9	M 8~M24	36	11	31	48
35530	M 5	6.0	4.9					
35531	M 6	6.0	4.9					
35532	M 8	8.0	6.2					
35533	M10	10.0	8.0					

*Custom-Built products are available on request. *特製品可依客戶需求訂製