

- ▷ Quick Change Tap Collets - Rigid Type
- ▷ 快換式絲攻 - 剛性
- ▷ ISO 529/2283
- ▷ ISO 529/2283

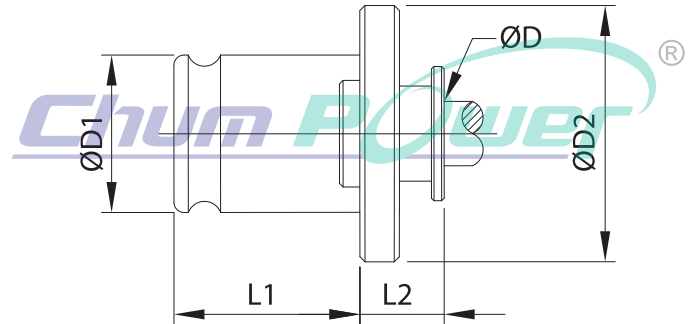

Code NO. 型號	TC312B ISO 529/ 2283 Tap	Tap Shank 絲攻尺寸		Capacity 攻牙能力	L1 (m/m)	L2 (m/m)	øD1 (m/m)	øD2 (m/m)
		øD柄徑	四方孔					
35475	M 3	2.24	1.8	M 3~M14	22	7	19	30
35476	M3.5	2.5	2.0					
35477	M 4	3.15	2.5					
35478	M4.5	3.55	2.8					
35479	M 5	4.0	3.15					
35480	M 6	4.5	3.55					
35481	M 7	5.6	4.5					
35482	M 8	6.3	5.0					
35483	M 9	7.1	5.6					
35484	M10	8.0	6.3					
35485	M12	9.0	7.1					
35486	M14	11.2	9.0					
Code NO. 型號	TC820B ISO 529/ 2283 Tap	Tap Shank 絲攻尺寸		Capacity 攻牙能力	L1 (m/m)	L2 (m/m)	øD1 (m/m)	øD2 (m/m)
		øD柄徑	四方孔					
35556	M 8	6.3	5.0	M 8~M24	36	11	31	48
35558	M 9	7.1	5.6					
35560	M10	8.0	6.3					
35562	M12	9.0	7.1					
35564	M14	11.2	9.0					
35566	M16	12.5	10.0					
35568	M18	14.0	11.2					
35570	M20	14.0	11.2					
35572	M22	16.0	12.5					
35574	M24	18.0	14.0					
Code NO. 型號	TC1433B ISO 529/ 2283 Tap	Tap Shank 絲攻尺寸		Capacity 攻牙能力	L1 (m/m)	L2 (m/m)	øD1 (m/m)	øD2 (m/m)
		øD柄徑	四方孔					
35656	M14	11.2	9.0	M14~M36	56	14	48	70
35658	M16	12.5	10.0					
35660	M18	14.0	11.2					
35662	M20	14.0	11.2					
35664	M22	16.0	12.5					
35666	M24	18.0	14.0					
35668	M27	20.0	16.0					
35670	M30	20.0	16.0					
35672	M33	22.4	18.0					
35674	M36	25.0	20.0					

\*Custom-Built products are available on request. \*特製品可依客戶需求訂製