

▷ **Universal Tap Chuck**

▷ **Morse Taper Shank**

Application:

The products are suitable for CNC Machining Centers, CNC Turning Centers, High-Speed Center Lathes, Drilling Machines, Radial Drilling Machines, Air Tapping Machines, Milling Machines and other machines with reversible spindles.

▷ 泛用型剛性夾頭

▷ 莫氏錐度型

用途:

此產品適用於CNC中心加工機, 高速車床, 直立式鑽床, 銑床及其它可反轉的主軸。

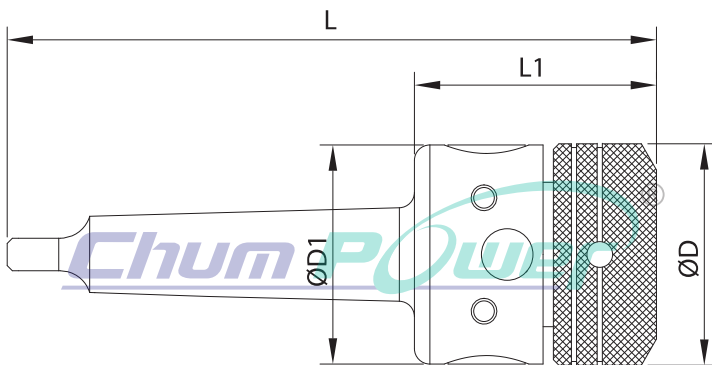

Code NO. 型號	Size 尺寸	Capacity 攻牙能力		Taper Mount NO. DIN or Jacobs 錐孔組接型號	L (mm)	L1 (mm)	øD (mm)	øD1 (mm)	Weight(g) 重量
		mm	inch						
35015	1/2"	M3~M12	1/8"~1/2"	MT2	129	49	43	42.5	
35017	1/2"	M3~M12	1/8"~1/2"	MT3	148	49	43	42.5	
35051	5/8"	M3~M16	1/8"~5/8"	MT2	136	60	48.5	46	732
35052	5/8"	M3~M16	1/8"~5/8"	MT3		60	48.5	46	
35031	3/4"	M9~M18	3/8"~3/4"	MT2	143.5	58	51	49	924
35033	3/4"	M9~M18	3/8"~3/4"	MT3	162.5	58	51	49	1074
35035	3/4"	M9~M18	3/8"~3/4"	MT4	187.5	58	51	49	1380

*Custom-Built products are available on request. *特製品可依客戶需求訂製