

HSK SIDE LOCK END MILL HOLDER

HSK 側固式立銑刀把

HSK Shank DIN 69893-1A with Side Lock End Mill DIN 1835B

APPLICATION:

- It can be applied for heavy cutting and milling process generally. ■ 適用於重切削及一般銑削加工
- The cutting tools can be clamped precisely. Even it's worked in heavy cutting, it will not result in slipping on cutting tools. ■ 刀具夾持確實，即使重切削亦不致造成刀具滑動
- The product matches HSK BBT system (Big+Plus). It can increase the stability on the side direction processing. ■ 搭配HSK兩面拘束，可增加側向加工的穩定性。

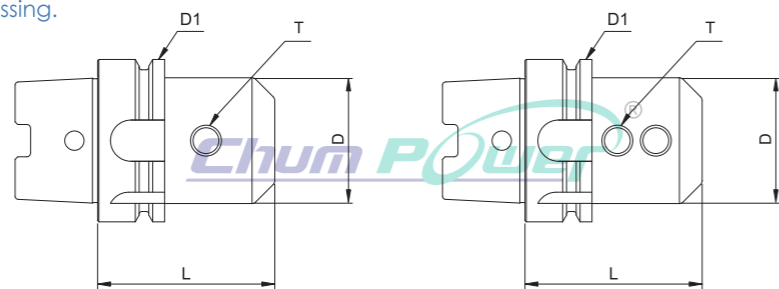

FIG. 1

FIG. 2

Code NO. 型號	TYPE 規格	L	D	D1	T	FIG. 圖
HK04015	HSK50AxSLN6- 65	65	25	50	M6	1
HK04025	HSK50AxSLN8- 65	65	28	50	M8	1
HK04035	HSK50AxSLN10- 65	65	35	50	M10	1
HK04045	HSK50AxSLN12- 80	80	42	50	M12	1
HK04050	HSK50AxSLN14- 80	80	44	50	M12	1
HK04055	HSK50AxSLN16- 80	80	48	50	M14	1
HK04065	HSK50AxSLN18- 80	80	50	50	M14	1
HK04070	HSK50AxSLN20- 80	80	52	50	M16	1

HK04080	HSK63AxSLN6- 65	65	25	63	M6	1
HK04090	HSK63AxSLN8- 65	65	28	63	M8	1
HK04100	HSK63AxSLN10- 65	65	35	63	M10	1
HK04110	HSK63AxSLN12- 80	80	42	63	M12	1
HK04115	HSK63AxSLN14- 80	80	44	63	M12	1
HK04120	HSK63AxSLN16- 80	80	48	63	M14	1
HK04130	HSK63AxSLN18- 80	80	50	63	M14	1
HK04145	HSK63AxSLN25- 110	110	65	63	M18	2
HK04150	HSK63AxSLN32- 110	110	72	63	M20	2

HK04155	HSK100AxSLN6- 80	80	25	100	M6	1
HK04160	HSK100AxSLN8- 80	80	28	100	M8	1
HK04165	HSK100AxSLN10- 80	80	35	100	M10	1
HK04170	HSK100AxSLN12- 80	80	42	100	M12	1
HK04175	HSK100AxSLN14- 80	80	44	100	M12	1
HK04180	HSK100AxSLN16- 100	100	48	100	M14	1
HK04185	HSK100AxSLN18- 100	100	50	100	M14	1
HK04190	HSK100AxSLN20- 100	100	52	100	M16	1
HK04195	HSK100AxSLN25- 100	100	65	100	M18	2
HK04200	HSK100AxSLN32- 100	100	72	100	M20	2
HK04205	HSK100AxSLN40- 120	120	90	100	M20	2

*Custom-built products are available on request.

HSK SIDE LOCK END MILL HOLDER

HSK 側固式立銑刀把

HSK Shank DIN 69893-1A with Side Lock End Mill DIN 1835E

APPLICATION:

- It can be applied for heavy cutting and milling process generally. ■ 適用於重切削及一般銑削加工
- The cutting tools can be clamped precisely. Even it's worked in heavy cutting, it will not result in slipping on cutting tools. ■ 刀具夾持確實，即使重切削亦不致造成刀具滑動
- The product matches HSK BBT system (Big+Plus). It can increase the stability on the side direction processing. ■ 搭配HSK兩面拘束，可增加側向加工的穩定性。

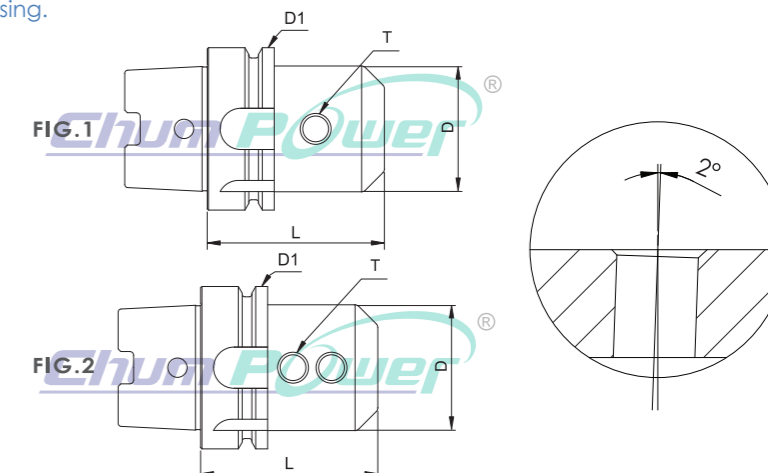

FIG. 1

FIG. 2

Code NO. 型號	TYPE 規格	L	D	D1	T	FIG. 圖
HK04210	HSK50AxSLNB6- 80	80	25	50	M6	1
HK04215	HSK50AxSLNB8- 80	80	28	50	M8	1
HK04220	HSK50AxSLNB10- 80	80	35	50	M10	1
HK04225	HSK50AxSLNB12- 90	90	42	50	M12	1
HK04230	HSK50AxSLNB14- 90	90	44	50	M12	1
HK04235	HSK50AxSLNB16- 90	90	48	50	M14	1
HK04240	HSK50AxSLNB18- 90	90	50	50	M14	1
HK04245	HSK50AxSLNB20- 100	100	52	50	M16	1

HK04250	HSK63AxSLNB6- 80	80	25	63	M6	1
HK04255	HSK63AxSLNB8- 80	80	28	63	M8	1
HK04260	HSK63AxSLNB10- 80	80	35	63	M10	1
HK04265	HSK63AxSLNB12- 90	90	42	63	M12	1
HK04270	HSK63AxSLNB14- 90	90	44	63	M12	1
HK04275	HSK63AxSLNB16- 100	100	48	63	M14	1
HK04280	HSK63AxSLNB18- 100	100	50	63	M14	1
HK04285	HSK63AxSLNB20- 100	100	52	63	M16	1
HK04290	HSK63AxSLNB25- 110	110	65	63	M18	2
HK04295	HSK63AxSLNB32- 110	110	72	63	M20	2

HK04300	HSK100AxSLNB6- 90	90	25	100	M6	1
HK04305	HSK100AxSLNB8- 90	90	28	100	M8	1
HK04310	HSK100AxSLNB10- 90	90	35	100	M10	1
HK04315	HSK100AxSLNB12- 100	100	42	100	M12	1
HK04320	HSK100AxSLNB14- 100	100	44	100	M12	1
HK04325	HSK100AxSLNB16- 100	100	48	100	M14	1
HK04330	HSK100AxSLNB18- 100	100	50	100	M14	1
HK04335	HSK100AxSLNB20- 110	110	52	100	M16	1
HK04340	HSK100AxSLNB25- 120	120	65	100	M18	2
HK04345	HSK100AxSLNB32- 120	120	72	100	M20	2
HK04350	HSK100AxSLNB40- 120	120	90	100	M20	2

*Custom-built products are available on request.