

## SK MILLING CHUCK

### SK 強力式立銑刀把

SK Shank DIN 69871-A

#### FEATURES:

- It is designed with inner rolling needles inside. This design can reduce the friction resistance when tightening and the wear of parts.
- The design of dustproof can prevent iron scrap dropping and extend longevity of chuck.
- The high clamping force is available. The product can prevent the cutting tools from slipping when the users worked it and increase the longevity of cutting tools.
- High rigidity
- High precision

#### 特 性

- 內部滾針設計，可減少鎖緊時之摩擦阻力及零件磨耗。
- 防塵設計減少鐵屑掉入以延長使用壽命。
- 高夾持力，防止刀具於加工時滑脫，增加刀具壽命
- 高剛性
- 高精度

#### APPLICATION:

- The Milling chuck can be applied for heavy-duty & higher accuracy cutting.
- 此強力銑刀把適用重型及高精密切削

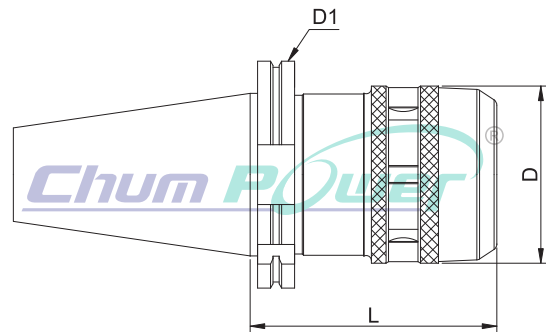

Code NO. 型號	TYPE 規格	L	D	D1	Spanner No. 扳手編號
SK03005	SK30xC20- 85	85	52	50	80200-05
SK03015	SK40xC20- 85	85	52	63.55	80200-05
SK03030	SK40xC32- 105	105	69		80200-15
SK03040	SK50xC20- 105	105	52	97.5	80200-05
SK03050	SK50xC32- 110	110	69		80200-15
SK03060	SK50xC42- 110	110	86		80200-20

\*Custom-built products are available on request.

