

BT CHU CNC DRILL CHUCK

BT 直結式鑽夾頭

BT Shank JIS B 6339(MAS 403 BT)

APPLICATION:

- The product can be adapted for the general lathe or the drilling processing whose machines center can supply with BT spindle.
- 適用於傳統銑床或其他提供BT主軸介面之工作母機作鑽孔加工。

FEATURES:

- 3 times better clamping capacity, comparing to keyed drill chucks.
- The drill bit won't be loosen or falling off.
- Twice precision than the keyed drill chucks.
- The drill chuck is interchangeable.
- 比普通夾頭多3倍的夾持力
- 鑽頭不會鬆脫或掉落
- 比普通夾頭多出2倍精準
- 可替換式的夾頭

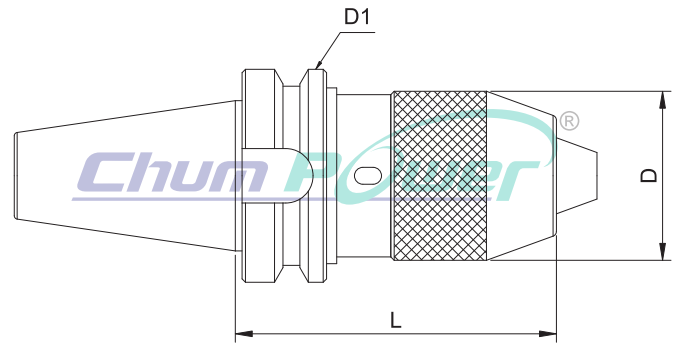

Code NO. 型號	TYPE 規格	L	D	D1	Spanner No. 扳手編號
BT01505	BT30xCHU8- 75	75	37	46	12802
BT01510	BT30xCHU13- 90	90	50		12806
BT01515	BT40xCHU8- 85	85	37	63	12802
BT01525	BT40xCHU13-95	95	50		12806
BT01545	BT40xCHU16-120	120	57		12808
BT01550	BT50xCHU13- 110	110	50	100	12806
BT01564	BT50xCHU16-110	110	57		12808

*Custom-built products are available on request.