

BT MILLING CHUCKS

BT 強力式立銑刀把

BT Shank JIS B 6339(MAS 403 BT)

FEATURES:

- It is designed with inner rolling needles inside. This design can reduce the friction resistance when tightening and the wear of parts.
- The design of dustproof can prevent iron scrap dropping and extend longevity of chuck.
- The high clamping force is available. The product can prevent the cutting tools from slipping when the users worked it and increase the longevity of cutting tools.
- High rigidity
- High precision

特 性

- 內部滾針設計，可減少鎖緊時之摩擦阻力及零件磨耗。
- 防塵設計減少鐵屑掉入以延長使用壽命。
- 高夾持力，防止刀具於加工時滑脫，增加刀具壽命
- 高剛性
- 高精密

APPLICATION:

- The Milling chuck can be applied for heavy-duty & higher accuracy cutting.
- 此強力銑刀把適用重型及高精密切削

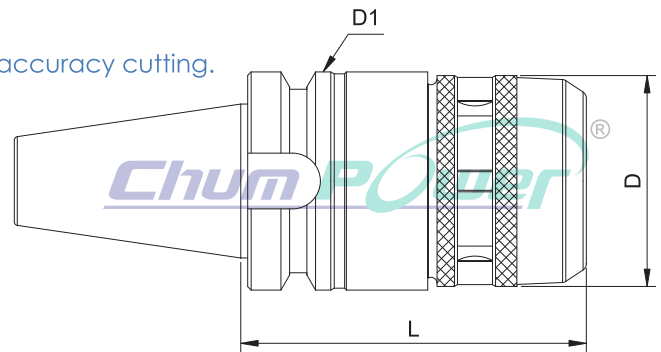

Code NO. 型號	TYPE 規格	L	D	D1	Spanner No. 扳手編號
BT03005	BT30xC20- 80	80	52	46	80200-05
BT03015	BT30xC25- 85	85	60		80200-10
BT03020	BT40xC20- 85	85	52	63	80200-05
BT03025	BT40xC20- 100	100			
BT03030	BT40xC20- 135	135			
BT03035	BT40xC25- 90	90	60		80200-10
BT03040	BT40xC25- 135	135			
BT03055	BT40xC32- 105	105	69		80200-15
BT03065	BT40xC32- 135	135			
BT03070	BT50xC20- 105	105	52	100	80200-05
BT03075	BT50xC20- 150	150			
BT03080	BT50xC25- 100	100			
BT03085	BT50xC25- 150	150	60		80200-10
BT03095	BT50xC32- 110	110			
BT03100	BT50xC32- 135	135	69		80200-15
BT03125	BT50xC42- 110	110			
BT03130	BT50xC42- 135	135	86		80200-20

*Custom-built products are available on request.

