

## Z Axial Preset Gauge

Z軸設定器

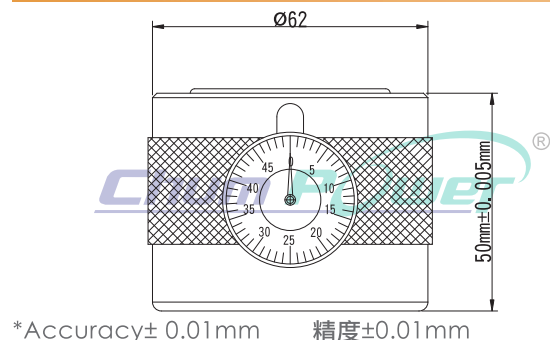

\*Accuracy ± 0.01mm 精度 ± 0.01mm

Code NO. 型號	TYPE 規格
80553	ø50-50



## Z Axial Preset Gauge

Z軸設定器

- For setting length on machining centers/lathe centers.
- Setting height: 50.00±0.005mm.
- Large measuring surface and easy to operate.
- Low spring force, May avoid the milling cutter or the drill bit breaking.
- Easy to be calibrated by a ground parallel or gauge block.
- Better parallelism, sensitivit, and precision for use.
- 在電腦銑床/車床上設定刀長用
- 設計高度：50.00±0.005mm
- 量側面大，操作容易
- 彈簧力較小，可避免小銑刀或鑽頭斷裂
- 用研磨過的平行板，即可簡單設定
- 平行度及各方面使用靈敏，且精度更好



Code NO. 型號	TYPE 規格	Height 高度 (mm)	G.W.Weight 重量(KGS)	LxWxH 長X寬X高 (mm)	Magnetism 磁性
84551	ZH-50A	50.00±0.005	1.2	50x63x63	○

## Tool Holder Locking Device

鎖刀座

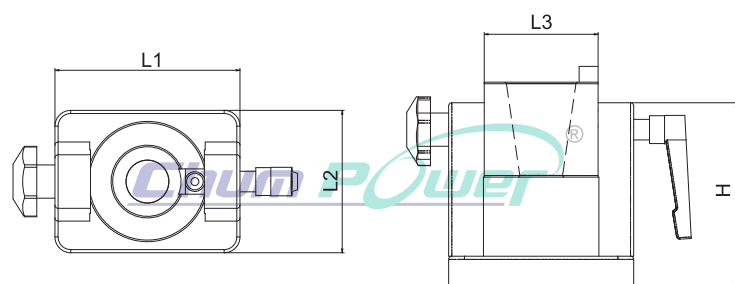

Code NO. 型號	TYPE 規格	L1	L2	L3	H
84523	BT/ CAT/ SK30	117	90	72	117
84524	BT/ CAT/ SK40	117	90	72	117
84525	BT/ CAT/ SK50	137	90	92	130

## Tool Locking Device

鎖刀座

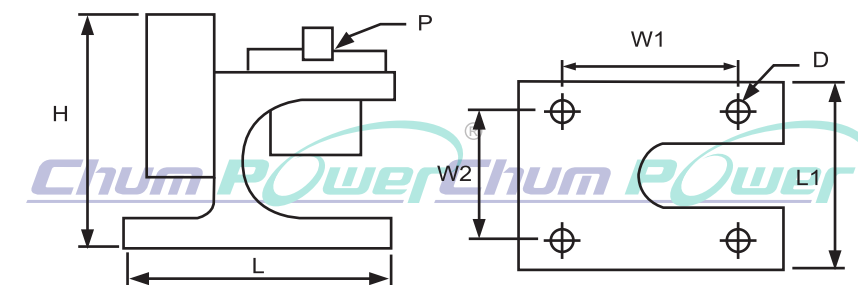

Code NO. 型號	TYPE 規格	P	L	L1	H	W1	W2	D	Weight 重量 (kg)
84510	BT30	BT	145	103	143	112	72	13	4.2
84511	BT40	BT	145	103	143	112	72	13	4.2
84512	BT50	BT	177	135	205	140	100	13	7.6
84516	CAT30	CAT	145	103	143	112	72	13	4.2
84517	CAT40	CAT	145	103	143	112	72	13	4.2
84518	CAT50	CAT	177	135	205	140	100	13	7.6

## Tool Locking Device A Type (Cast Iron Body)

鎖刀座 A型 (主體為鑄鐵)

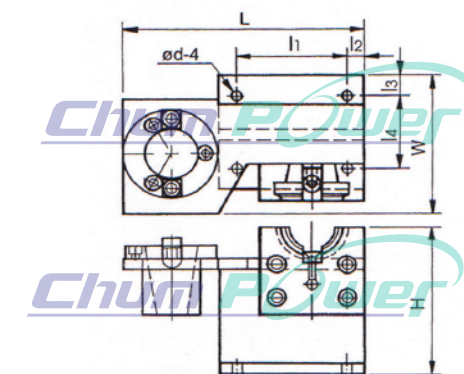

Code NO. 型號	TYPE 規格	L	l1	l2	l3	l4	H	W	N.W. 淨重(kg)	G.W. 毛重(kg)	Shipment Size 裝箱尺寸 (cm)
8451001	CP-BT30A	210	95	10	15	67	130	100	3.6	3.7	22x11.5x14
8451101	CP-BT40A	210	95	10	15	67	130	100	3.7	3.9	22x11.5x14
8451201	CP-BT50A	275	113	20	24	105	200	150	11.0	11.4	29.5x17x21
8452901	CP-DIN40A	210	95	10	15	67	130	100	3.6	3.8	22x11.5x14
8453001	CP-DIN50A	275	113	20	24	105	200	150	10.8	11.2	29.5x17x21
8451701	CP-CAT40A	210	95	10	15	67	130	100	3.6	3.8	22x11.5x14
8451801	CP-CAT50A	275	113	20	24	105	200	150	10.8	11.2	29.5x17x21